

SOFIPLUS TUTORIAL

Copyright SOFiSTiK AG, D-81514 München, 1990-2002

This documentation is protected by copyright. No part of it may be reproduced, translated or rewritten in any way without prior written permission by SOFiSTiK AG. SOFiSTiK reserves the right to revise this publication or amend its content at any time.

SOFiSTiK declares that it has produced the documentation and the program according to the best of its knowledge, but undertakes no warranty that the documentation or programs are free of errors. Errors or inadequacies will in general be eliminated, as they became known.

Users remain responsible for their own applications. The user shall perform random spot checks to check the accuracy of the calculation performed by the software.

Trademarks

Windows, Windows 95/98 and Windows NT are registered trademarks of Microsoft.

AutoCAD is registered trademarks of Autodesk, Inc.

SOFiSTiK and SlabDesigner are registered trademarks of SOFiSTiK AG in Munich.

Table of Content:

1. BASIC	1—7
1.1 WORKING DIRECTORY	1—7
1.2 DRAWING NAME	1—8
1.3 LAYERS.....	1—8
1.4 AUTOMATIC SAVING.....	1—8
1.5 BASIC ANALYSIS STEPS.....	1—8
1.6 STRUCTURAL SYSTEM.....	1—9
1.7 MATERIAL.....	1—14
1.8 CROSS SECTION.....	1—15
1.9 CREATE FINITE ELEMENTS	1—17
1.10 SUPPORTS.....	1—19
1.11 INFO / EDIT.....	1—21
1.12 SUPPORT VISUALIZATION	1—23
1.13 LOADS.....	1—25
1.14 LOAD MODIFICATION.....	1—31
1.15 MODIFICATION OF NODE LOADS.....	1—31
1.16 MODIFICATION OF ELEMENT LOADS	1—32
1.17 DATABASE EXPORT.....	1—32
1.18 ANALYSIS	1—35
2. WORKING WITH THE ANIMATOR	2-38
3. WORKING WITH WINGRAF	3-43
4. EXAMPLE 1 : STEEL HALL	4-64
4.1 HALL DESCRIPTION.....	4-64
4.2 AUTOCAD PREPARATIONS	4-64
4.3 STRUCTURAL SYSTEM.....	4-65
4.4 MATERIAL.....	4-66
4.4.1.....	4-66
4.5 CROSS SECTIONS.....	4-67
4.6 ORIENTATION OF ELEMENTS.....	4-75
4.7 BEAM ORIENTATION CONTROL	4-77
4.8 RESTRAINTS	4-79
4.9 VISUALIZATION OF THE RESTRAINTS.....	4-80
4.10 LOADING.....	4-80
4.10.1 <i>Dead load</i>	4-81
4.10.2 <i>Snow load</i>	4-82
4.10.3 <i>Wind load</i>	4-83
4.11 TRANSFERRING DATA INTO DATABASE.....	4-84
4.12 STRUCTURAL ANALYSIS	4-84
4.13 TOOL.....	4-86
4.14 EXPLANATION.....	4-86
4.14.1 <i>+PROG AQUA</i>	4-87
4.14.2 <i>ECHO - Extent of Output</i>	4-88
4.14.3 <i>+ PROG GRAF</i>	4-89
4.14.4 <i>PROG STAR2 -</i>	4-91
4.14.5 <i>ECHO - Control of the Output Extent</i>	4-95
4.14.6 <i>+PROG GRAF</i>	4-95
4.14.7 <i>BEAM -Beam Element Results</i>	4-95
5. EXAMPLE 2 : ADMINISTRATIVE BUILDING	5-99
5.1 BASEMENT:	5-99
5.2 STRUCTURAL SYSTEM.....	5-99
5.3 MATERIAL.....	5-100

5.4	STRUCTURAL LINES	5-101
5.5	STRUCTURE AREAS	5-103
5.6	LOADS AND AREAS DIALOGUE BOX	5-105
5.7	SUPPORTS	5-112
5.7.1	<i>Info/Edit and Modify Structure Edge</i>	5-112
5.8	FINITE ELEMENT MESH	5-117
5.8.1	<i>Maximum possible length of element's edge</i>	5-118
5.8.2	<i>Number of relaxation steps</i>	5-118
5.8.3	<i>Output</i>	5-118
5.8.4	<i>Page numbers</i>	5-118
5.8.5	<i>Activate</i>	5-118
5.8.6	<i>Band Width Optimization</i>	5-118
5.9	STRUCTURE CONTROL	5-119
5.10	IMPORT ANALYSIS DATABASE	5-120
5.11	ANALYSIS	5-121
5.12	GRAPHICAL PRESENTATION OF RESULTS	5-123
5.13	VIEW AND PRINT RESULTS	5-126
6.	EXAMPLE 3 : PLATFORM II	6-138
6.1	AUTOCAD PREPARATION	6-138
6.2	CREATION OF FINITE ELEMENT MESH	6-142
6.3	CREATING FINITE ELEMENT MESH USING MACROS	6-143
6.4	CORRECTIONS IN FINAL ELEMENT MESH	6-146
6.5	CONSTRAINTS	6-149
6.6	BOUNDARY ELEMENTS	6-151
6.7	BEAM ELEMENTS	6-152
6.8	MODIFYNG THICKNESS OF AREA ELEMENTS	6-153
6.9	LOADING	6-154
6.10	EXPORTING DATABASE	6-158
6.11	ANIMATOR	6-159
6.12	STUCTURE ANALYSIS	6-161
7.	EXAMPLE 4 :ROOF STRUCTURE.....	7-164
7.1	AUTOCAD PREPARATION	7-164
7.2	STRUCTURAL SYSTEM	7-166
7.3	MATERIAL	7-167
7.4	CROSS SECTIONS	7-167
7.5	FINITE ELEMENT MESH	7-169
7.6	FINITE ELEMENT MODIFICATIONS	7-169
7.7	EDGE BEAMS	7-170
7.8	COLUMNS	7-171
7.9	LOADING	7-173
8.	SPACE ANALYSIS OF THE BUILDING	8-177
8.1	STRUCTURAL SYSTEM	8-178
8.2	MATERIAL	8-179
8.3	STRUCTURAL LINES	8-179
8.4	STRUCTURAL AREAS	8-180
8.5	OPENINGS	8-183
8.6	BEAMS/COLUMNS	8-184
8.7	BOUNDARY CONDITIONS	8-185
8.8	FINITE ELEMENT MESH (FEM)	8-186
8.9	DATABASE IMPORT	8-187
8.10	STRUCTURE CONTROL	8-188
8.11	CORRECTION OF THE FINITE ELEMENT MESH	8-189
8.12	BASEMENT PLATFORM	8-190
8.13	STRUCTURAL AREAS	8-191

8.14	OPENINGS	8-191
8.15	BEAMS/COLUMNS	8-192
8.16	PERMANENT PLATFORMS	8-193
8.17	FINITE ELEMENT MESH (FEM)	8-193
8.18	3D STRUCTURE	8-194
8.19	EXPORTING DATABASE	8-194
8.20	ANALYSIS OF STRUCTURE	8-195
9.	SPACE TRUSS - DOME	9-196
9.1	AUTOCAD DRAWING PREPARATION	9-196
9.2	STRUCTURAL SYSTEM	9-198
9.3	MATERIAL	9-199
9.4	CROSS SECTIONS	9-199
9.5	FINITE ELEMENT MESH	9-200
9.6	CORRECTION OF FINITE ELEMENT MESH	9-202
9.7	SUPPORTS	9-205
9.8	MODIFICATION OF SHELL ELEMENTS	9-207
9.9	INFORMATION / MODIFICATION OF STRUCTURAL ELEMENTS	9-210
9.10	LOADING	9-210
9.10.1	<i>Dead Load</i>	9-211
9.10.2	<i>Wind 1</i>	9-211
9.10.3	<i>Load 2</i>	9-212
9.10.4	<i>Snow</i>	9-212
9.10.5	<i>Installation</i>	9-213
9.10.6	<i>Temperature</i>	9-214
9.11	DATABASE EXPORT	9-214
9.12	STRUCTURE ANALYSIS	9-215
9.13	DISPLAYING NODE/ELEMENT	9-218
9.14	LOAD CONTROL	9-219
9.15	RESULTS	9-221
9.16	VISUAL CONTROL ON THE STRUCTURE AND RESULTS	9-222
9.17	QUAD ELEMENT LOADING EXAMPLES	9-225
9.17.1	<i>ELEMENT LOADS</i>	9-225
9.17.2	<i>Uniformly distributed load in local Z-axis direction</i>	9-225
9.17.3	<i>Variable load in local Z-axis direction</i>	9-226
9.17.4	<i>Uniformly distributed load in global X-axis direction - projection</i>	9-226
9.17.5	<i>Variable load in global X-axis direction - element projection</i>	9-227
9.17.6	<i>Uniformly distributed load in global X-axis direction</i>	9-227
9.17.7	<i>Variable load in global X-axis direction</i>	9-227
9.17.8	<i>In global X-axis direction</i>	9-228
9.18	SHELL ELEMENTS	9-234
9.18.1	<i>VERTICAL LOADING PLANE</i>	9-234
9.18.2	<i>Load in gravity direction</i>	9-235
9.18.3	<i>Load in global X-axis direction</i>	9-236
9.18.4	<i>Trapezoidal load in global X-axis direction</i>	9-237
9.18.5	<i>INCLINED LOADING PLANE</i>	9-238
10.	EXAMPLE 5 : LOAD DISTRIBUTION ON BUILDING	10—240

1. BASIC

The core of the SOFiSTiK program is a very efficient data base (CDBASE). The Group of programs is able to solve different problems from structural analysis to interchange data through the data base.

SOFiSTiK consists of a large number of modules which communicate with each other either through standard text files or through graphical interfaces. CADINP is a powerful command language. It allows full operation of the possibilities of certain modules in the analysis. Experienced programmers use flexible CADINP macros to simplify the data input, especially when entering complex systems.

SOFiPLUS is a graphic preprocessor which is used to create the structure. With its help, AutoCAD drawings and DXF files are converted into structural elements. The program is based on AutoCAD. The contours of the structure is drawn with the AutoCAD commands. A great number of functions easily permit to convert the basic AutoCAD entities in structural elements and loads. As a preprocessor, SOFiPLUS creates the input file, which is later used by the adequate SOFiSTiK modules for structural analysis. Therefore SOFiPLUS is the right product for any user, who wants to use the functionality of the SOFiSTiK analysis programs in conjunction with AutoCAD.

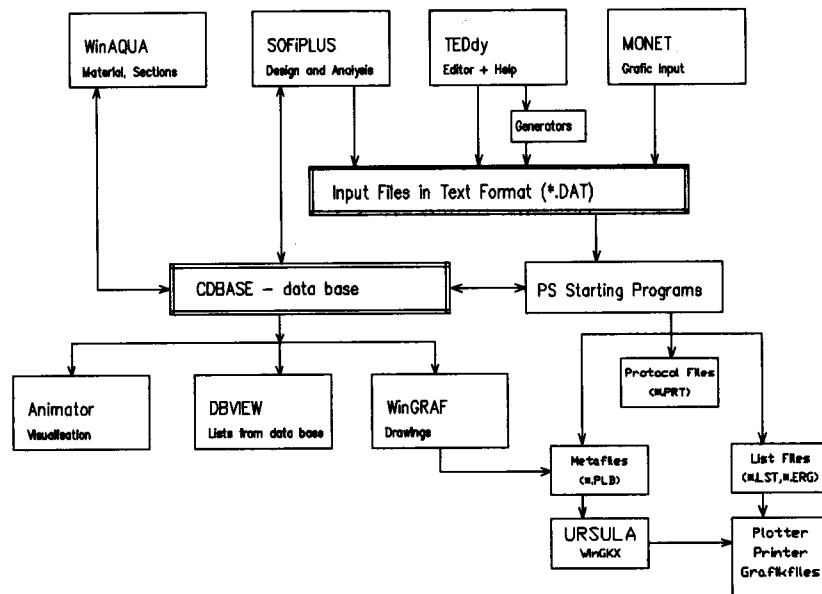

Pic. 1 SOFiSTiK Organization chart

1.1 WORKING DIRECTORY

For practical purposes it is recommended to save any data from a project in one working directory. It is eligible to create a directory with the same name as the project name. The user should create such a folder before drawing the first drawing. This directory will then contain the necessary drawings and data for the analysis of the structure.

1.2 DRAWING NAME

The drawing name should contain the necessary information to identify the drawing without having to view it. The project number, position or index may be used as recognized attributes from the drawing file name.

Example: 8901A105a.dwg

project number	
A	name of structure to be analyzed
a	index "a"
.dwg	file extension (AutoCAD file)

1.3 LAYERS

Objects created with SOFiSTiK have properties: **layer, color and line type**. Layers are construction plans on which objects are systematically grouped with different drawing information. Some layers are created during the work with SOFiPLUS. For example the program SOFiPLUS puts any nodes on the layer X__KNOT_database name. User can control visibility and access for object modifications placed on a layer. It is advisable when drawing the structure, to pay attention in grouping the construction elements on different layers. This is a particular practice for complex structures when structural elements from different types overlap. Systematical grouping allows easier object selection or their conversion into structural elements.

1.4 AUTOMATIC SAVING

Creation and analysis may take some time. It is advisable to pre-select the time interval for automatic data save. If for any reason the operating system or AutoCAD crashes, only the changes in drawings and database after the last saving interval are lost. The AutoCAD command *Preferences* allows you to adjust the time interval for automatic data save. The automatic save is made to the file name defined in *AutoCAD* → *Preferences*. If continuing working with the automatically saved file is desired, this file must be renamed.

1.5 BASIC ANALYSIS STEPS

- Create working directory
- Start AutoCAD
- Open existing drawing ("Open" command) or start the work with new drawing ("New" command) and select "Metric" for units.
- Define structural system. Make a connection between structural system and database.
- Use AutoCAD commands to draw geometry of the structure.
- Define materials used in the structure. Materials are automatically saved into database.
- Create cross sections for the structural elements. Cross sections are automatically saved into database.
- Use SOFiPLUS commands "Generate elements" or "Modify elements" to convert graphical entities in structural elements.

Define the element and node loads.
Export the structure and loads into the database. ("Export" command)
Start the analysis.
Display the results on the screen or print them in numerical or graphical form.

1.6 STRUCTURAL SYSTEM

The structural system may be created for a small part or for the whole mathematical model of the structure. For example, our usual practice is to examine three dimensional frame systems as separate two dimensional frames. In such approximation, every plane frame represents a specific structural system, which is modeled and analyzed independently. On the other hand, SOFiSTiK - with its efficient tools for modeling and analyzing - allows more realistic structure representation, treating it as three dimensional frame structure.

Structural system... allows inputting database and connecting it to the structural model. During analysis, the database remains open. Several data (materials and cross sections) are entered directly into the database, while the rest data must be explicitly exported into the database.

Coordinate system and standards for the analysis are defined only once and cannot be modified later. At the system selection, some predefined (default) materials are automatically entered into the database. Those materials can be modified with simple commands in the next analysis steps.

Important: If you make changes in the structural model with commands which are not in the SOFiPLUS pull down menu or with usual AutoCAD commands, re-exportation of the database must be performed in order to introduce the changes into the analysis.

After the command *Structural system...* a dialogue box pops up which connects project to the database.

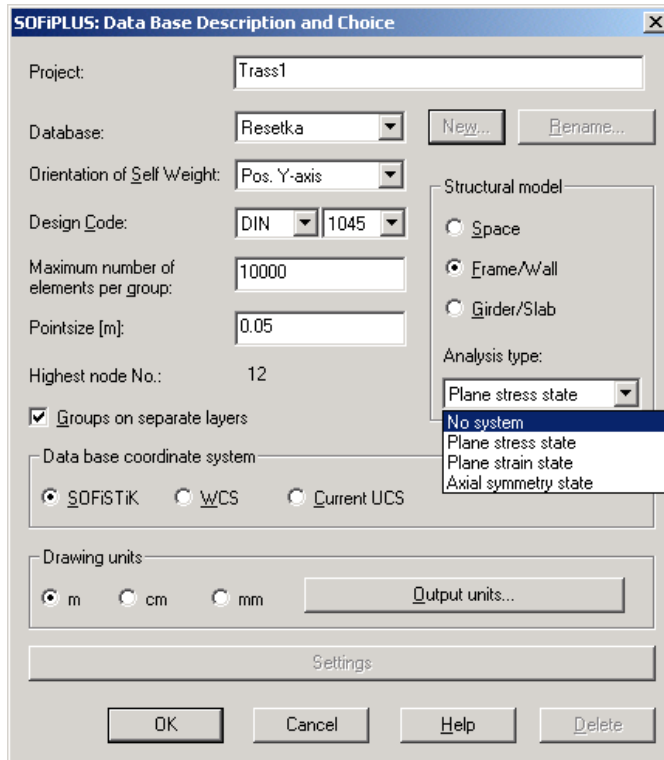

Project: Header line. All results have the same name as project name in the header line.

Database: Database name. Maximum 24 characters. Extension name .CDB is assigned automatically. Default name is drawing file name.

Orientation of Self Weight:

Orientation of the self weight.

Design Code: Choose a standard for the analysis.

Ephemeral embedded standards in SOFiSTiK are:

ACI	American
BS	British
DIN	German
EC	Euro codes
OENorm	Austrian
SIA	Swiss

Maximum elements of numbers per group:

For easier parameter control for dimensioning, elements must be divided in groups. By this input, the maximum element number is determined which may belong to a group. This value has no influence on the maximal area elements number. Elements from a structural area belong to one group.

Point size: This control determines the size of the displayed nodes and points in the structure. The text in the structural areas and holes as well as scaling the line types depends

on the entered value in *Point size*. Practically, this control determines the legibility of the drawing on the screen.

Highest node No.:

Shows the biggest number created by the program.

Groups on separate layers:

If you select this option, every group of elements is placed into separate layers.

Structural model:

Choose a structural model. Three options are available:

Space;
Frame/Wall;
Girder/Slab.

Analysis type:

For plane problems four subsystems are defined:
frame system (No system), Plane stress state, Plane strain state) and Axial symmetry state.

Data base coordinate system:

Choose one from the three suggested coordinate systems:
SOFiSTiK, *World* and *UCS*. *SOFiSTiK* coordinate system differs from AutoCAD *World* coordinate system in the direction of Z-axis. In *World* coordinate system Z-axis is directed towards users eye (right hand rule) while *SOFiSTiK* Z-axis has inverse direction.

Drawing units:

Select drawing units.

Output units:

Determine output units which will be used at dimensioning.

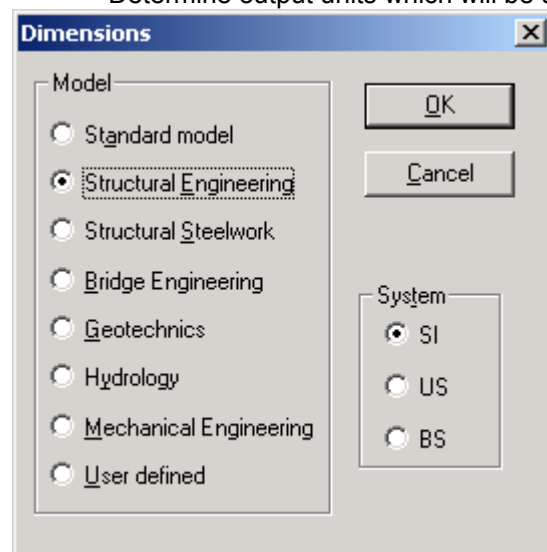

Settings: New dialogue window opens to set basic SOFiPLUS parameters.

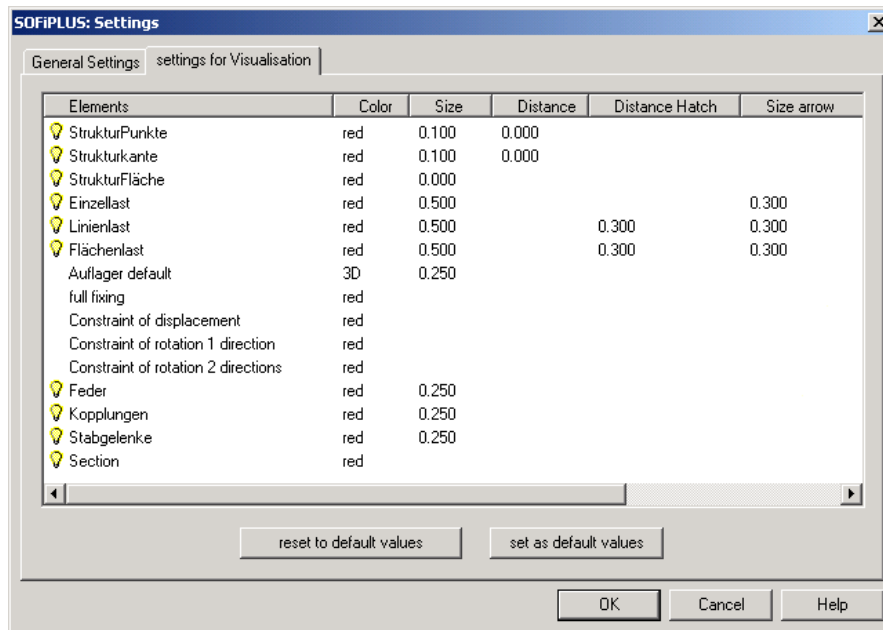

Example 1: Triangular truss with following geometry:

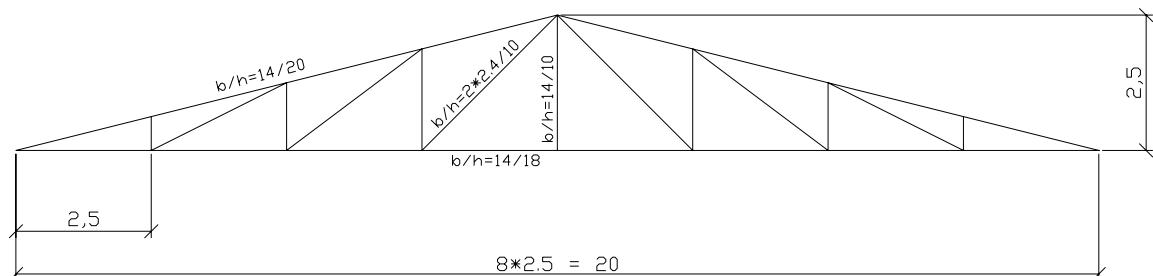

Material: Wood

Truss distance: 2.5 m

Loads:

1. Double layers of waterproof paper over wood planks 400 N/m^2
2. Snow on horizontal surface 750 N/m^2
3. Wind perpendicular to inclined surface 240 N/m^2

First, create working directory RESETKA to input the database, drawing and all additional files produced in the analysis. Draw truss geometry in AutoCAD. If you draw dimensions for the truss and additional texts it is advisable to place them in separate layers. To increase the visibility turn off all unnecessary layers from the view area. Define the database and connect it with the structural system.



ICON : SOFiPLUS
 MENU: SOFiPLUS→Structural system...
 Command: SOF_GSYSMOD

Fill / select working parameters according to enclosed picture:

Project	Resetka
Database	1521R101
Orientation of Self Weight:	Pos. Y axis
Design Code	EC
Max. num. of elem. per group	1000
Point size	0.05
Structural model	Frame/Wall
Group on separate layer	√
Data base coordinate system	SOFiSTiK
Drawing units	m

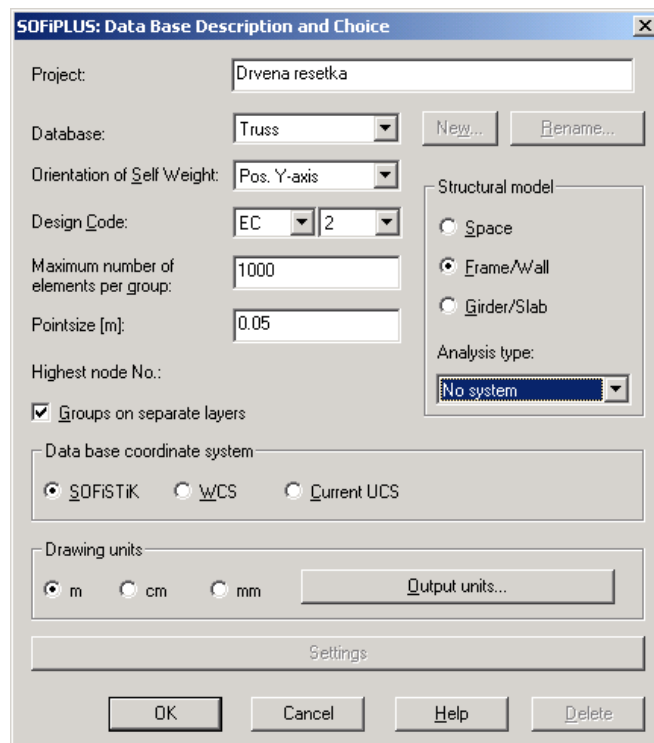

1.7 MATERIAL



ICON : Material

MENU: SOFiPLUS→Defined model→Material

Command: SOF_GSYMATE

Dialogue box displays on the screen with several default materials.

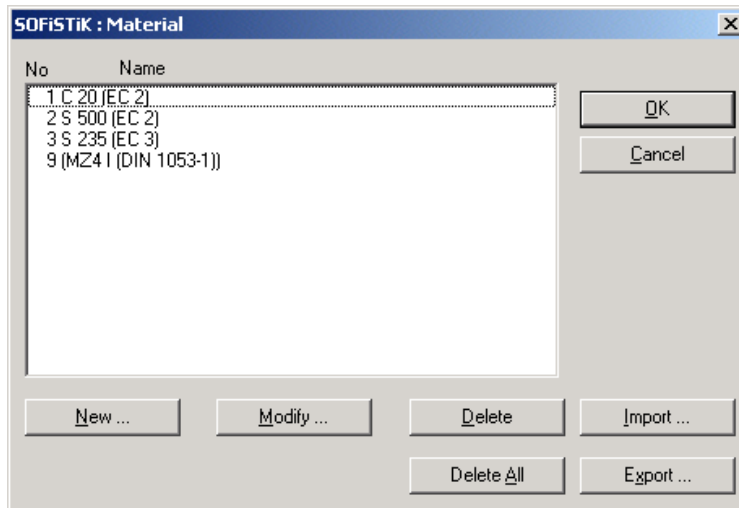

Delete or *Modify* unnecessary materials shown in the list. In this example default materials are: concrete (C20), standard reinforcement (S 235), prestressed reinforcement (S 500) and masonry (MZ4I). Delete any materials (first select the material to delete and click on *Delete* button). Because *Wood* is not in the list, it should be imported in the list by clicking on the *New* button. New dialogue box pops up on the screen.

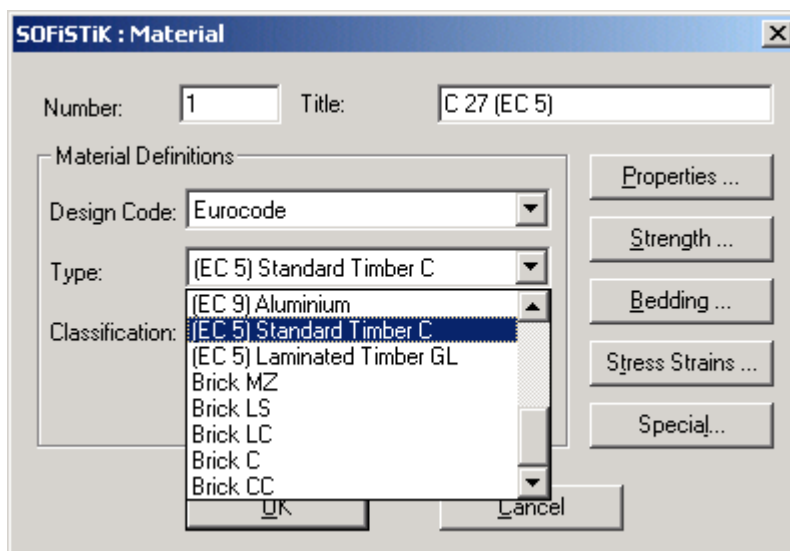

Select *(EC 5)* from the *Type* list for Standard Timber C. The described procedure is common to select standard materials, defined in implemented standards in SOFiSTiK. Review and modification of specific selected materials can be accomplished with the buttons shown on the right of the dialogue box. With this buttons nonstandard materials can be added i.e. materials which are used in standards not implemented in SOFiSTiK.

The modification procedure of the material is almost the same as the procedure for adding new material. First you should select the material and then click on the *Modify* button. The same dialogue box appears where you should select proper material and classification.

1.8 CROSS SECTION

Before creating the structural model it is desirable to define any cross sections which are used in the model. As far as changes in the following analysis steps are necessary, you can define cross sections afterwards.



ICON : Cross Section
 MENU: SOFiPLUS→Defined model→Cross Section
 Command: SOF_GQUER

By activating this command, dialogue box *Cross Section* appears.

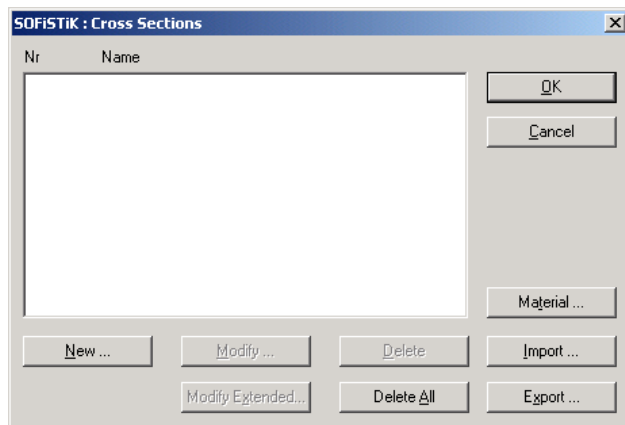

In the beginning the list is empty. You can add new cross section with the *New* button. SOFiSTiK allows simple creation of standard sections implied in national codes of many countries.

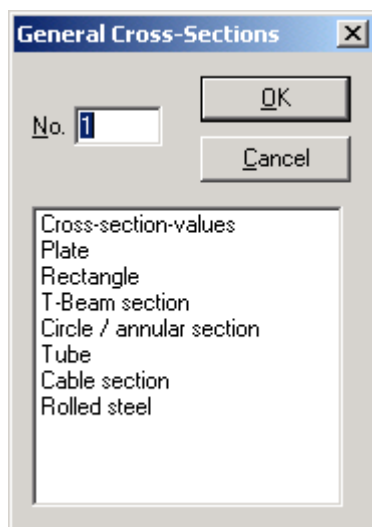

You can select one from the eight offered standard sections.

Cross-section-value. Direct input of section geometric properties

Plate-Reinforced concrete slabs

Rectangle-Rectangular cross sections

T-Beam section

Circle / annular section

Cable section

Rolled steel

In this example any element has a rectangular section. Select *Rectangle* from the list and dialogue box pops up to enter cross section values.

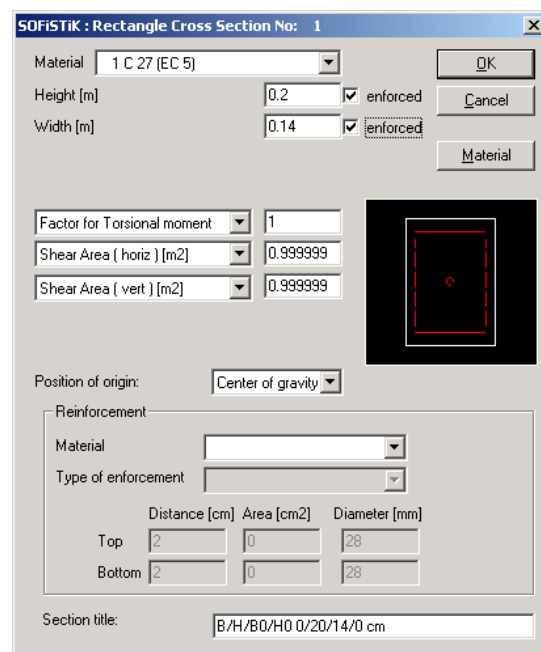

SOFISTIK : Rectangle Cross Section No: 1

Material: 1 C 27 (EC 5) [OK] [Cancel] [Material]

Height [m]: 0.2 [enforced]

Width [m]: 0.14 [enforced]

Factor for Torsional moment: 1

Shear Area (horiz) [m2]: 0.999999

Shear Area (vert) [m2]: 0.999999

Position of origin: Center of gravity

Reinforcement

Material: []

Type of enforcement: []

	Distance [cm]	Area [cm2]	Diameter [mm]
Top	2	0	28
Bottom	2	0	28

Section title: B/H/B0/H0 0/20/14/0 cm

Material: If a project consists of several materials, select the material for the examined cross section.

Height [m]: Enter section height in meters.

Width [m] : Enter section width in meters.

Following *combo boxes* allow entering torsion moment of inertia, effective shear width in vertical and horizontal direction i.e. proper reduction factors which are applied for appropriate geometric properties. In this example, axial stressed structure is examined, so these values have no influence in the analysis.

Position of origin: *Combo box* which determines section coordinate system which is used to place the section in the structure.

Reinforcement: Visual tools used to input necessary parameters for the reinforcement. In this example, they are not active because the structure is made from timber.

Section title: Name of the section. SOFiSTiK declares default name for the section. In the name height and width is contained. User can change section name and rename it to a title which is easily recognized in the following analysis steps.

Following the procedure described for section 1, enter values for the rest cross sections.

Section	H	B
---------	---	---

1	0.20	0.14
2	0.18	0.14
3	0.10	0.14
4	0.10	4.8=2*2.4

1.9 CREATE FINITE ELEMENTS

SOFiSTiK is a very flexible program. Often, several approaches are offered to model the structure. You should select the right one depending on the situation and adjust it according to your work style. At this point you have access to a large number of AutoCAD functions, which allow full control over visibility, positioning, selection, copying and modification of objects in the structure.

In this example, in the truss only one element type is used - truss finite element. Two methods for creation of truss elements are presented.

First method is activated by:



ICON : Truss element
 MENU: SOFiPLUS→Create finite element→Truss element
 Command: SOF_GFACH

Successive input of element start point (NA) and end point (NB) starts. It is possible to pick a point directly from the screen (use AutoCAD tools for precise positioning)

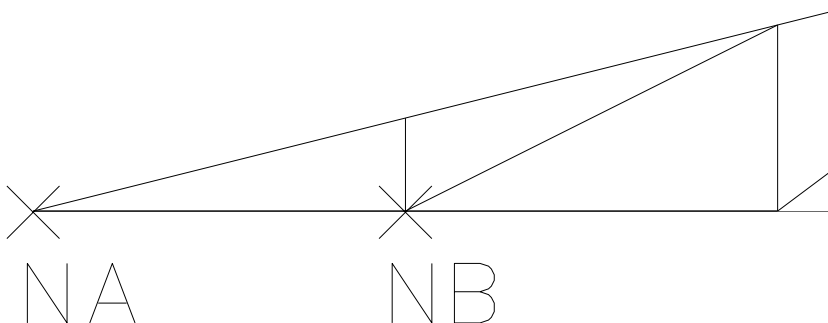

or enter coordinates directly from the command line:

Node NA (end+cen+nod+int+ext): **0,0, 0.0**

Node NE (end+cen+nod+int+ext): **2.5, 0.0**

Input schedule has influence. Local element axis starts in point NA and is directed to NB.

Beside end point coordinates number of the cross section should be entered i.e. prestressing force, as far as it exists.

Section number<1> or [Prestress force]: **2**

If section is not already defined in the command line following message appears:

+++ WARNING: Cross section not defined!

Cross section may be defined later.

Command: SOF_GFACH

Node NA (end+cen+nod+int+ext): **Pick point NA**

Node NE (end+cen+nod+int+ext): **Pick point NB**

Section number<1> or [Prestress force]: **2**

+++ WARNING: Cross section not defined!

First Truss beam No.<1>: **1**

Node NA (end+cen+nod+int+ext): **Pick point NA**
 Node NE (end+cen+nod+int+ext): **Pick point NB**
 Section number<2> or [Prestress force]: **Return**

+++ WARNING: Cross section not defined!

Node NA (end+cen+nod+int+ext): **Pick point NA**
 Node NE (end+cen+nod+int+ext): **Pick point NB**
 Section number<1> or [Prestress force]: **Return**

..... Enter all truss elements

As presented before, this method for creating truss finite elements does not allow to group elements. Entering element groups is done by modifying commands.

A more efficient method for creating structural elements is achieved using the command *Generate*. It allows simultaneous input of several elements with same properties. Also, with this command element groups are entered directly.

SOFIPLUS→Generate→With objects

Select *Truss* option in the dialogue box:

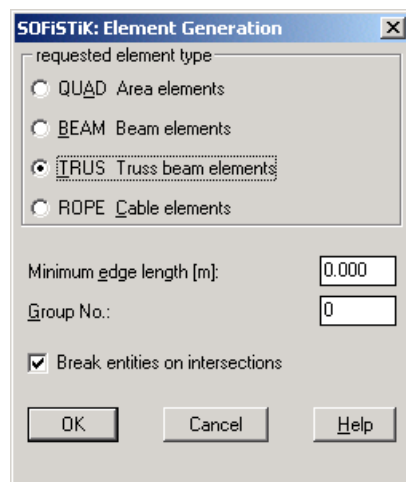

Minimum edge length [m]:

is filled with slab structures in order to specify minimum slab edge length

Group No.:

Enter group number which identifies the element. This value is multiplied with maximum element group number previously defined with general structure parameters (the command *Structural System...*) and the result is the start number of elements in the group. For example, if with the command *Structural system...* maximum element number is defined as 1000 and in the edit box *Group No.* value 2 is entered, then start number of the group has value 2000 (2·1000). In this example, our structure is simple and there are no element grouping, so group number is as default 0.

Break entities on intersection:

Define the method for treating the element intersection points. If this option is turned on then new point is inserted on the element section and elements are divided in two separate

elements. When this option is not active, elements are divergent. New point is not inserted and original elements remain unchanged.

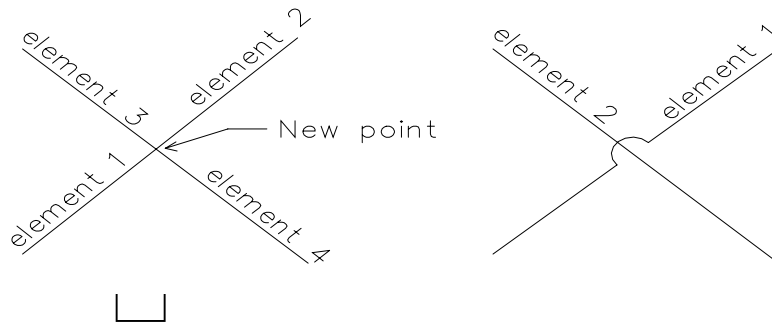

Break entities on intersection

Break entities on intersection

Perform selection on all objects (lines) which should be converted in truss elements.

Select objects:

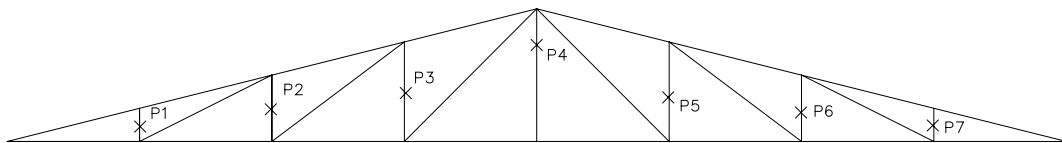

In relation to the option *Break entities on intersection*, a search for intersection lines is carried out and new points and elements are defined.

Searching intersections

Treating partial-lines ...

Making Elements ...

After this, enter the number of cross section for the input element group.

Section number<2> or [Prestress force]: 3

In dependence on number of already created elements and number of element group which are formed, SOFiSTiK offers first number of selected elements.

First Truss beam No.<9>:

You may accept the offered number or may enter a number which is not previously used.

1.10 SUPPORTS

When you create structural elements, at the end of the elements i.e. their intersection points are automatically defined as node points. These nodes are free by default and displacements are able to occur on any system degrees of freedom. Actually, supports are bonds which

restrain certain displacements. They are entered in the structure with the command *Modify Nodes*, which restrains displacements in determined directions.



ICON : Modify node
 MENU: SOFiPLUS→Modify finite element→Node
 Command: SOF_GNOTMOD

Select node points which have to be constrained in defined degrees of freedom.

Command:

Select option <Select objects>[Select objects/Enter number/Pick nodes]: p

Three ways to select supporting nodes are possible: by selecting the object (in this example node point), by entering the node point and by picking the node point. In this case the third way is chosen by picking the node point.

Nodes (end+cen+nod+int+ext): Pick point P1

Nodes (end+cen+nod+int+ext): Pick point P1

Pick the end points on the truss (P1 and P2).

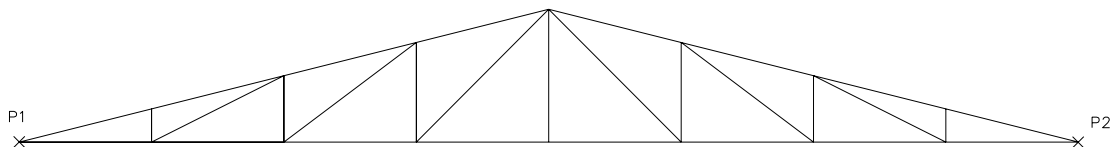

After choosing the appropriate points to represent supports, a dialogue box pops up on the screen where you should click to enter the proper displacements.

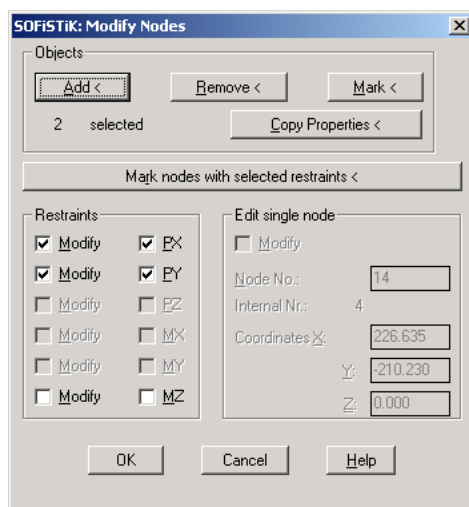

This dialogue box shows the number of selected node points (2 selected). By clicking on the button *Add* you return in the position to select new points to represent supports. Similarly with

the button *Remove* again you return in the position to select points, but the preferred points are deleted from the selected group.

In the current example, check the *Px* and *Py* boxes. This is to sign reactions in X and Y direction to selected node points, so you create fixed supports.

If you select only one node, *Edit single node* boxes are active. With them you are able to change node number as well as its position.

1.11 Info / Edit

INFO/EDIT is powerful tool to use with the purpose of viewing the main properties of structural elements with the opportunity to change them. For example, displacement in given direction can be constrained by using the INFO/EDIT command.



ICON : Info/Edit
 MENU: SOFiPLUS→Info/Edit...
 Command: SOF_G?????

Select the structural element you want to review or make a change in the properties. In this example, end left node of the truss is selected (node which has to act as fixed support). On the screen dialogue box is called up, where information for the selected element are shown. If the selected element belongs to few structural elements, only information for one element is shown.

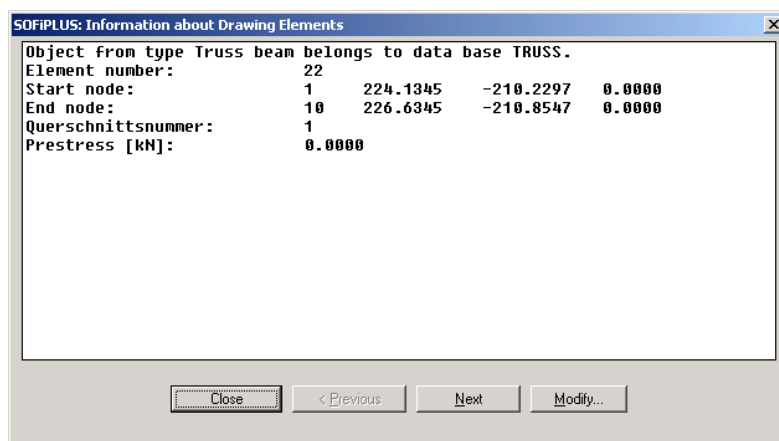

With the button *New* you are able to show information about the next element which has mutual point with the selected. By moving forward (*Next*) or backward (*Previous*) the element which you are about to change is displayed. In the current example it is node point.

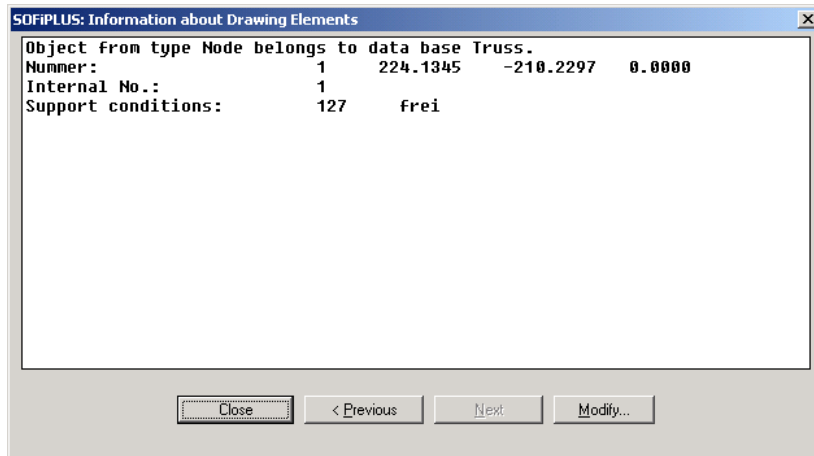

Click on the button *Modify* to begin with entering the changes in the element whose properties are presented on the screen.

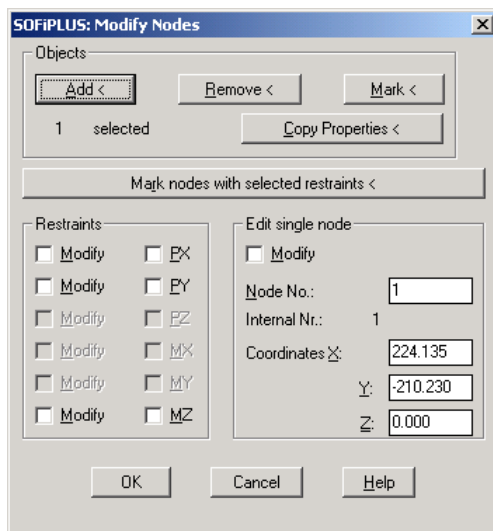

Mark the PX and PY check boxes to indicate that a point can accept reaction forces in X and Y direction. By clicking on the *Ok* button you continue with the selection of the next element which has to be changed. The following element may be truss element for which we want to display the data or to make a modification.

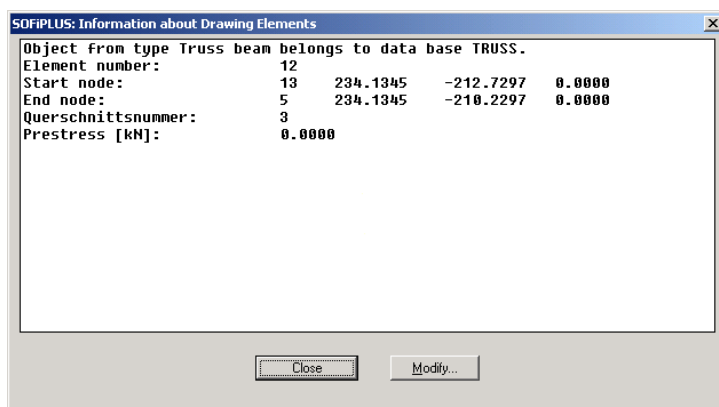

In this case everything is clear. Only one element connected with the selected object exists, so in the dialogue box buttons *Next* and *Previous* are disabled. Dialogue box called up by clicking on the *Modify* button allows entering the modifications of the selected truss element.

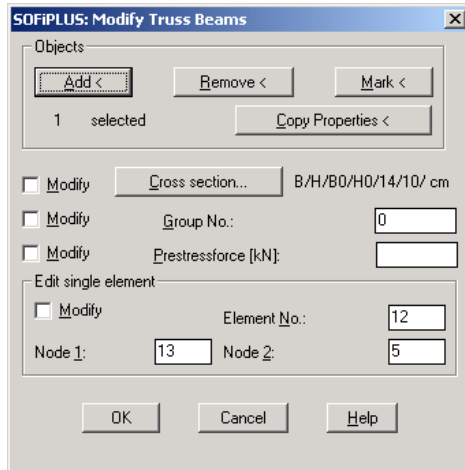

The button *Cross section* starts the dialogue box which contains the list of defined cross sections.

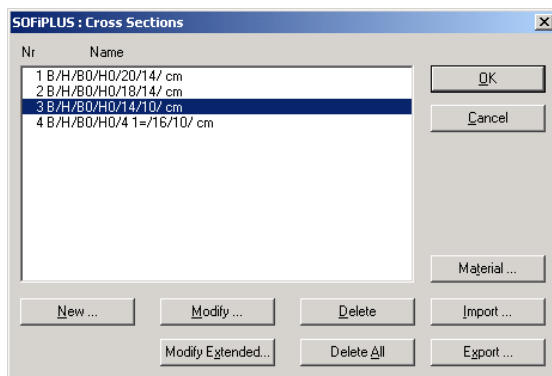

By choosing one of the sections presented in the list, modification in the element cross section is executed.

Beside element modification, change in the group for the element can be done or appropriate prestressed force can be applied on the element.

With the objects in the dialogue box, placed in *Edit single element* frame, you can make a change in the element ordinal number (*Element No.*) or in the numbers of its member nodes (*Node 1, Node 2*).

1.12 SUPPORT VISUALIZATION

(DISPLAY RESTRAINTS)

To display the supports in the structure their visualization in necessary to perform. Select the function *Display restraints* from the visualization menu.



ICON : Display restraints
MENU: SOFiPLUS→Visualize→Restraint
Command: SOF_GFEST

On the question:

Einstellungen? [Ja/<Nein>]: **J**

answer with J if you have to make change in the element size and color.

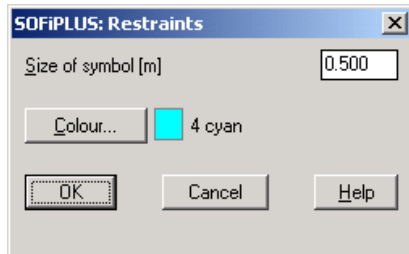

Choose new color and enter the symbol size to represent structure supports.

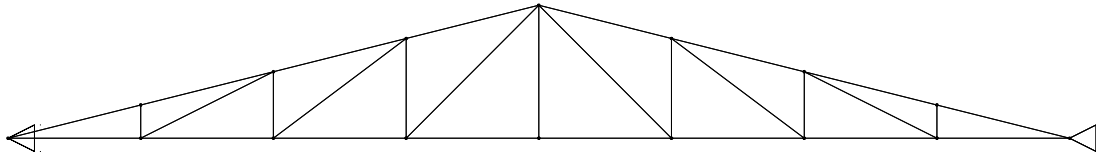

In case supports in the following steps entirely cover the drawing, to obtain better preview on the situation, you can hide them from the screen view port.

The command:

SOFiPLUS→Visualize→Delete visualization

starts the following dialogue box:

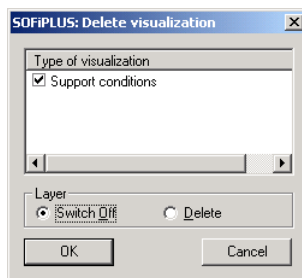

Check the *Support condition* check box and select the *Switch off* option to make the supports invisible. This action has influence only on supports visibility, so they are present in the structure and constrain the applied deformations. The same effects can be achieved using layers.

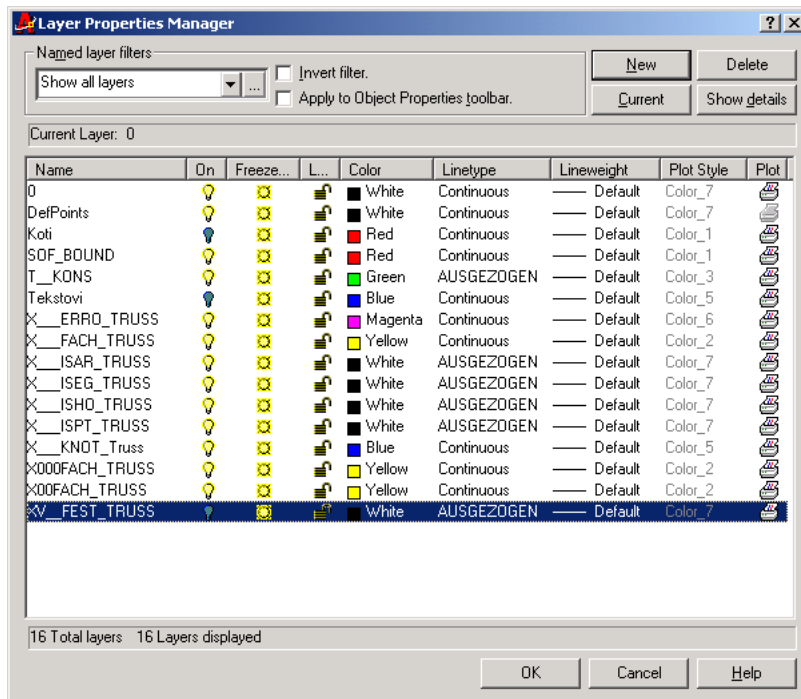

Supports are drawn in the layer XV__FEST_TRUSS (project name). By turning this layer off, supports are not displayed on the drawing.

1.13 LOADS

Before loading the structure, it is necessary to define all load cases.



ICON : Loadcase Manager
 MENU: SOFiPLUS→Loadcase Manager
 Command: **SOF_GLFMOD**

At the beginning the load case list is empty. With the button *New*, new load case is entered in the list. The list profile i.e. number of combinations depends on the implemented standards used for dimensioning the structure. First few attributes are common. Combinations and load factors are different for DIN and EC.

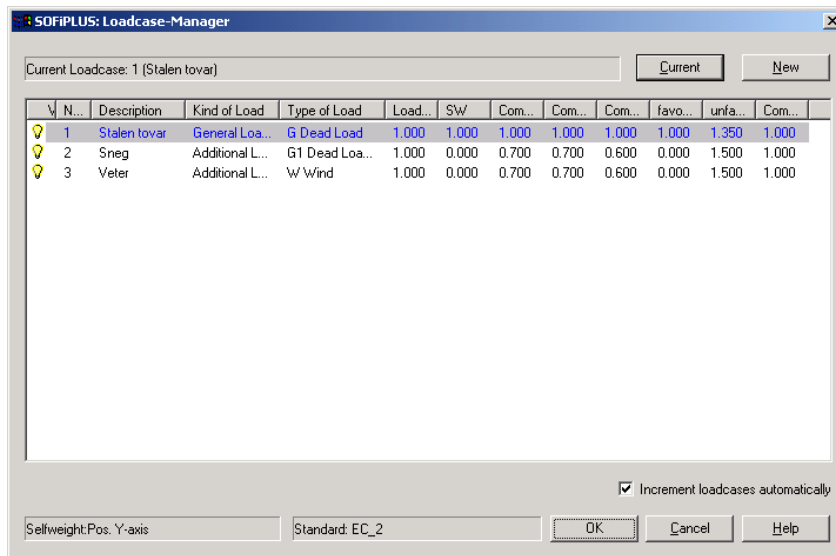

N Number of load case

Description Few words to describe the load case

Kind of Load It can be general, additional and special. Every national standard performs load classification and determines the group which load belongs.

Type of load Larger load classification is presented to define load combinations.

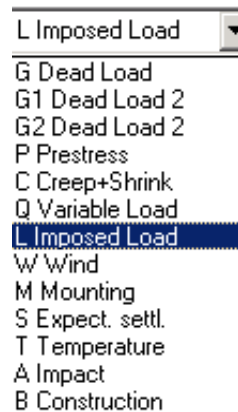

If self weight of structural elements is needed for particular load case then you should enter the proper factor SW (Self Weight). For instance, SW factor 1.00 means that the self weight of the elements is fully taken in determination of the loads for that load case.

For this example, three load cases are defined. They are shown in the *Loadcase Manager* dialogue box.

Before entering the loads for certain load case, it should be appointed as *current*. For example, to input loads in the *SNEG* load case, select it from the list and click on the *Current* button.

Loads are entered in the following steps which belong to *SNEG* load case.

For this example, first enter loads in the *Stalni tovari* load case to represent dead loads. Make *Stalni tovari* load case current. Load from the roof acts as uniformly distributed load along the length of the upper chord. Load direction is positive Y-axis direction. To enter this load use the following options:



ICON : Truss element load
 MENU: SOFIPLUS→Create loads→Truss element loads
 Command: SOF_GXLAS

Command: **SOF_GXLAS**
 Trusses to be loaded
 Select objects: **select elements from the upper chord**

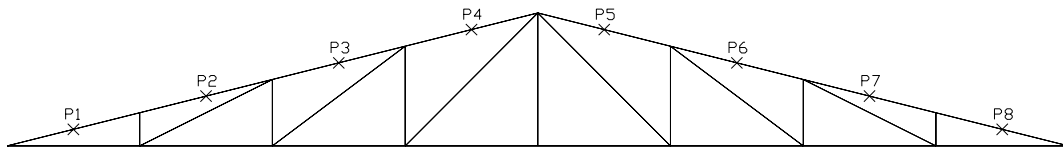

Select objects: **Return** to finish selection

Load type and direction [PX/PY/PXP/PYP/ES/TS/VS]: **py**
 Load value in kN/m: **1**
 Trusses to be loaded
 Select objects: **Return** to finish load input

PY Load acts along the whole element length in global Y-axis direction.

In the bottom at the center of the truss, a load with weight 2 kN is hanged up. This load acts directly in truss node. Entering loads from this type is done by:



ICON : Node Load
 MENU: SOFIPLUS→Create loads→Node Loads
 Command: SOF_GKLAS

Command: SOF_GKLAS
 Nodes to be loaded
 <Select object>[Select object /Enter number/Pick nodes]: P

Select the node by clicking directly on the node where force acts.

Nodes (end+mit+pkt+lot+ext): click on the point P1
 Nodes (end+mit+pkt+lot+ext): **RETURN**

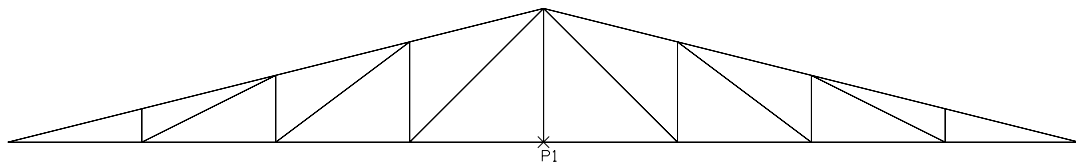

Load type [Load/Moment/Displacement/Rotation]: L
 L load type, concentrated force

Direction of effect [PX/PY/Zeigen]: **PY**
 PY load direction, positive Y-axis direction

Load PY in kN: 2 force value
 Nodes to be loaded

<Select object>[Select object/Enter number/Pick nodes]: **RETURN**

Input loads are displayed on the screen.

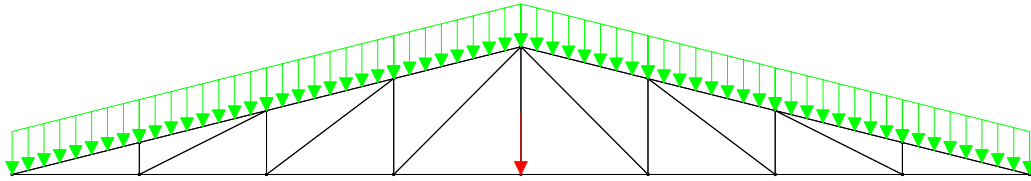

Before entering the loads for the next load case it is recommended to disburden the drawing with the loads from the previous load cases. SOFIPLUS creates separate layers for every load case.

XV__K???_database name, and
XV__X???_database name

K label for node loads
X label for distributed loads
??? number of load case
database name name of the analysis database

For the current load case create the following layers:

XV__K001_TRUSS, and
XV__X001_TRUSS

Make these load cases invisible with the AutoCAD function *Layer Property Manager*, by switching off the appropriate layer.

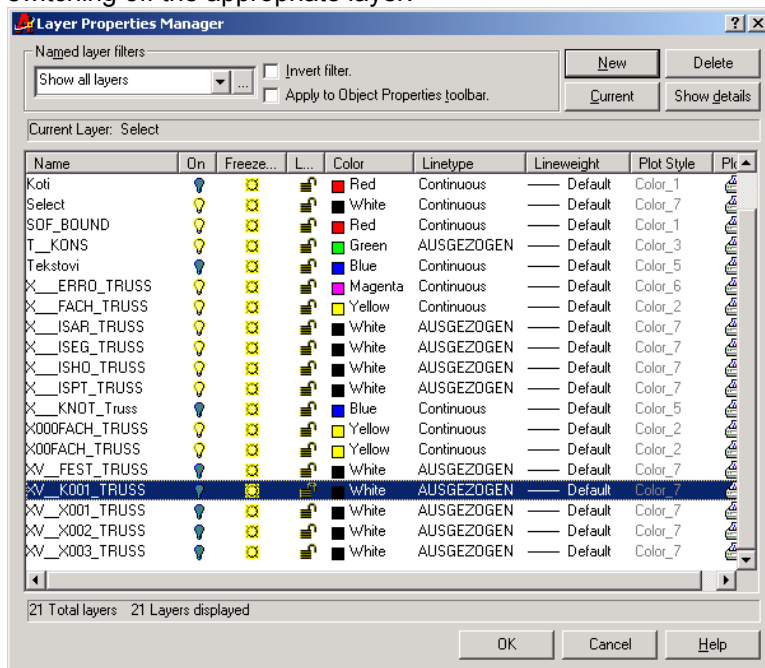

SOFIPLUS has its own command which allows turning off certain load cases from the view area.

SOFIPLUS→Visualize→Delete visualization

Select &Loads and Switch Off

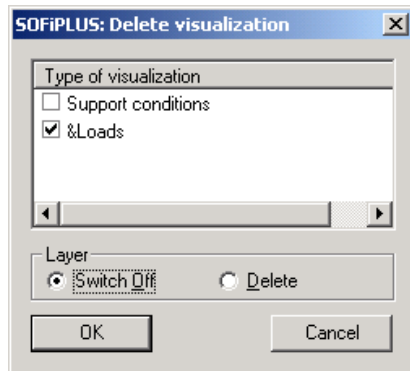

to turn off all load cases from the view area.

In the next step in *Loadcase Manager* put load case *Sneg* as current. With this action entering loads for the load case begins. Snow is proposed as uniformly distributed load which acts on single unit on horizontal area. For this truss snow acts on upper chord along the horizontal element projection.



ICON : Truss element load

MENU: SOFiPLUS→Create loads→Truss element loads

Command: SOF_GXLAS

Command: SOF_GXLAS

Trusses to be loaded

Select objects: select elements from upper chord

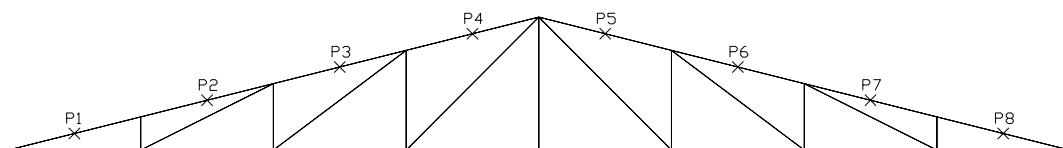

Select objects: Return to finish the selection

Load type and direction [PX/PY/PXP/PYP/ES/TS/VS]: PYP

PYP The load acts along the element projection in global Y-axis

Load value in kN/m: 1.875

Trusses to be loaded

Select objects: Return to finish the selection

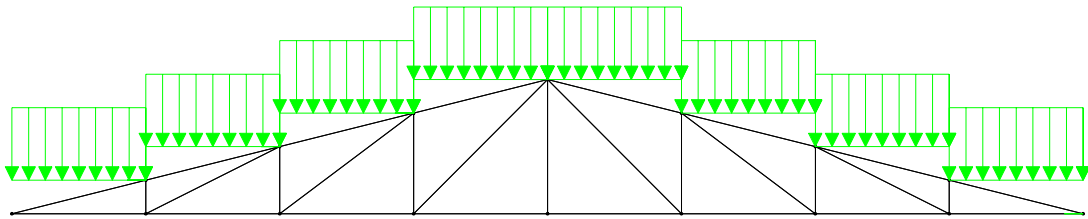

At the end in *Loadcase Manager* make load case *Wind* as current and start entering loads for this load case. Wind is set as uniformly distributed with intensity of 0.6 kN/m^2 ($240 \text{ N} \cdot 2.5 \text{ m}$) acting perpendicularly on the upper chord of the truss. The projection of this load is determined in direction of X-axis (0.582 kN/m^2) and Y-axis (0.145 kN/m^2) and this load is applied on upper truss elements.



ICON : Truss element load
 MENU: SOFiPLUS→Create loads→Truss element loads
 Command: SOF_GXLAS

Command: **SOF_GXLAS**
 Trusses to be loaded
 Select objects: **select elements from upper chord**

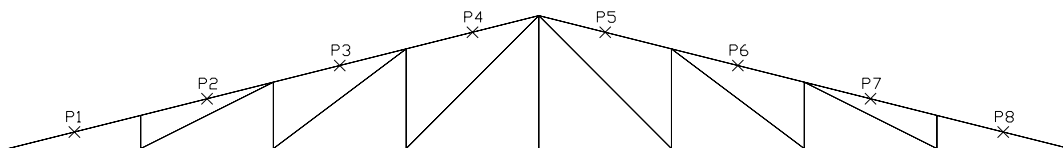

Load type and direction [PX/PY/PXP/PYP/ES/TS/VS]: **PY**
 Load value in kN/m: **0.582**

Trusses to be loaded
 Select objects: **select elements from the left part (P1-P4)**
 Load type and direction [PX/PY/PXP/PYP/ES/TS/VS]: **PX**
 Load value in kN/m: **0.145**
 Trusses to be loaded

Select objects: **select elements from the right part (P5-P8)**
 Load type and direction [PX/PY/PXP/PYP/ES/TS/VS]: **PX**
 Load value in kN/m: **-0.145**
 Trusses to be loaded

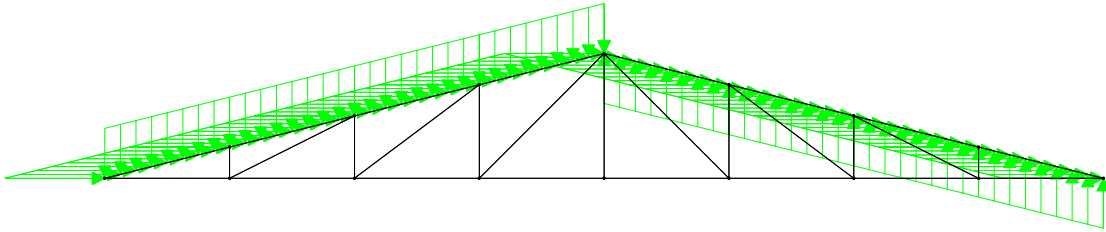

1.14 LOAD MODIFICATION

Sometimes it is necessary to make changes in the applied loads. Changes can be done in the size and direction of the loads, but also load can be moved or copied in other load case.

1.15 MODIFICATION OF NODE LOADS



ICON : Modify Node Load
 MENU: SOFiPLUS→Modify loads→Node
 Command: SOF_GKLASMOD

Determine a way to select the nodes in which load is modified.

<select object>[Select object/Enter number/Pick nodes]

Select object select more nodes using AutoCAD methods for selection *Box* and *Window crosses*.

Enter number enter node number

Pick nodes click on the node

A dialogue box opens where values for selected loads are shown. You can add new nodes to change the load, modify the load value or move the load in other load case.

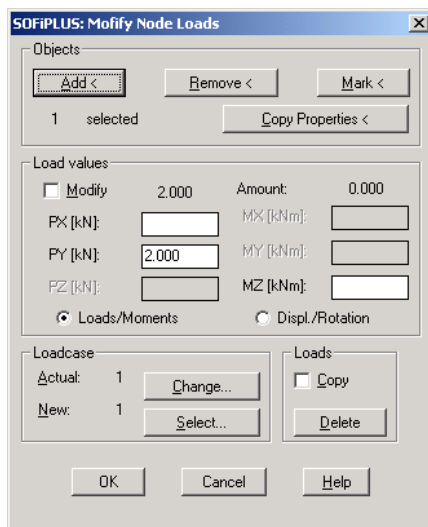

- Add/Remove adding/removing new nodes to modify the load
- Load values load values (Loads/Moments) or displacements (Displ/Rotation) are modified
- Loadcase select the load case to move the load
- Actual displays the load which contains the force

1.16 MODIFICATION OF ELEMENT LOADS



ICON : Modify Truss Element Load
 MENU: SOFiPLUS→Modify loads→Truss
 Command: SOF_GXLASMOD

The procedure is exactly the same as at node loads modification. The difference is only in the dialogue box which at this moment contains necessary blocks for modification of distributed loads.

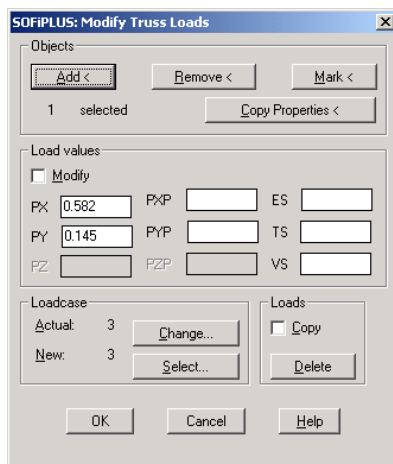

1.17 DATABASE EXPORT

Whenever elements to be modified are selected, or when warnings and errors are expected during data control, appropriate elements are marked.



ICON : VIZUALIZE→Toggle Display Mode ...
 MENU: SOFiPLUS→Markers→S-Toggle Mode
 Command: SOF_GERROR

Labeling can be permanent or temporary.

Command: SOF_gerror
 ++ HINT: Element marking permanently installed
 Command: SOF_gerror
 ++ HINT: Element marking temporarily installed

Temporary making is deleted at next zoom or Redraw. Permanent deletion can only be done with the command *Erase Layer* or *Erase Error Marking*.



ICON : VIZUALIZE →Export
 MENU: SOFiPLUS→Markers→Erase Error Marking
 Command: SOF_GDELEERROR

Before exporting the database you should make permanent marking of elements. (Element marking permanently installed). This way is much easier for the purpose of discovering elements which contain warnings and errors.

When you create the whole structure and when all load cases are entered, data should be saved in analysis database.



ICON : SOFiPLUS→Export
 MENU: SOFiPLUS→Analysis Data Base (CDB)→Export(..)
 Command: SOF_GENFOUT

The command *Export* transfers all data placed on the drawing into analysis database.

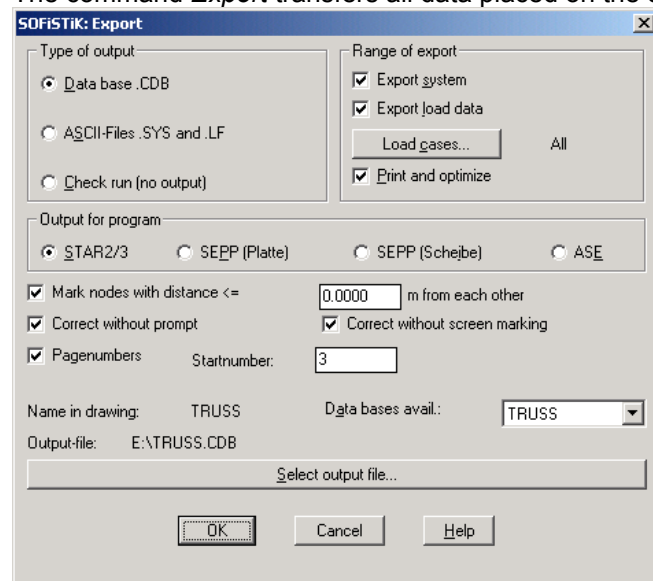

There is possibility to create output (ASCII) file or to perform structure control without creation of output file.

Data base .CDB – database is generated which contains all information about the system and the loads. Load cases are saved in text file (databasename.LF). Control is fulfilled in order to notice possible errors. By performing this command, few files are created:

- Databasename.CDB – database created by the program;
- Databasename.DWF – drawing with structural system and loads;
- Databasename.DAT – file used at calculation start;
- Databasename.ERG – program generates resultant file GENEFF;
- Databasename.LF – input file which contains load factors;

- Databasename.MSH – input file for the program SOFiMESH.

The load factors file (Databasename.LF) can be used directly in the static calculations.

ASCII files. SYS and LF. Output system information and applied loads are saved in text file (ASCII). This command creates following output files:

- Databasename.CDB – database created by the program;
- Databasename.DWF – drawing with structural system and loads;
- Databasename.DAT – file used at calculation start;
- Databasename.LF – input file which contains load factors;
-

Databasename.SYS - input file for the program GENEf.

Check run (no output). Data are checked for possible errors. Few mechanisms for data control are implemented. For example, nodes deleted by mistake and connected with the elements, are recovered or two nodes which are contained in one point are connected and etc.

Range of export. Controls which data will be exported. System, individual or all load cases. The *Print and optimize* button controls the output file *.LST* and performs optimization of the width in the system stiffness matrix band. Because this process consumes plenty of system time, this option has sense to execute it at the end of the calculation.

Output for program. Defines for which program module data are exported. Pre-selected is the module that depends on the structural system (STAR2/3-Frame, SEPP-Slab/Plate, ASE-Space).

Mark node with distance \leq ... from each other. All nodes on a distance smaller than specified are marked.

Correct without prompt. Defines if correction of errors will be automatic or for the modification program should ask for a verification.

Correct without screen marking. Controls if check is accomplished with marking the correct elements.

Page numbers. Allows entering number for the first page. Numbers of the resultant file are increasing starting from the entered number. If numeration of pages is not necessary, disable this option.

Data bases available. Amount data base list connected to the drawing. Selection of the database is executed by double clicking on the name from the list.

Output-file. Enter the output file name.

Select output file... Standard Windows dialogue box is called up to select the output file.

1.18 ANALYSIS

Analysis is performed with the program *WTEDY*.



ICON : Edit (Win Ted)

MENU: SOFIPLUS→Analysis ...

Command: SOF_G

At start of this module a dialogue box is called where you should enter input data base name (databasename.DAT), which is created while exporting the data.

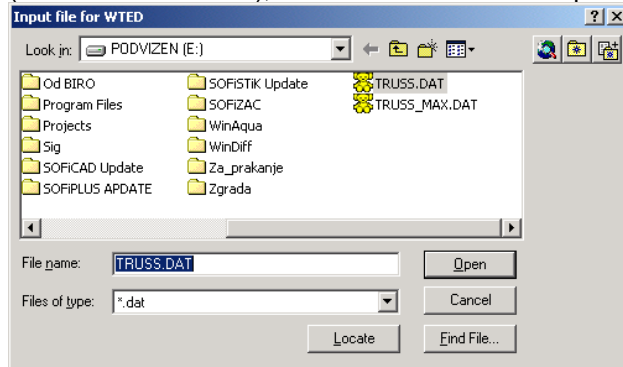

In this example it is TRUSS.DAT file. After the file selection, you are able to enter working environment of the *WTED* program. The program disposes of large number of functions which control the calculation and make selection and way of displaying the results. By its activation, input file is loaded in the editor. You can modify this file additionally in order to turn on operations which are not implied by default options or change some parameters in default options.

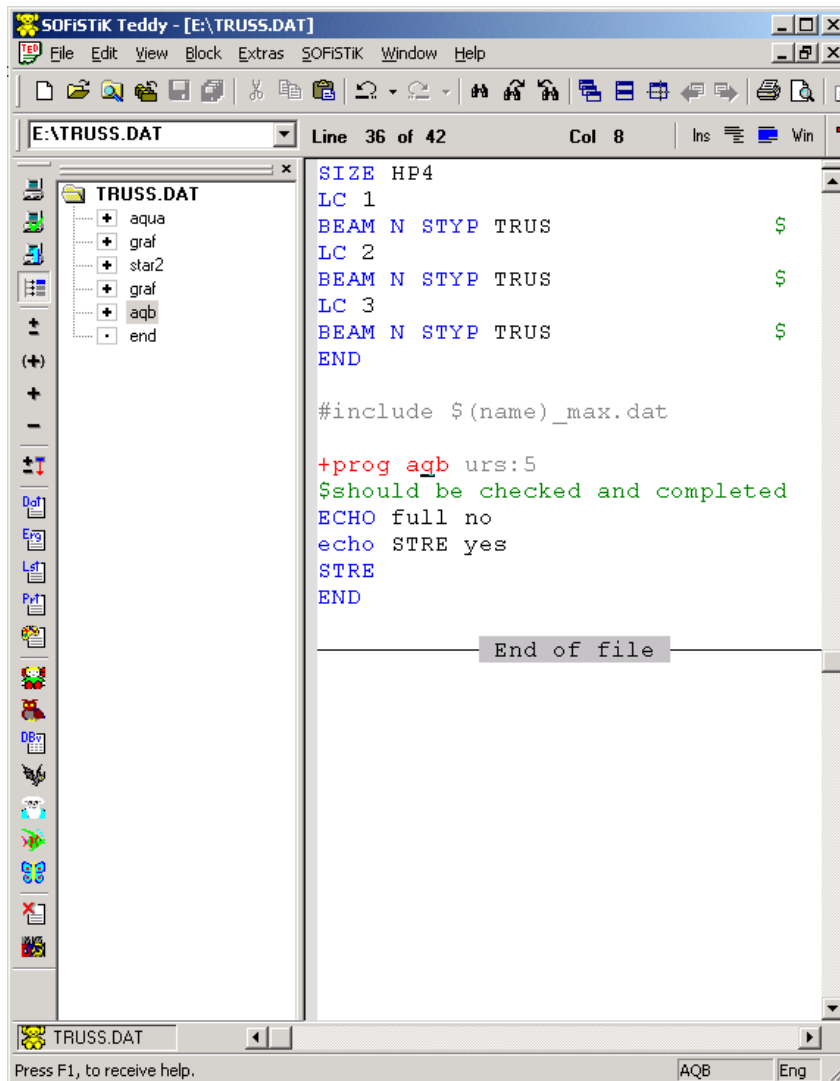

From the input file it is obvious that calculation activates several program modules: AQUA, ATAR2, GRAF, MAXIMA, AQB and END. The list of default program modules depends on the chosen structural model. It can be extended, but some modules not in use can be removed. For this example, you can remove MAXIMA, that determines the enveloping of maximal and minimal values as a result from load combinations. You should have some experience with these modules in order to make corrections in them. In the current example, you will make change in the second module GRAF. By default this module shows results only from the first load case (LC 1). Beside that, by default this module shows transversal forces, axial forces and moment on beam elements (BEAM VZ, BEAM MY, BEAM N). Because this example deals with truss structure, they are omitted, so their place takes:

```
LC 1
BEAM N STYP TRUS      $
LC 2
BEAM N STYP TRUS      $
LC 3
BEAM N STYP TRUS      $
```

In the graphic output file results for axial forces from three load cases are shown. Program AQB by default calculates stresses in the system.

In the list of modules:

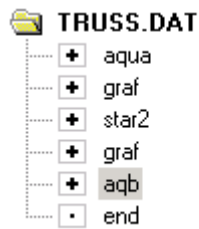



sign “+” denotes that module is included in the calculation. By clicking on it, module sign converts to “-” which indicates that the module is not taken in the calculation. Thus, user is able to control programs which participate in the calculation. Three icons start the calculation process:

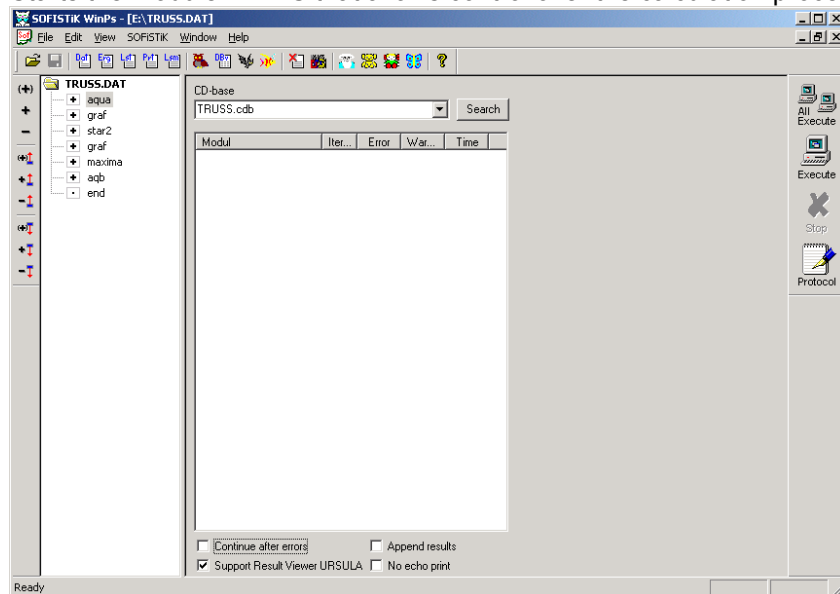

Starts the module WinPS that allows control over the calculation process



	<p>Starts directly the calculation. All modules with “+” sign are taken into the computation.</p>
	<p>Only module where cursor is positioned is executed.</p>

2. WORKING WITH THE ANIMATOR

Animator is usually used for visual control of the structure and output results. It can be started from AutoCAD using the SOFiPLUS Tools.



or from WinTeddy working environment.



Animator starts a graphical window where structure is shown.

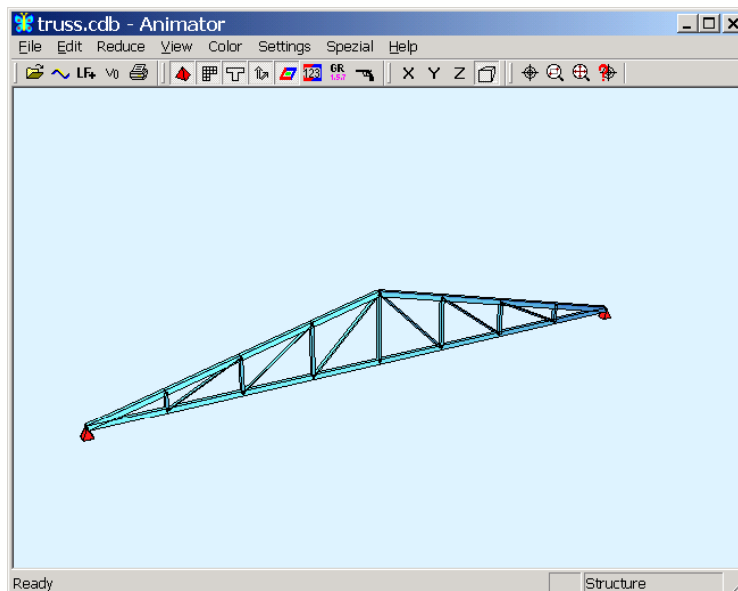



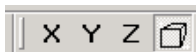

By simply dragging the picture (click on left mouse button, hold down the button and move around within the window) you can shift the view point of the structure.

The following tools:



enable different structure views.

	horizontal projection
	vertical projection in Y-Z plane
	vertical projection in X-Z plane
	perspective view

In case certain parts of the structure have to be displayed in larger scale, following tool may be used:

	zoom to point,
---	----------------

with whom part of the structure which has to be displayed in larger scale is pointed.

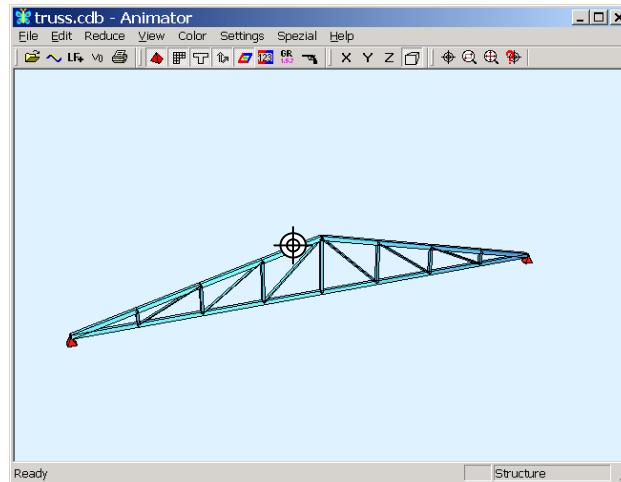

Effect from this action are shown below.

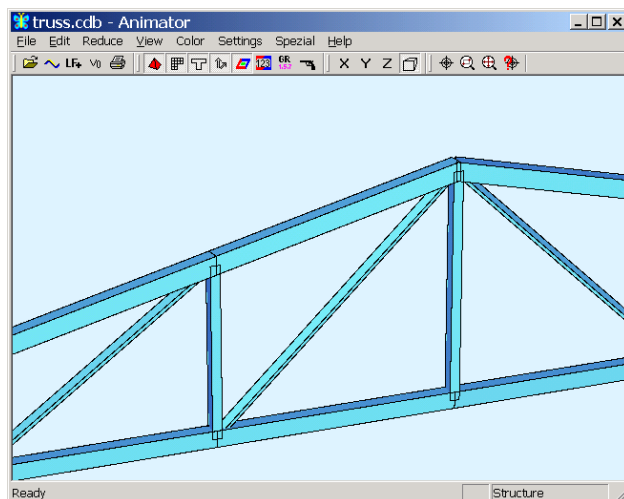

Next two tools are classical AutoCAD tools,



zoom window and zoom extend.

Their usage is well known to every AutoCAD user and therefore they will not be explained.

Next tool



Element info

allows obtaining information about geometry i.e. forces in certain element.

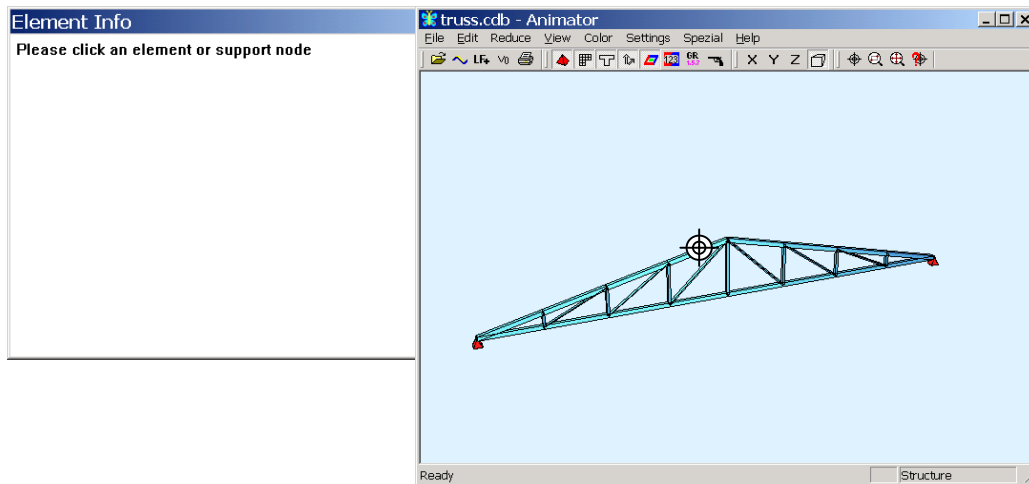

Dialogue box pops up on the screen asking to point the element i.e. support which detail information are needed.

Displayed results depend on momentary selected option.

Tool,



allows displaying the structure and deformed shape of the structure in separate load cases.

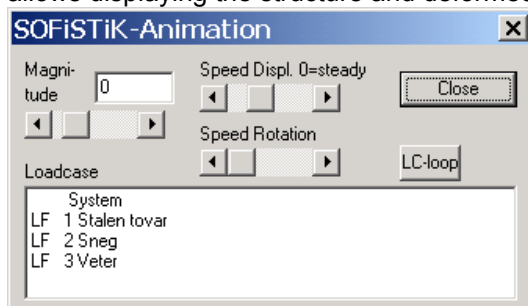

If you select a load case, for example *LF 1 Stalen tovar*, with the slider *Speed Displ. 0=steady*, you are able to regulate animation speed i.e. displacement of the structure at load case *Stalen tovar*. With slider *Magnitude* deformation magnitude can be changed while with slider *Speed Rotate* animation is proceeded by rotation of the structure.

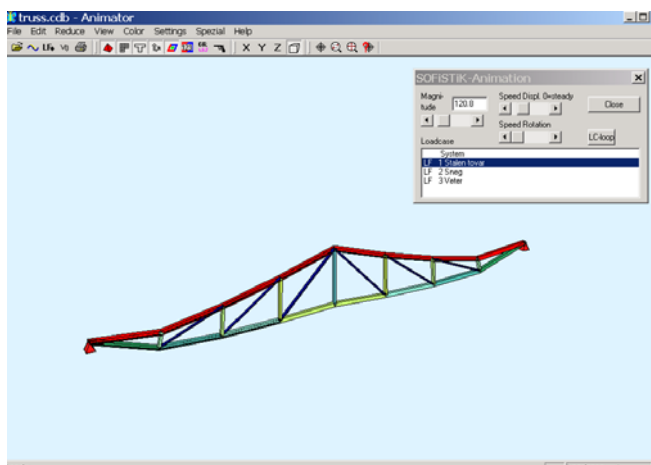

If slider *Speed Dipl. 0=steady*, is placed in initial position or icon is clicked, then deformed shape of the structure is shown including legend



where

stress changes of the structural elements are presented in different colors with their maximal values.

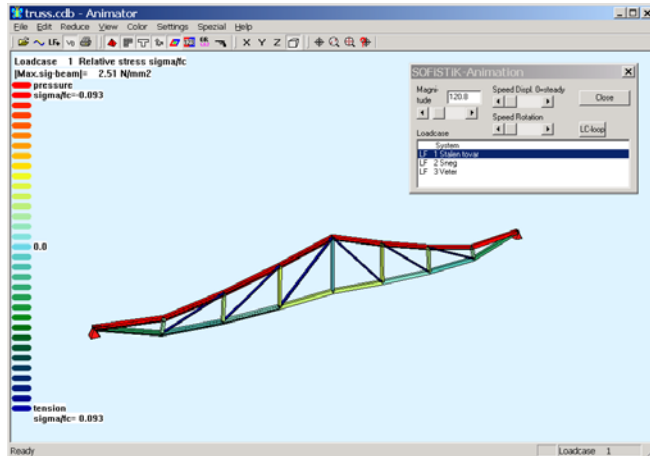

The tool



Next loadcase

displays animation for the next load case.

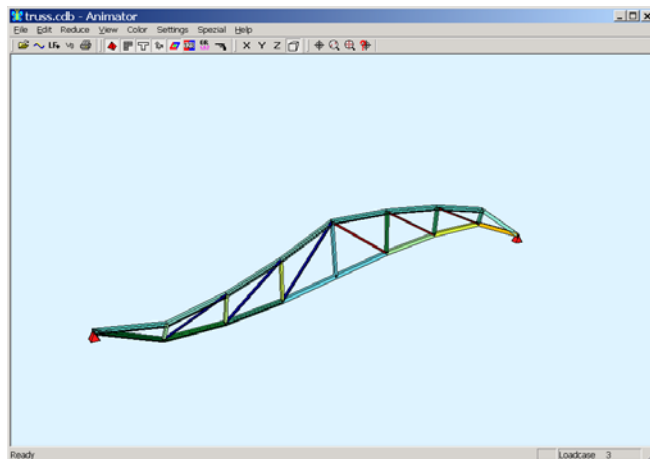

While running the animation detail information for certain structural elements can be acquired. For this purpose it is necessary to activate the tool



Element info



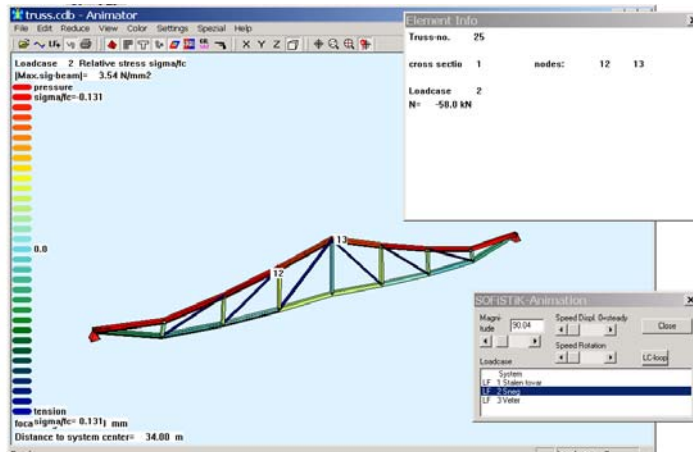





On the screen and in the additional window selected element information are shown.



The next group of tools



have influence on the way to display the structure. Some of them work with toggle mode. With one click they are turned on and with the next they are turned off.

	View support symbols	Supports are shown in larger or smaller scale size
	View separation lines	Finite element mesh is shown
	View cross sections	Structural lines are shown by one line or in true size
	View coordinate-systems	Local coordinate systems for structural elements are displayed
	Colored result Off/On	Elements are shown in different colors depending stresses inside them
	Colored result 1/2/3=relative/...	Way to display stresses at nonlinear analysis
	Group + box selection	Displaying different groups
	Shoot one group [except=deselect]	Switching off certain element groups from the view port

3. WORKING WITH WinGRAF

WinGraf is a module for graphical presentation of the structure and results. With help of WinGraf module, a drawing book is created. Three drawing categories are available: structural system, loads and results. You can start the program from the SOFIPLUS menu in AutoCAD or from *WinTedy* module.



ICON: WinGraf

MENU: SOFIPLUS→Graphical output→Graphical output... Command:

The operating environment of the program is shown in the following picture.

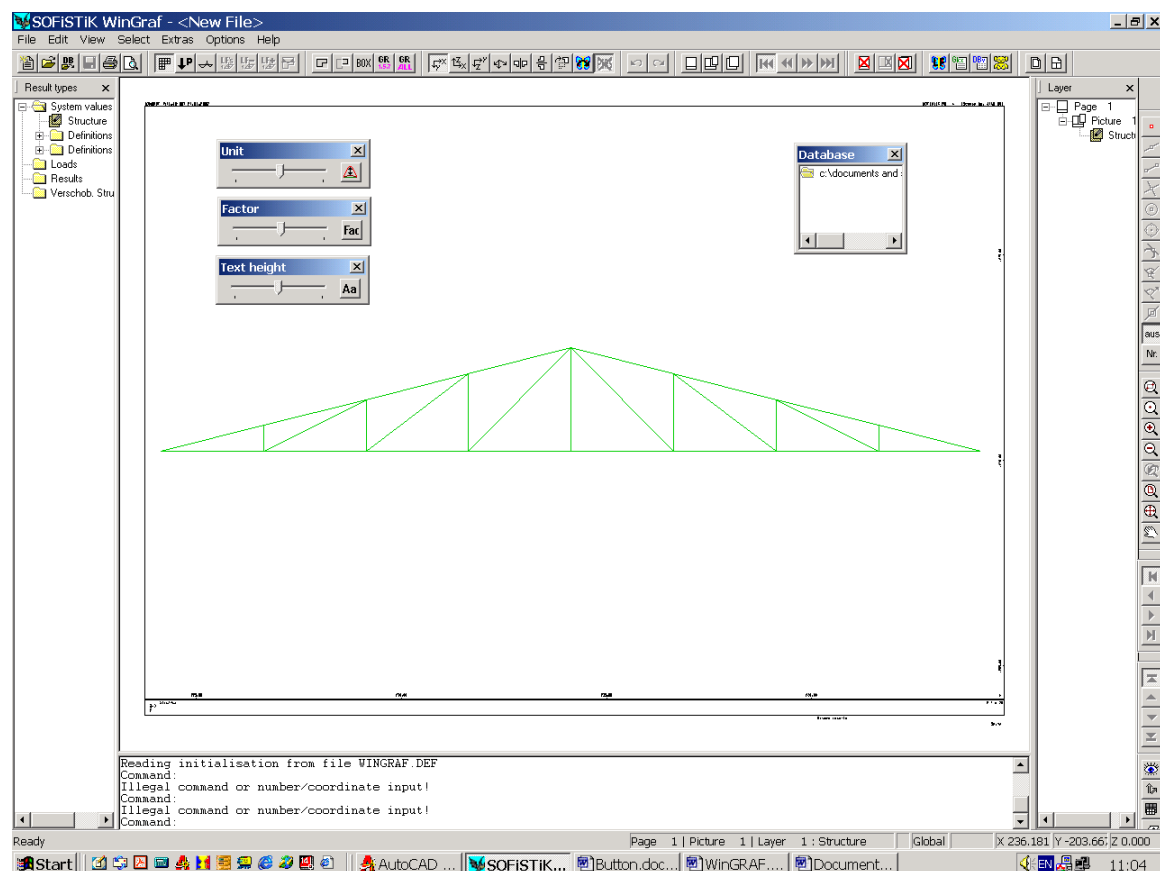

The central part of the screen is occupied by the graphical display where by assumption, drawn structure is shown. With this action, the first page from the drawing book is entered automatically. Program has a large number of functions for controlling the manner of showing graphical elements from the drawing.

First, you should determine drawing format. The routine is similar to standard Windows applications.

File→Page Setup

A dialogue box is called up on the screen that allows selection of the format, borders and drawing orientation. The same effect can be attained by double clicking with the mouse on the tab you want to modify, in the right part of the screen in the operating environment *Layer*. (in the example *Page 1*).

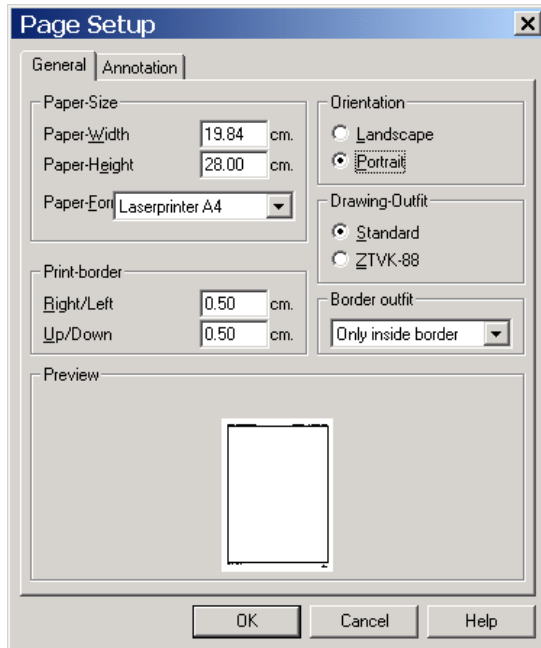

In the *Annotation* tab you can adjust text properties and select the language you will use for displaying the results as well as the basic color during the drawing.

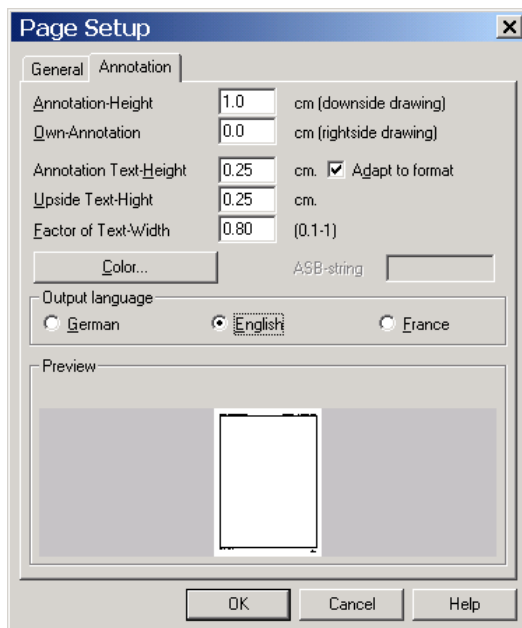

Regarding the current example, paper format is *A4* an orientation is *Portrait*. The rest parameters are as default.

Commonly one drawing is placed on one page. For this example, three structure drawings are placed on the first page. The first is with nodes, the second with element numbers and the third is with labels for cross sections of the elements. You can change the size and layout of the drawings on several ways. By double clicking on the drawing, you mark the drawing and eight red squares appear in the pages with drawings in corners and center. The size of the drawing can be modified as at standard *Windows* applications. Move the mouse on a square to change the drawing size and drag it to the direction you want to change the drawing size.

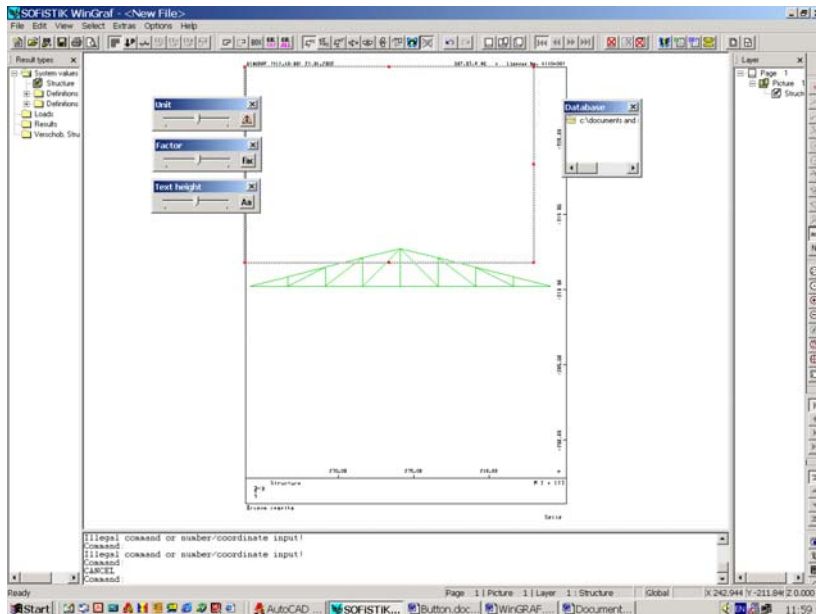

Since you attain the desired drawing shape, click on the button *Entry* to adjust the drawing according to the new appearance.

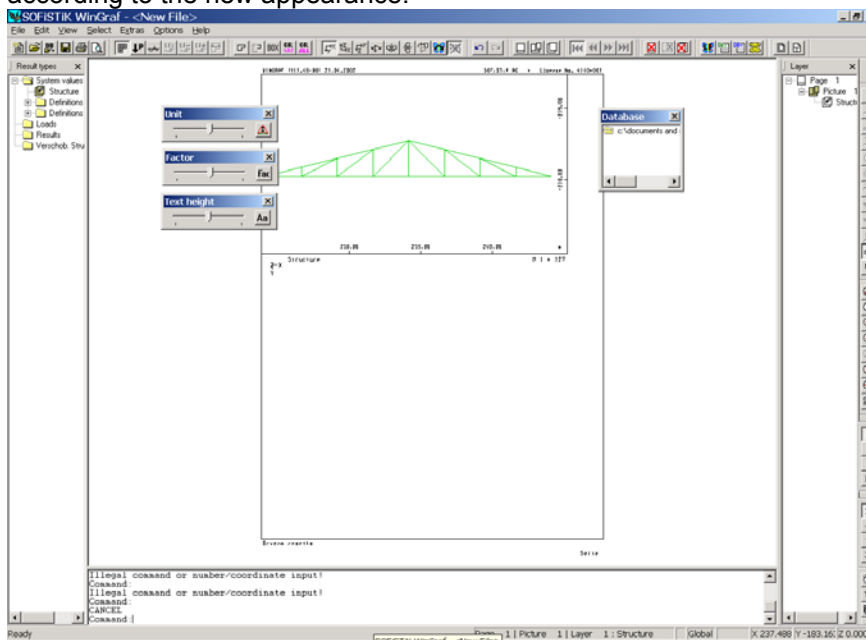

Another way to change the drawing size is to use the standard drawing forms. Click with the right mouse button in the graphic area. Short menu appears on the screen

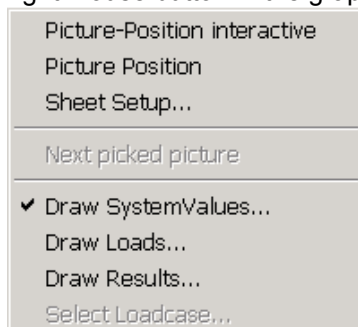

wherefrom you should select the option *Sheet Setup...* The same effect is acquired by double clicking the picture that you want to change, shown in the *Layer* operating area (in this example *Picture 1*). The *Drawing Setup* dialogue box enables setting up several drawings on one page, defining page head line (*Head Line* tab) and positioning the accompanying texts (*Annotation* tab). Concerning this example, three drawings are positioned along the height of the page (*Number of Pictures*, *Height 3*).

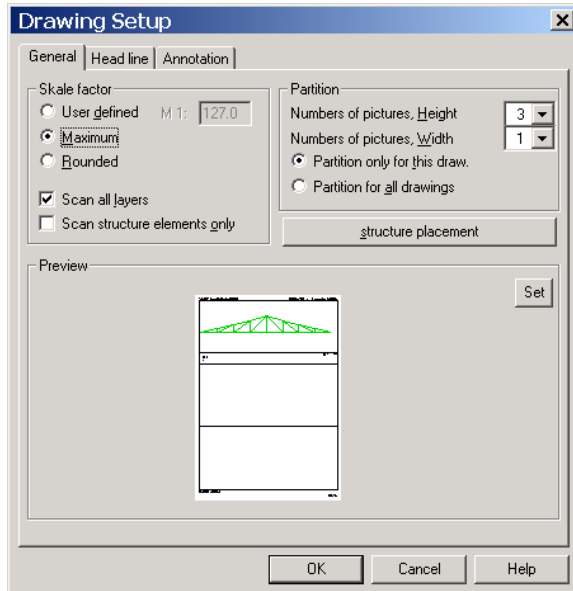

The button *structure placement*, defines the orientation of the structure in the drawing. In this example, it is set as default i.e. in the middle of the drawing.

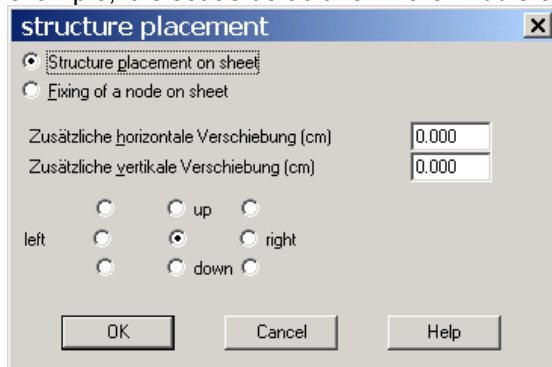

The button *Set* enables defining of the views,

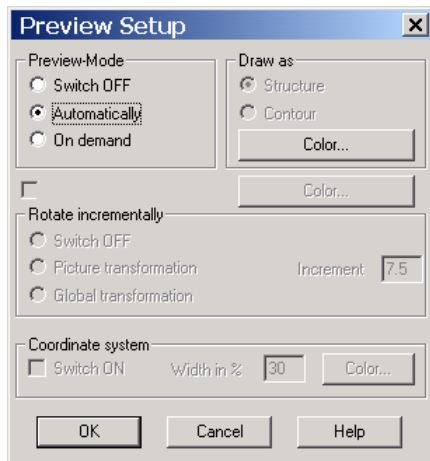

and displayed colors.

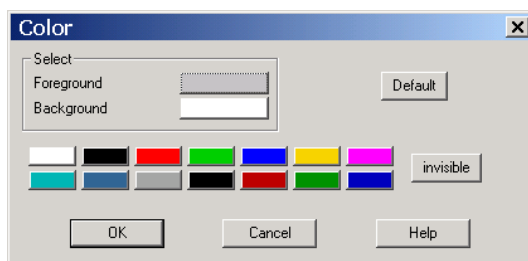

In the current example, they are set as default. You can enter elements in the drawing on two ways. The first is in the left part of the screen, so you should check the *Numbers of nodes* square box in the *Result Types* operating environment.

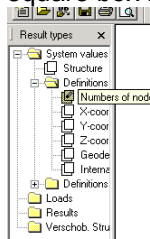

The second way is by clicking on the icon:



Draw System Variables

and selecting system variable to be drawn in the dialogue box, in this example *System variables*→*Definitions*→*Numbers of nodes*.

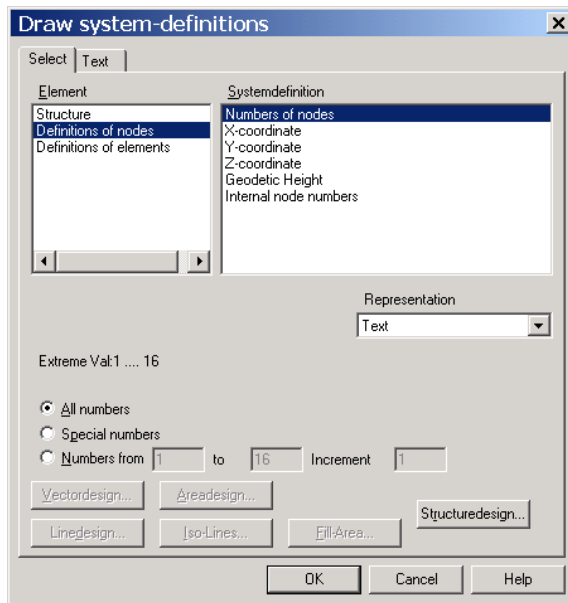

Text tab allows adjustment of parameters in the text used for displaying the numbers.

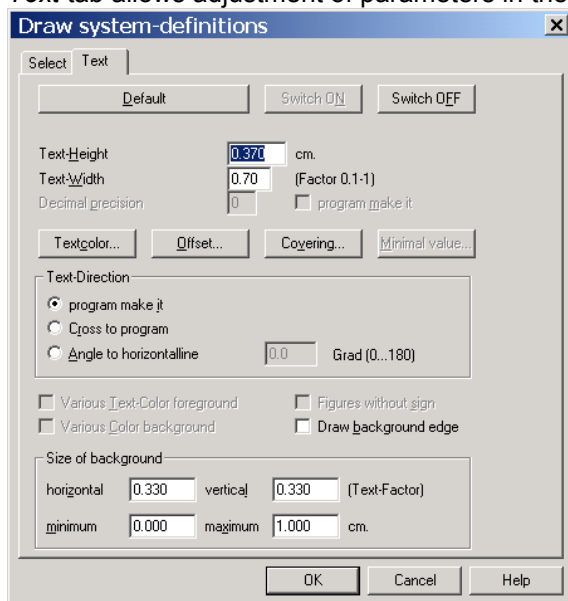

As a result of the previous operations, node numbers in the structure are displayed.

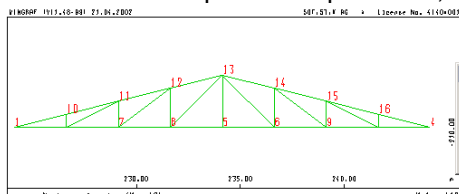

Since you enter numbers in the drawing, you can use the slide bar *Text height* to quickly change letter size.



The button *Aa* calls up the *Draw system-definitions* dialogue box for detail layout of the text properties.

In the next steps, new picture will be placed in the page. The drawing will contain the structure with the numbers of structural elements.



ICON: New Picture
MENU: Edit→New Picture

By assumption, *WinGraf* inserts new picture with the same content as the last created picture. To modify its content, you should define the system variable in the drawing, using one of the previous two explained methods, so in this example shows node numbers.

Through the *Result types* operating area

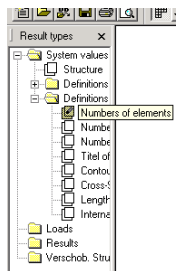

or the icon



Draw System Variables and Draw system-definitions

select Definitions of elements→Numbers of elements.

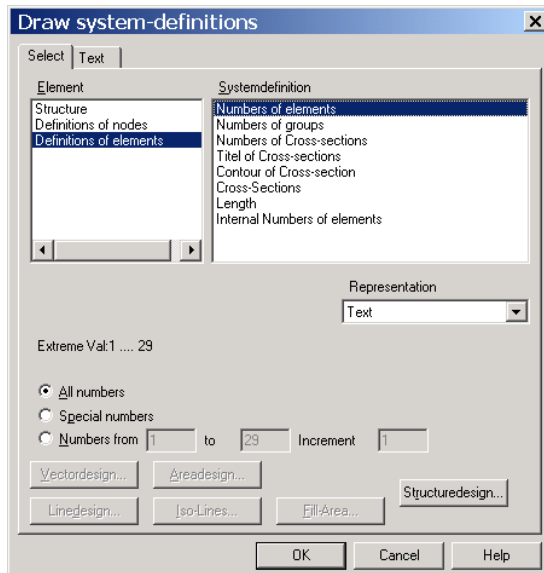

You can create the third drawing similarly to the previous method, so it will display numbers of structural elements cross sections.

Draw system-definitions→Definitions of elements→Numbers of cross sections

The final look of the first page is shown in the following picture:

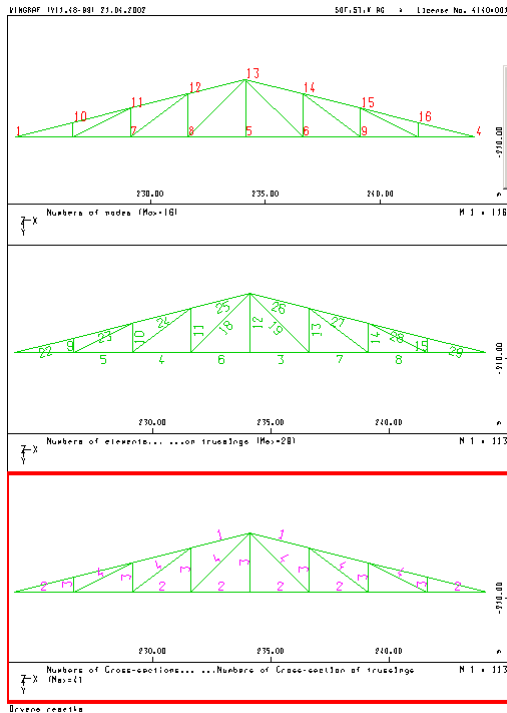

On the next page, you will place the structure and its loads. In the three pictures located on the second page, the three defined load cases are displayed. New page (sheet) is inserted by:

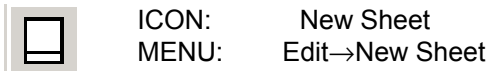

The new sheet starts with the same drawing schedule, as defined on the previous page, as well as the same first drawing as the last created.

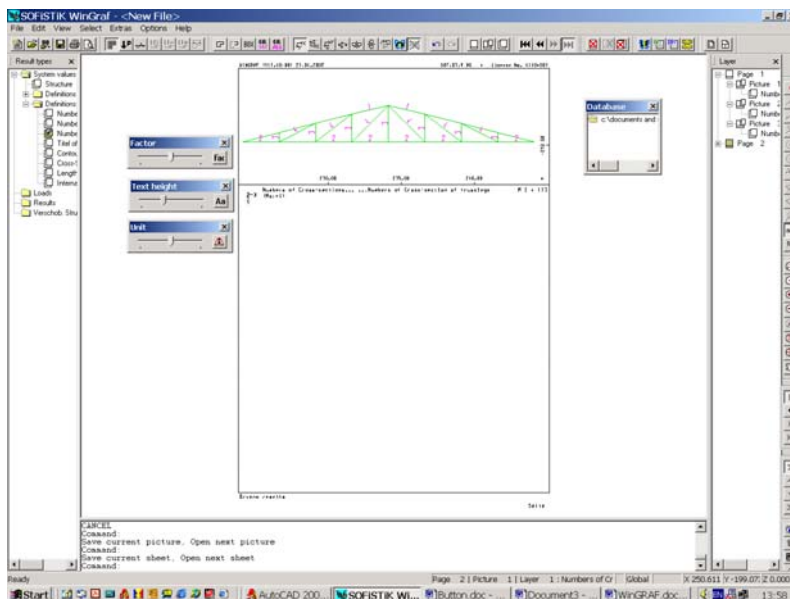

The new page is inserted in the book contents, showed on the right part of the screen in the Layer operating environment.

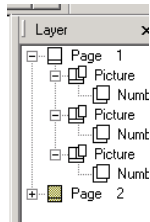

Introduction of the loads in the drawings follows the same procedure as for system variables. Select *Loads* in the *Result types* operating area

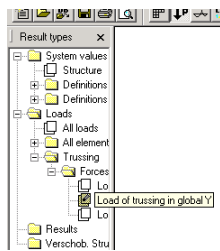

or click on the icon



Draw loads

to start Draw loads dialogue box and to select Trussing→Forces→Load of trussing in global Y.

Select *1:Stalen tovar* from the *Loadcase* combo box.

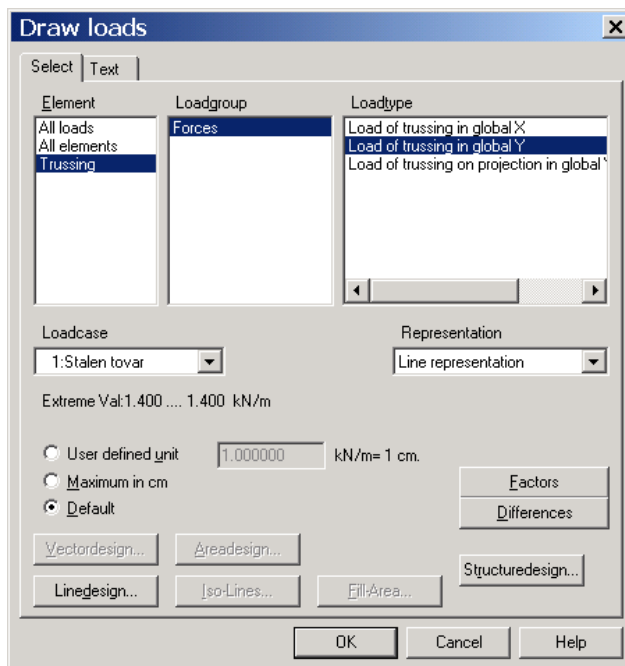

Representation combo box allows several ways of showing the results.

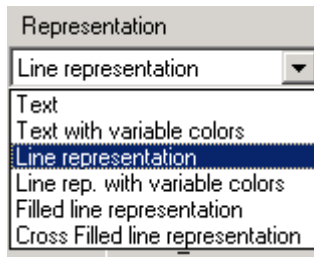

For the second load case, choose the load direction along the projection of the global Y-axis.

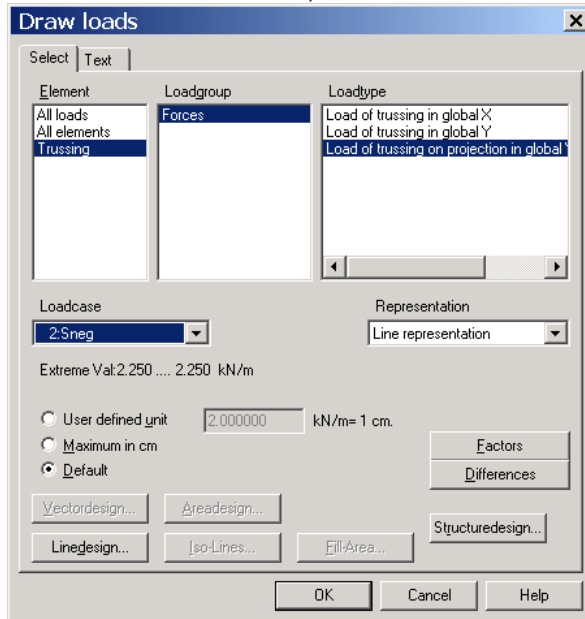

The third load case is characterized with loads in direction of global X and Y axes. Each of these load cases is placed on separate layer. Initially, load in global X-axis direction is shown.

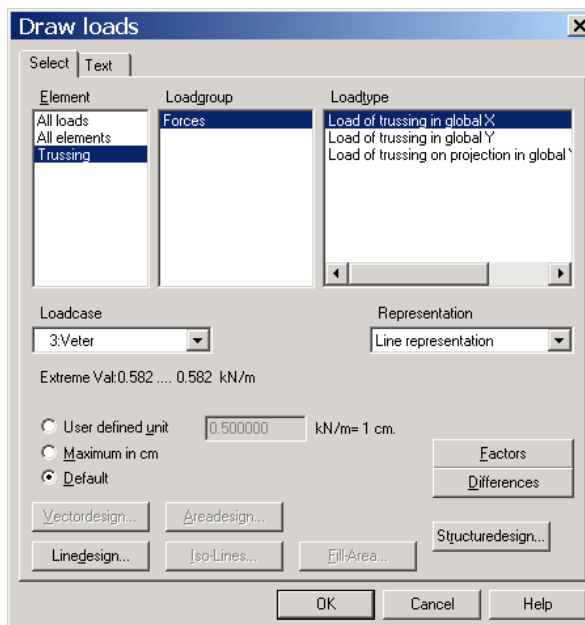

Results of the already entered loads are shown on the following picture.

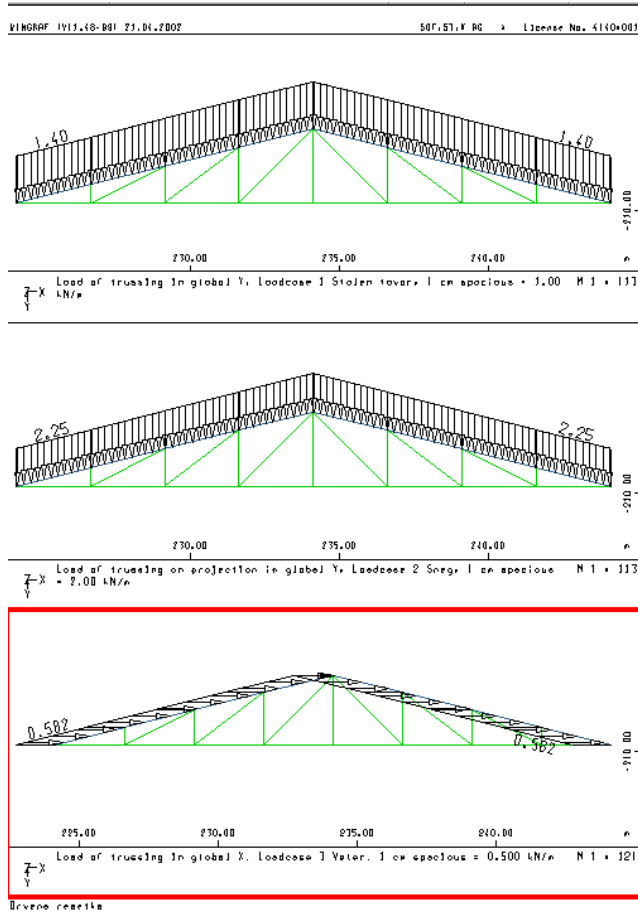

New layer is activated with:

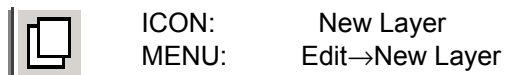

The procedure is repeated as when entering the load in global X-axis.

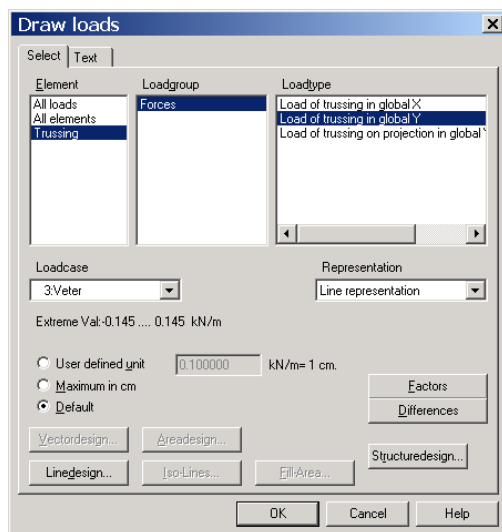

New load is presented in the last drawing.

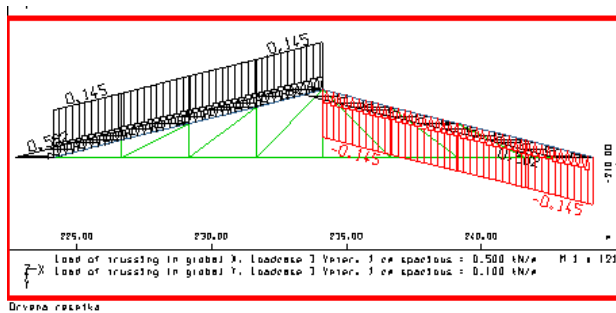

Simultaneously the drawing 3 of the second page is demonstrated in the book content to have two layers.

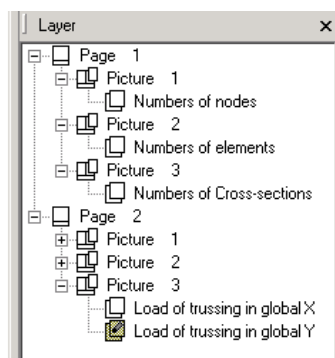

Reactions in the supports will be shown on 6 drawings placed on one page. Each support will be shown on separate layer. First, insert new sheet in the book.

- ICON: New Sheet
- MENU: Edit→New Sheet

Assuming, the new page maintains the format of the previous one, namely it has three drawings disposed by the page height. In order to make a change we can use the icon:

- Sheet setup,

or to double click the text *Picture 1*, in Page 3, from the *Layer* operating area. In the *Drawing setup* dialogue box,

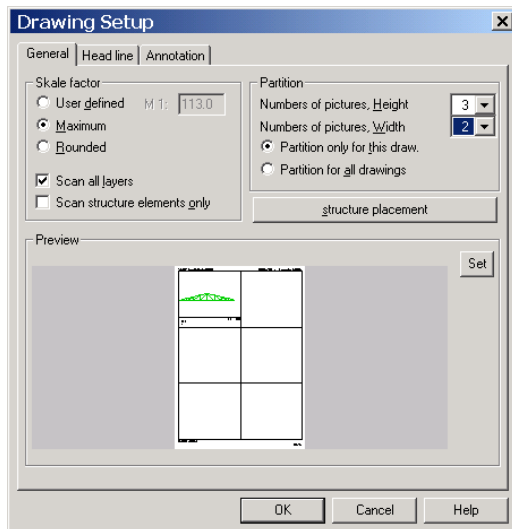

set the number of drawings along the width 2 (Numbers of pictures. Width). Reactions are positioned in the third category of drawings *Draw results*.



ICON: Draw Results
MENU: Select → Draw Results...

Select the following options in the dialogue box.

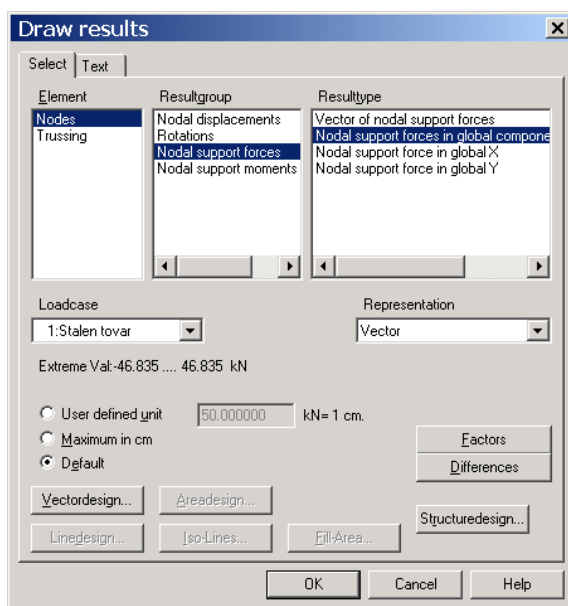

Element Nodes
Resultgroup Nodal support forces
Resulttype Nodal support forces in global component
Loadcase 1:Stalen tovar
Representation Vector

The drawing gets new form with signed reactions in the supports.

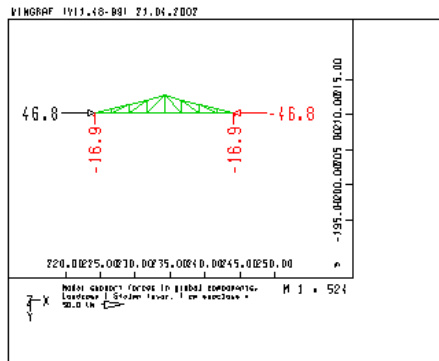

The idea is to show every support in one window. For that purpose you should change the outlook of the drawing.
The icon



Box

enables zooming of the part of the drawing which is to be shown in the next outlook. By clicking the left mouse button, a rectangular frame is drawn which embraces the part of the structure to be shown by the new outlook.

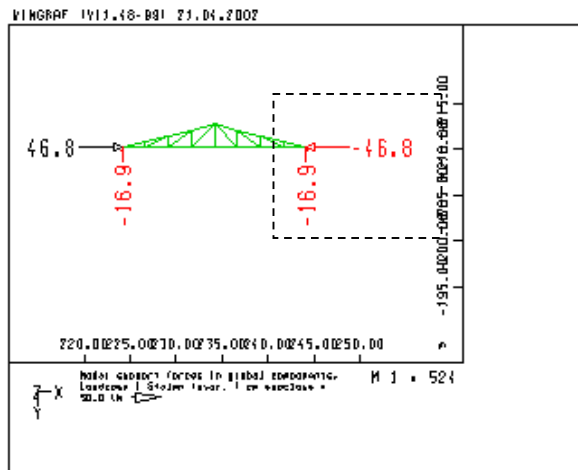

After releasing the mouse button, the drawing changes its content and demonstrates the elements of the structure which were entirely placed in the selected frame.

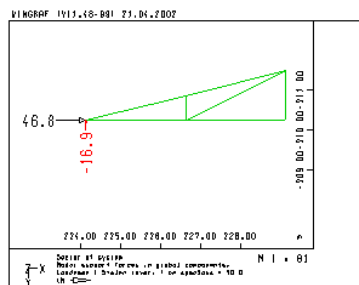

The group of tools:



is used for selective disposal of the structure elements.

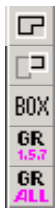

- All structural elements are shown
- Only elements in the selection frame are shown
- A dialogue box to enter precisely the coordinates of the selection frame
- Only elements that belong to a group are shown
- Elements from all groups are shown

Repeating the procedure previously described for the left support, drawings for the remaining reactions of the supports for the three load cases are created. Initially new drawing is inserted. Because the new drawing has the same content as the previous, with the help of the icon:



Structure limits

all drawing elements are displayed, and after that the command:



Box

is used to draw the frame to select the elements from the right support.

Thus, gradually adding drawings in the book one by one, all reactions in the supports are represented for the three load cases.

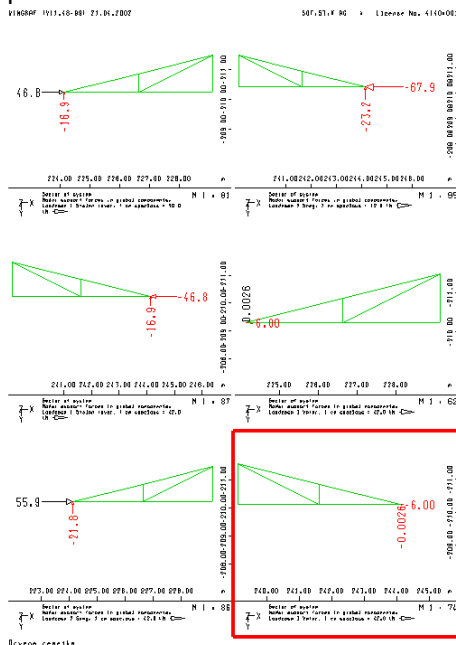

At last, new sheets are added where deformations and forces of the structural elements are shown.

Insert new sheet and format it so as to show two drawings on page height. Drawings appertain to the *Results* group. Using the icon, from the menu



ICON: Draw Results
MENU: Select → Draw Results...

a dialogue box is called up

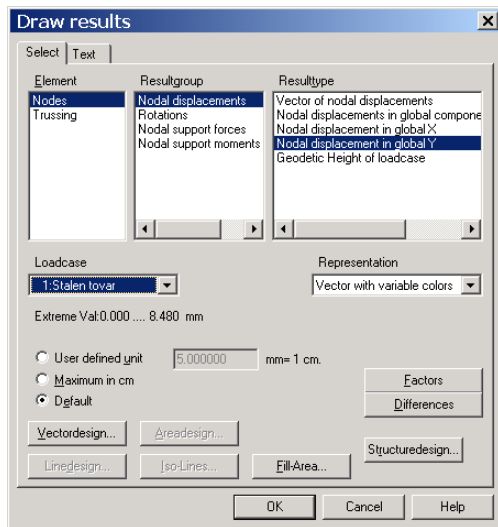

where following options are selected:

Element	Nodes
Resultgroup	Nodal displacements
Resultype	Nodal displacement in global Y
Loadcase	1:Stalen tovar
Representation	Vector with variable colors

The same effect can be achieved thru *Result* type operating area by selecting the option *Nodal displacements in global Y*.

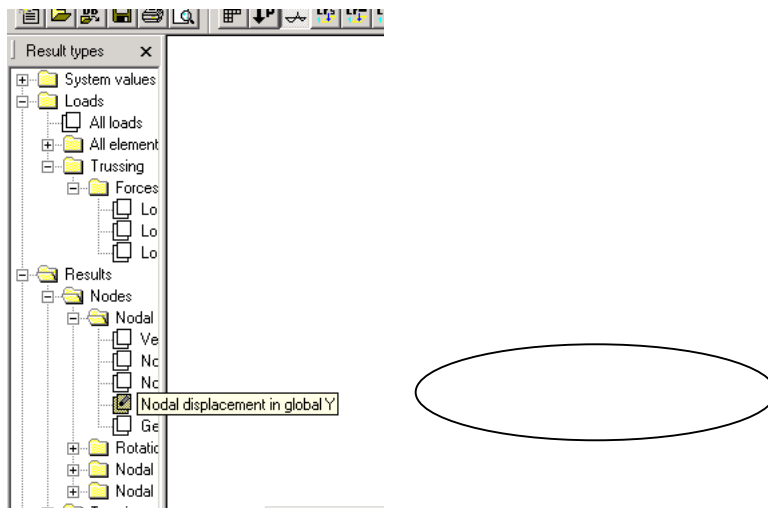

Node displacements are represented on the drawing in the global Y-axis direction. Also a legend is shown with different colors which represent displacement values.

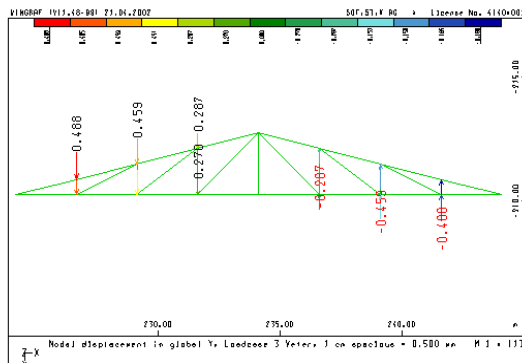

To display the forces, you should insert new drawing in the page and select:

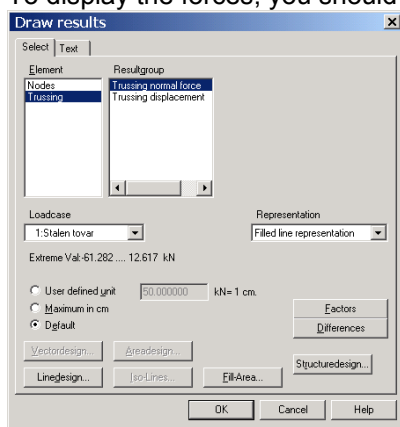

Element Trussing
 Resultgroup Trussing normal forces
 Resultype Filled line representation
 Loadcase 1:Stalen tovar
 Representation Vector with variable colors

The final configuration is shown in the following picture:

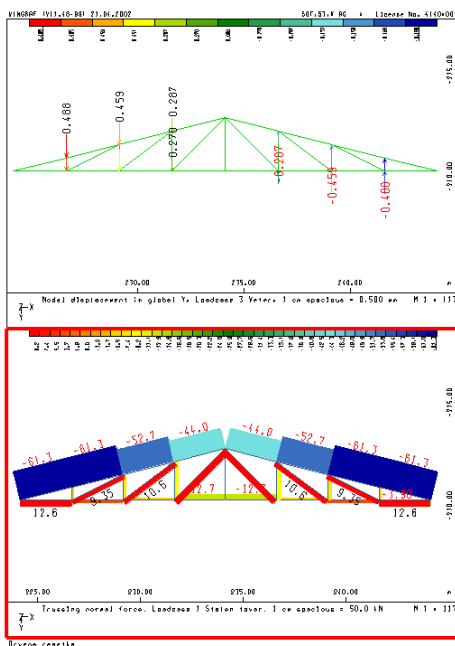

The last two pages will be created simultaneously. Before activating the command for creating new sheet, click on the drawing with the displacements. Thereby a drawing is active.

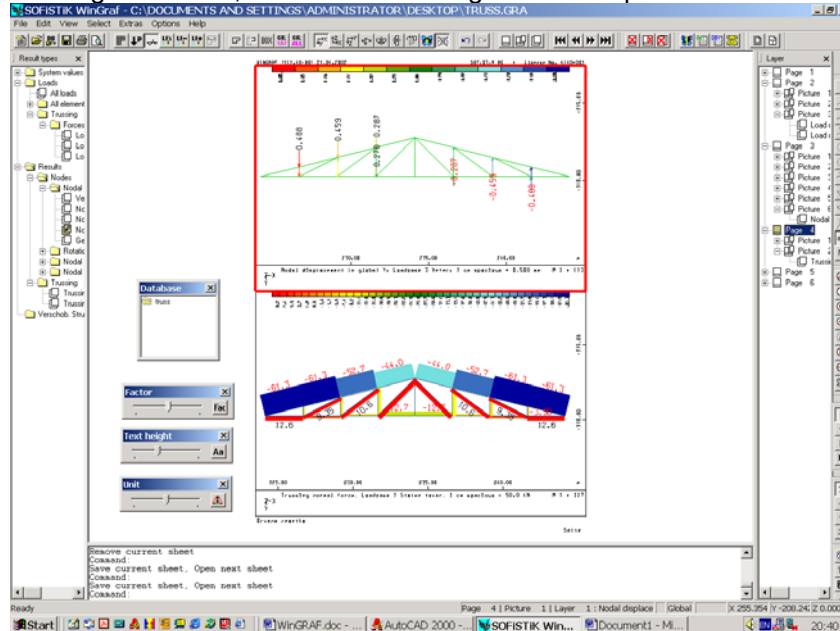

Click twice on the command *New Sheet*.



ICON: New Sheet
MENU: Edit→New Sheet

Insert two new sheets in the drawing book, in which by assumption, the last active drawing is inserted.

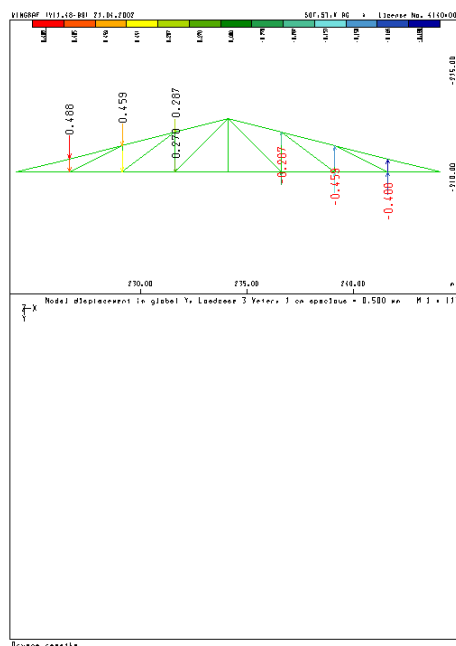

With the icon:



Select loadcase

choose a load case in where displacements are drawn,

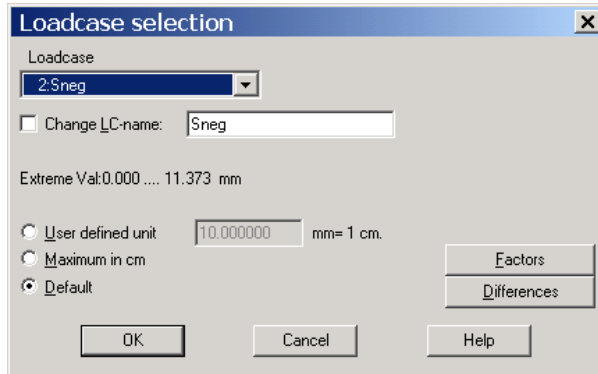

regarding the current example it is *Loadcase 2 Sneg*.

If you have to select the next load case, use the icon:



Select Next Ic

namely, for the last load case use the icon:



Select Former Ic

A new drawing is inserted in the sheet. As content, the drawing has the deformations created in the previous drawing.

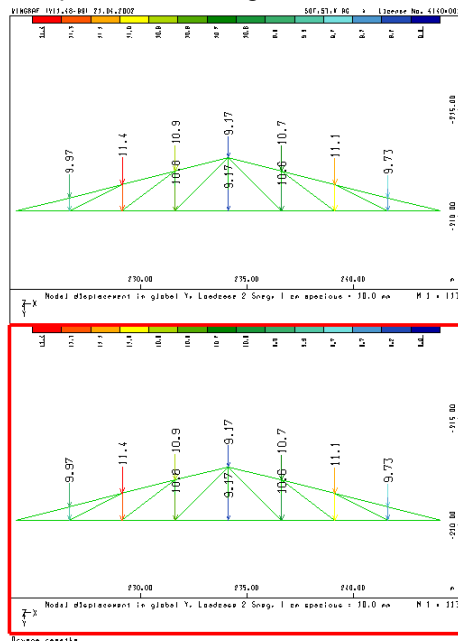

Now, activate the command:



ICON: Draw Results
MENU: Select → Draw Results...

and select a new type of results:

Element Trussing
Resultgroup Trussing normal forces
Resulttype Filed line representation
Loadcase 2:Sneg
Representation Vector with variable colors

WinGRAF automatically changes the drawing content.

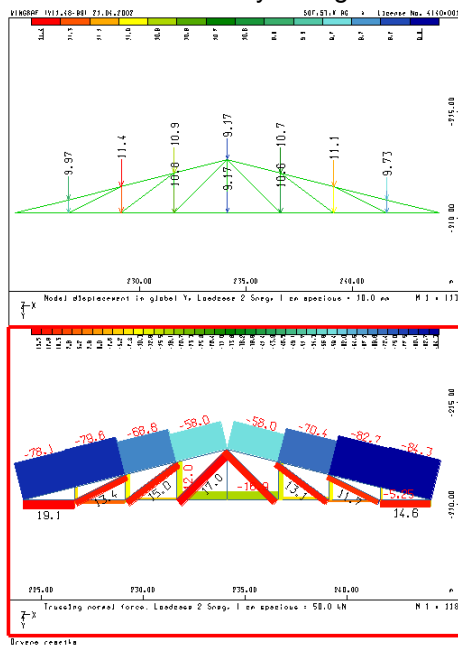

Similarly drawings on page 6 are created, and represent the deformations and forces from the *Veter* load case.

The drawing book contents can be listed using the following group of icons:



- Shows the first page
- Shows the previous page
- Shows the next page
- Shows the last page

Similar slide bars are used to list the pictures:



and layers



The following group of icons:



are used to delete a page, drawing or layer.



Deletes a page



Deletes a drawing



Deletes a layer

Representation of the structure in different projection is performed with the following group icons:



Displays a structure projection in XY plane



Displays a structure projection in XZ plane



Displays a structure projection in YZ plane



Displays axonometric projection of a structure



Commits mirror reflection around vertical axis



Commits mirror reflection around horizontal axis



Commits drawing rotation for 90°



Activates the *Animator* where structure outlook is allocated. This viewpoint is transferred in *WinGRAF*



Turns off the perspective view of a structure

The drawing book is saved on the disk using the classic *Windows* command *Save as....* The extension of these files is *.GRA*.

4. Example 1 : Steel Hall

4.1 HALL DESCRIPTION

The structure of the steel hall is designed from 8 steel frames placed on 10 meter mutual distance. The frames are composed of 3 bays with bay width 12+16+12 meters. The end columns are 6 meter high and the center of the frame is 8 meter high.

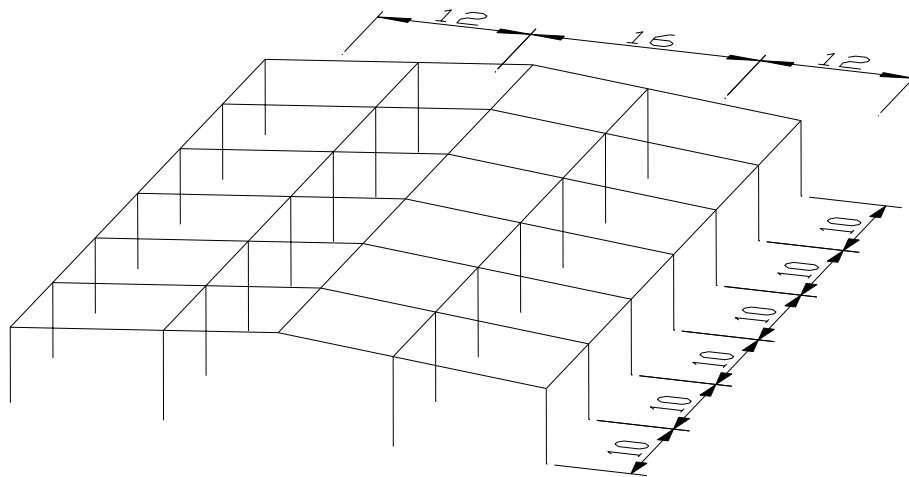

4.2 AutoCAD PREPARATIONS

The whole structure is drawn as 3D model. The formwork plan of the structure is represented in x-y plane. The frames are spreading in X direction (transverse direction) and the positive Z direction is vertically upward. It is desirable to use layers for drawing the structure. In order to eliminate eventual mistakes, all structural elements should be visible and easy to select. Text lines, dimension lines and any other auxiliary lines can interrupt when selecting the elements. Therefore it is usual such elements of the drawing to be placed on separate layers. Every designer has its own work style, so there should not be strict rules in organizing the drawing. One practical method when organizing the drawing is using three viewports.

Menu: AutoCAD→View→ Viewports→3 Viewports

Command: `_vports`

Enter an option [Save/Restore/Delete/Join/Single/?/2/3/4] <3>: `_3`

Enter a configuration option [Horizontal/Vertical/Above/Below/Left/Right]

<Right>: `Left`

Before start of the design process, it is required all layers without structural elements to be closed. The drawing is saved by file name: CELICNA HALA SOFiPLUS.DWG.

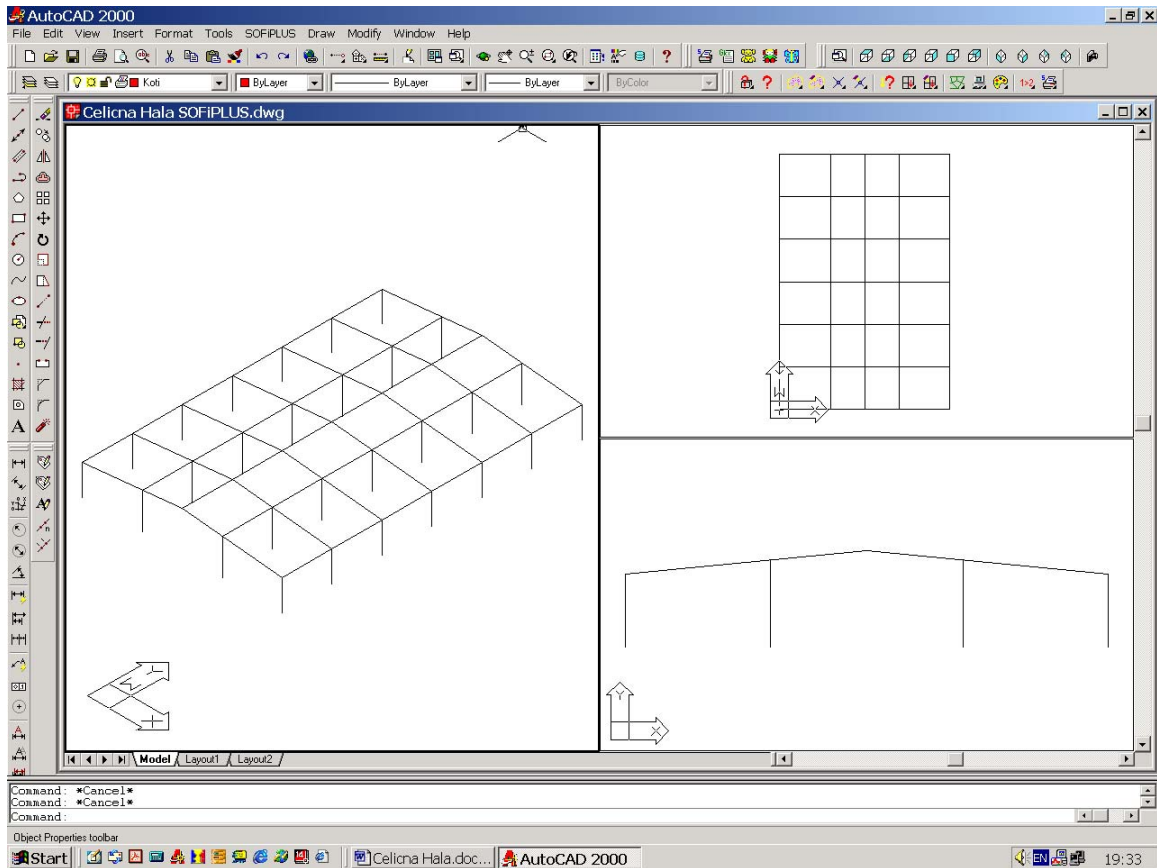

4.3 STRUCTURAL SYSTEM

The steel hall will be treated as spatial structure. The analysis will be performed according EuroCode (EC 2). Structural system is called up by:



ICON: SOFiPLUS
 MENU: SOFiPLUS→Structural system...
 Command: SOF_GSYSMOD

In the dialogue box Data Base Description and Choice

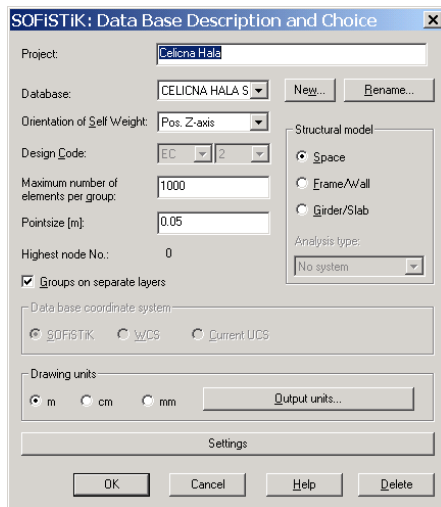

enter the following parameters for the data base:

Project	Celicna hala
Database	CELICNA HALA SOFiPLUS
Orientation of Self Weight:	Pos. Z axis (Direction of the self weight is in Z direction)
Maximum number of element per group	1000 (In frame systems usually the number of elements divided in groups are small)
Point size	0.05
Structural mode	Space
Database coordinate system	SOFiSTiK (Positive orientation of Z axis is vice versa direction of the Z axis defined by WCS in AutoCAD)
Drawing units	m

Data base is automatically created under the name of the drawing: CELICNA HALA SOFiPLUS.

4.4 MATERIAL

Structural elements of the hall are made from standard steel.



ICON: Material
MENU: SOFiPLUS→Defined model→Material
Command: SOF_GSYMATE

4.4.1

The dialogue box on the screen shows predefined materials which are not taken under consideration in this example.

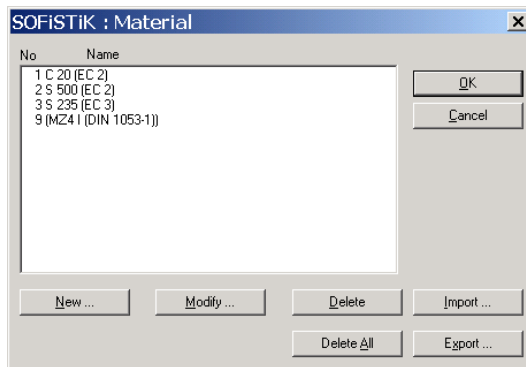

With the button Delete All, all materials are deleted. By clicking New... button, new dialogue box is opened where from the following options are selected:

Type (EC 2) Structural Steel
Classification 510

Because it is standard material it is not necessary to activate other buttons (Property, . . .) in order to adjust other material properties.

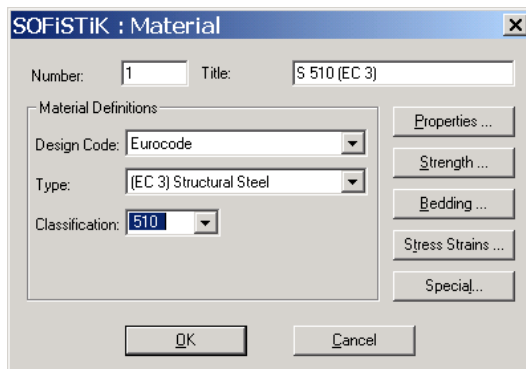

4.5 CROSS SECTIONS

Cross sections of the structural elements are presented in the following table:

Columns	2 □ 30
Beams	HEA 40
Wind bracing	



ICON: Cross Section
MENU: SOFIPLUS→Defined model→Cross Section
Command: SOF_GQUER

In the beginning the list of cross sections is empty. Gradually with the button New ... the cross sections used in the example are added in the model. It is not problem to define other cross sections if needed during the design process.

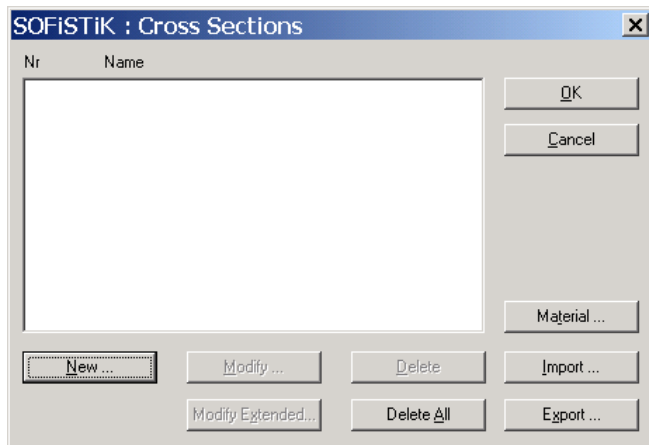

From the group of standard cross sections Rolled steel is selected.

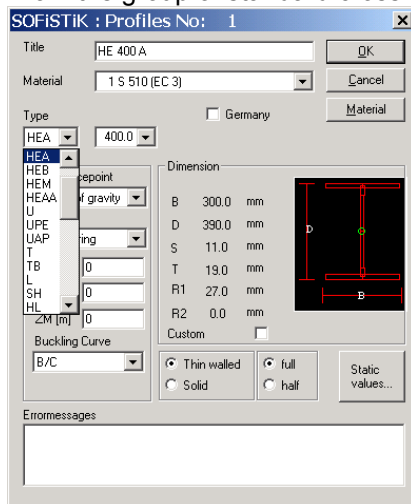

In the combo box Type select HEA and 400.

The second type is rectangular cross section which is contained by 2 [] profiles. Repeat the action for defining new profile.

New→Rolled Steel

Now, select:

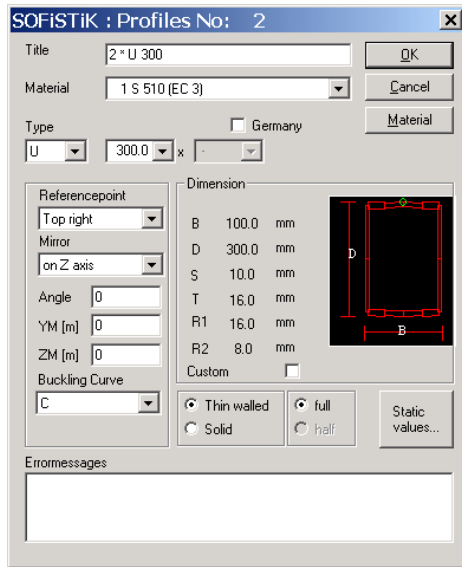

Type→U→300

In order to achieve rectangular profile, the sketch should be mirrored around Z axis (vertical axis). Place:

Reference point→Top right

Mirror→on Z axis

The results can be previewed in the Preview window. If needed, separation of the profiles can be accomplished by declaring YM and ZM values. The cross section can be rotated by the Textbox - Angle.

The third profile is channel with the following geometry:

Diameter→51 mm and Wall-thickness→2.0 mm

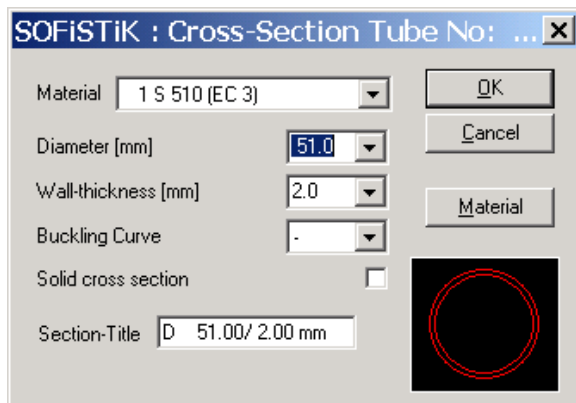

The list of the cross sections has the final form:

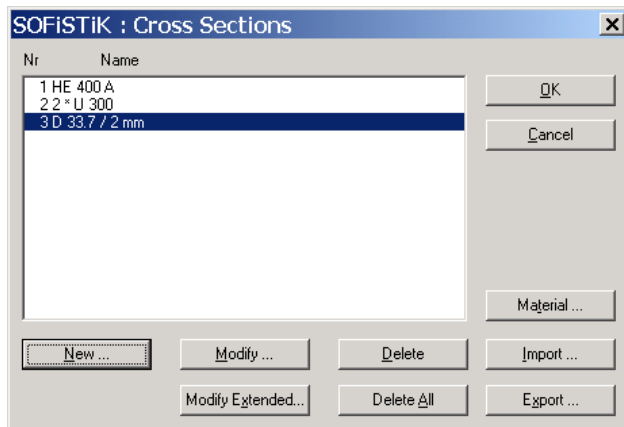

CREATING OF STRUCTURAL ELEMENTS

At first columns are to be created. Columns are beam elements. They can be created with:



ICON: Beam element
 MENU: SOFiPLUS→Create finite element→Beam element
 Command: SOF_G

This method for creating columns is very unpractical. There are a lot of columns and each has to be created separately. In such cases more efficient to use is the function Generate with objects.



ICON: Generate With Objects
 MENU: SOFiPLUS→Generate→With Objects
 Command: SOF_G

This opens dialogue box where the type of the elements which will be created with the following command, are to be selected. (in the example Beam). Minimal edge length of the elements can be defined if some elements from the group which is selecting, with length smaller than defined, has to be excluded. Number of the group must be indicated if the elements which are to be created has to be assembled in separate group.

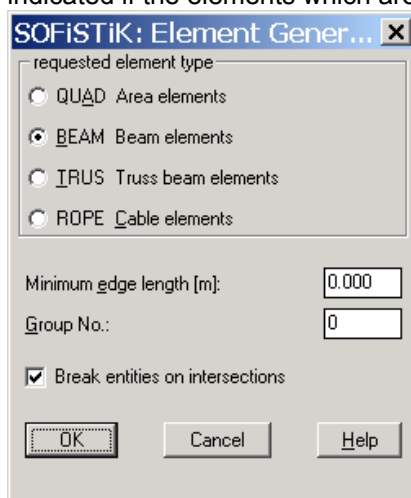

By using Crossing Windows, all columns from the frames are selected. (Lower right viewport is used).

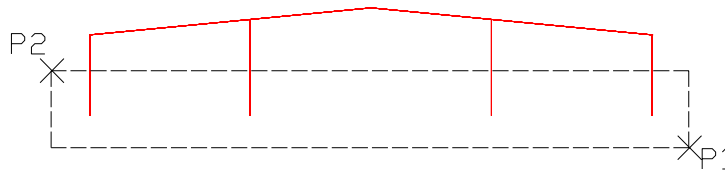

Command:
 Select objects: Specify opposite corner: 28 found
 (use Crossing Windows, P1 – P2)
 Select objects: **Return**

Searching intersections
 Treating partial-lines ...
 Making Elements ...
 First Beam No.<1>: **Return** (predefined element number 1 is accepted)
 Section number<1>: 2 (number of the section is 2)

Creation of the beams is similar. Initiate again the command: Generate With Objects.

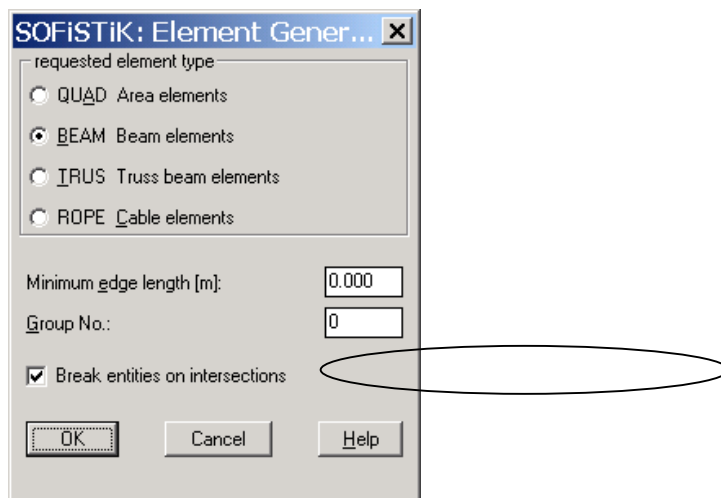

Make sure Break entities on intersection is checked. Beams are drawn by continuous lines. In the intersection points, node points should be inserted and elements are supposed to be created between intersecting point of the lines.
 Use Window to select the lines.

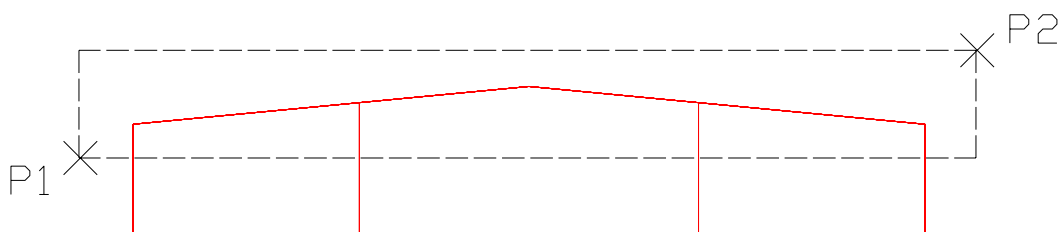

Command:
 Select objects: Specify opposite corner: 72 found
 Select objects: **Return**

Searching intersections

Treating partial-lines ...

Making Elements ...-

First Beam No.<29>: **Return** (predefined element number 29 is accepted)

Section number<2>: 1 (number of the section is 2)

Wind bracings can be formed directly. They are made from diagonally crossed steel channels, positioned between the first and the second, and the last and the last by one frame. Because of great slenderness these elements can not resist pressure. Therefore in the model they are going to be represented by Cable elements.



ICON: Cable

MENU: SOFiPLUS→Create finite element→Cable

Command: SOF_G

Command:

Node NA (end+cen+nod+int+ext): (Click on the first node)

Node NE (end+cen+nod+int+ext): (Click on the second node)

Section number<1> or [Prestress force]: 3

First Cable No.<1>:

Node NA (end+cen+nod+int+ext): (continue entering other elements)

For easy defining cables, it is possible to draw auxiliary lines which will be converted to structural elements with Generate With Object command.

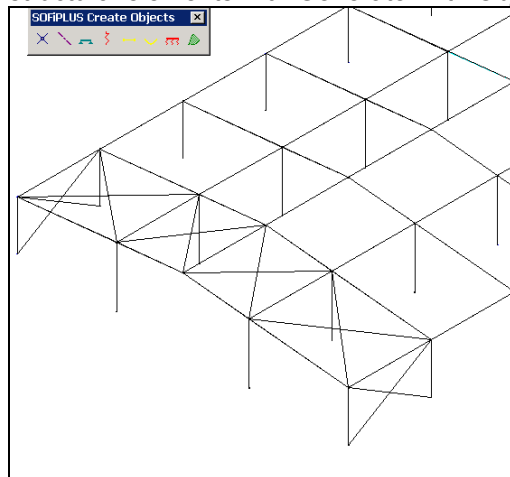

It must be taken care about mutual passing of each diagonals of wind bracings. They do not form common intersection point.

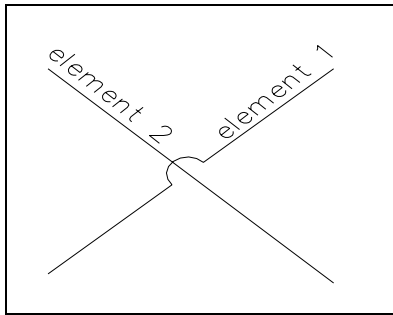

Make sure Break entities on intersection is not selected.

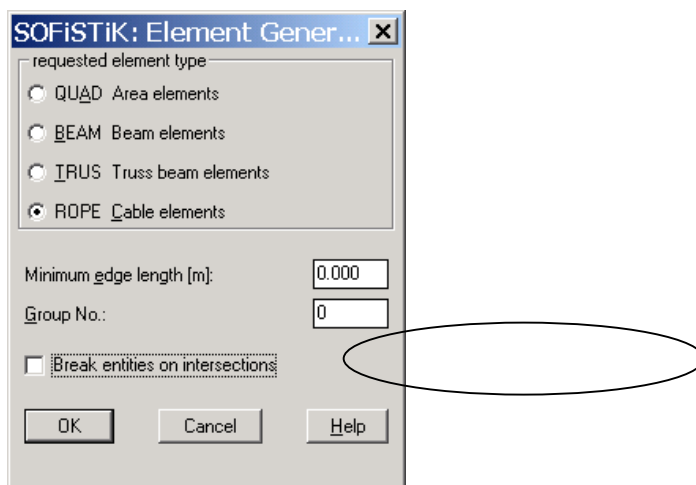

You can now select all elements of the wind bracings. It is possible to use all Viewports and all AutoCAD methods for selecting.

Select objects: (Select all diagonal elements)

..

Treating partial-lines ...

Making Elements ...

Section number<3> or [Prestress force]: **Return**

(Accept the offered number of the section)

First Cable No.<1>: **Return**

(Accept the offered number for starting number of cables to be generated)

Diagonal element in the last bay are exactly the same as diagonal elements from the first bay. Thus, AutoCAD command Copy will be used to generate these elements.

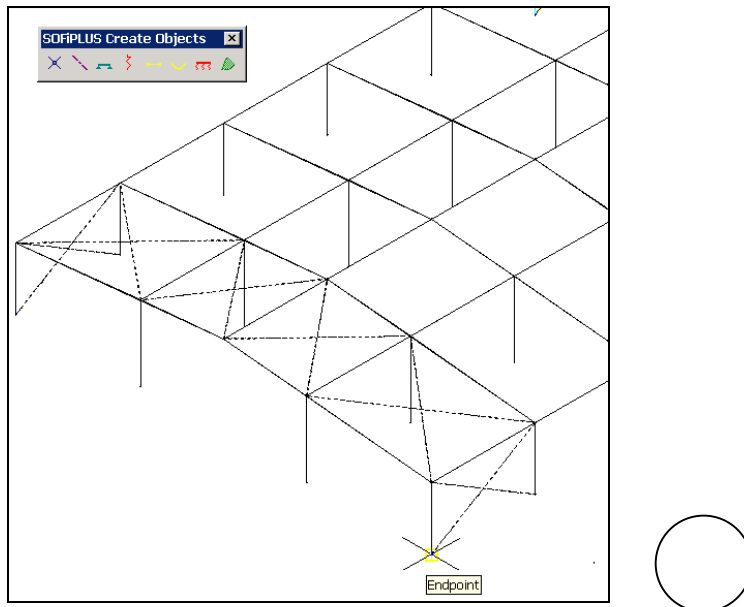

After activating Copy command, all diagonal elements from the wind bracing are selected. As a Base point is used the lower point of the column. The copying procedure starts from the column of the last by one row.

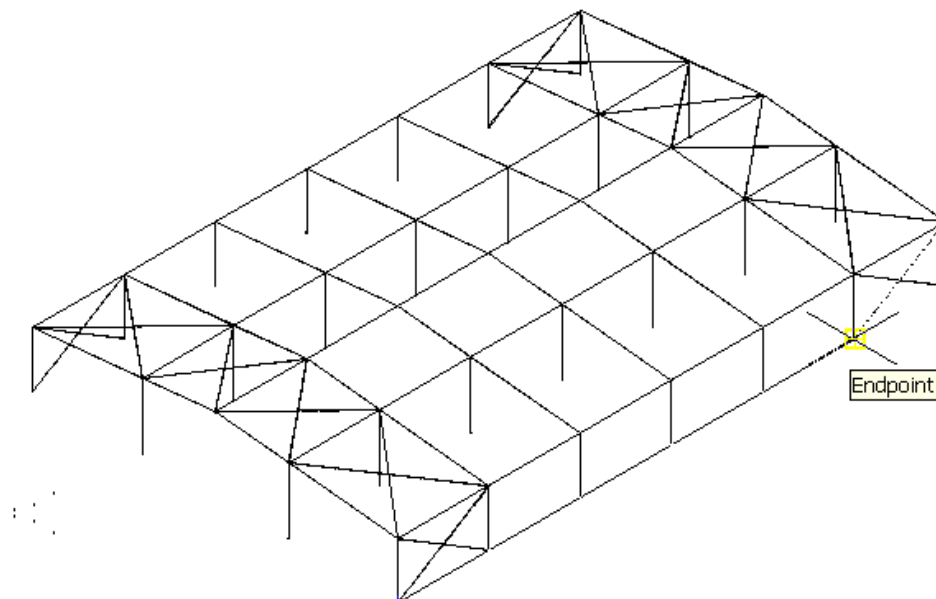

Systems in which AutoCAD tools: Copy, Array and others are used should be checked. It is desirable to perform structure check after generation process, even if the standard way of generating structural elements is used. With this control all mistakes made in the method, like folding over of two points or accidental deletion of nodes, are eliminated. Start the command for transferring data into the analysis database.



ICON: SOFiPLUS→Export
 MENU: SOFiPLUS→Analysis Data Base (CDB)→Export(..
 Command: SOF_GENFOUT

Select the option Check run (no output) in the dialogue box.

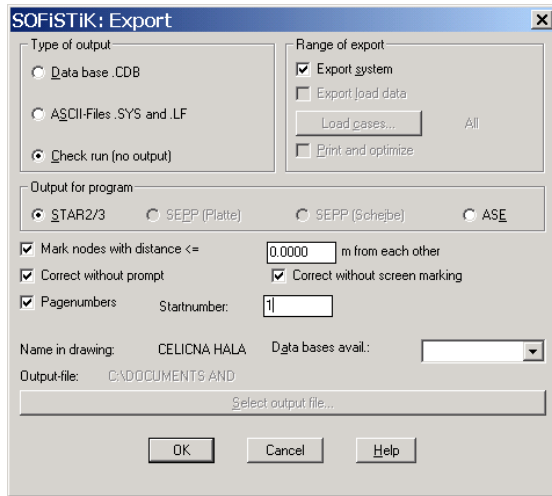

It is sometimes required to repeat this procedure with the purpose of eliminating the mistakes.

4.6 ORIENTATION OF ELEMENTS

Beam elements have local co-ordinate system x, y, z . Starting point NA and ending point NE define the positive direction of the X-axis.

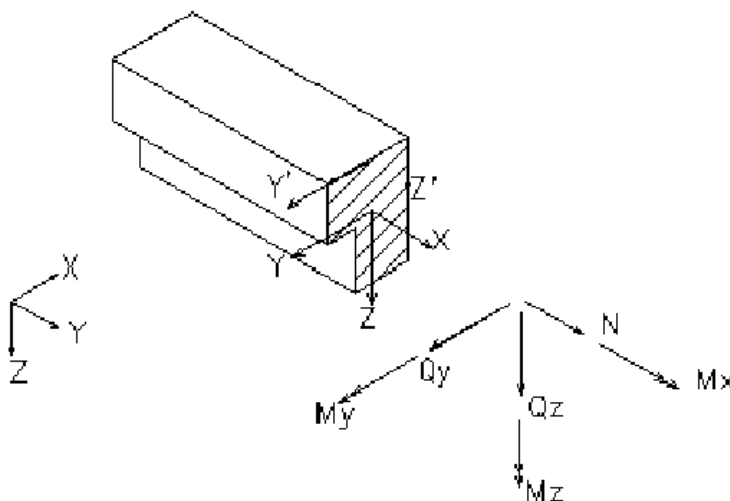

In case of plane frame structure, the direction of Y-axis is defined so bending always happens around that axis.

Depending of the orientation of the other two axis, three cases are distinctive:

1. Plane frame

The structure lies in the global XY plane. Local Y-axis of the beam is parallel to global Z-axis but has opposite direction. Local Z-axis is perpendicular to beam axis and oriented on right of the beam direction.

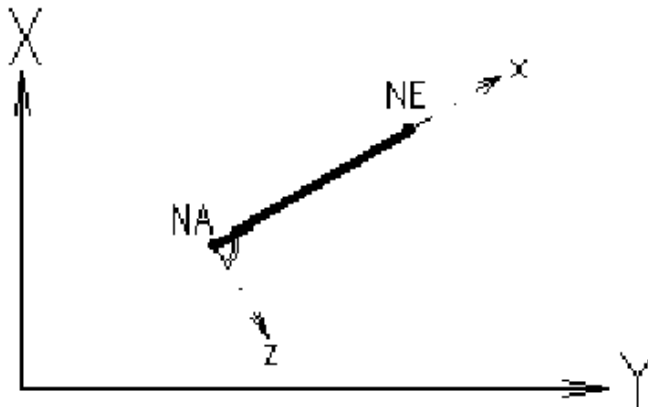

2. Plane grid

The structure lies in global XY plane. Local Z-axis of the beam is parallel to global Z-axis. Local Y-axis of the beam is parallel to beam axis and oriented on right of the beam direction.

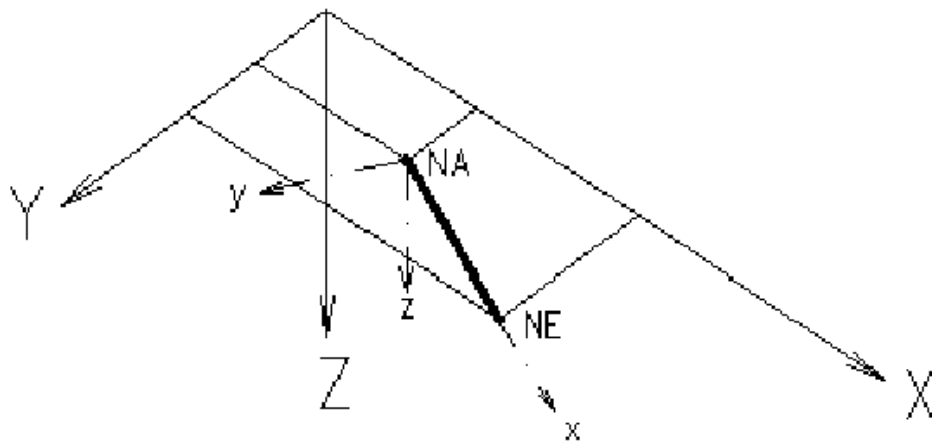

3. Space system

In three dimensional systems orientation of the local Y-axis must be defined by the user. Local Z-axis is perpendicular to local X and Y axes. It's direction is determined according right hand rule.

These cases can occur:

Local Y-axis is parallel to global XY plane and perpendicular to beam axis, and on the right of beam direction. This is independent from gravity direction and always in clock-wise direction in respect to global Z-axis.

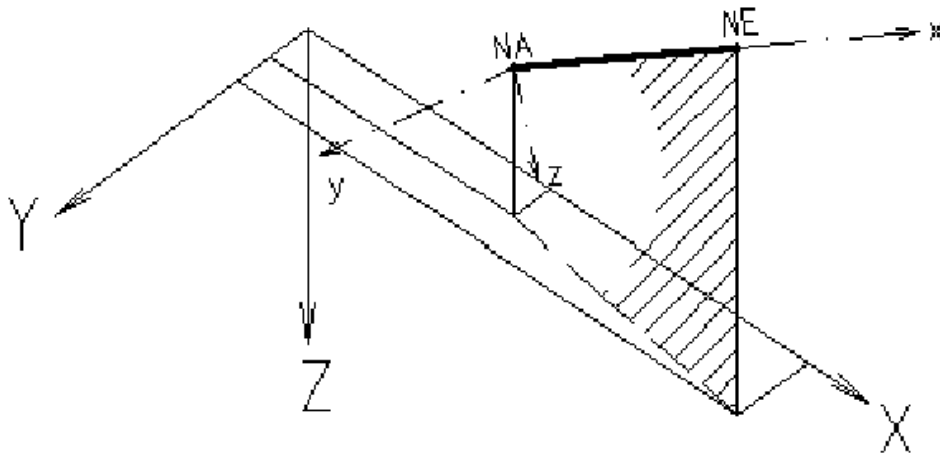

Beam axis is parallel to global Z-axis, so the local Z-axis is parallel to global Y-axis.

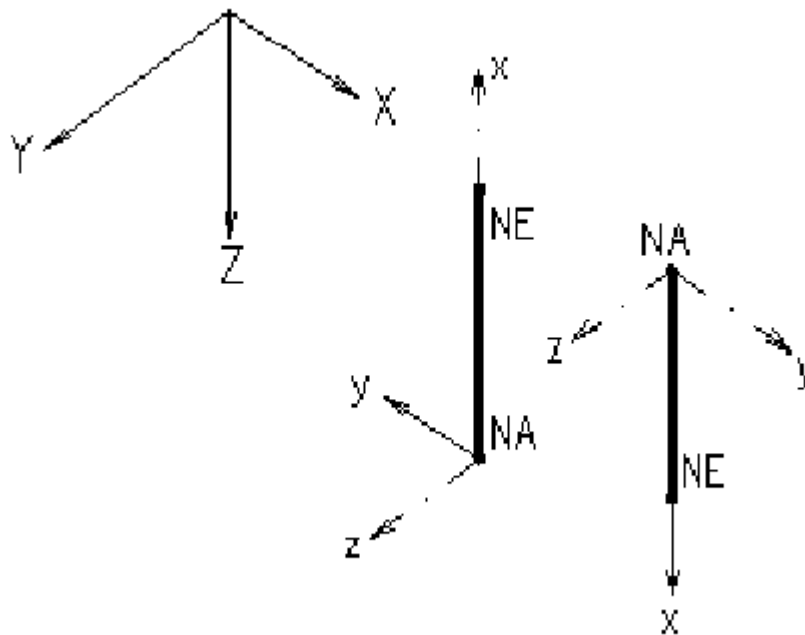

Beam is freely oriented in the space.
In such cases the designer should be particularly careful. It is recommended to create visual control of the beam orientation.

4.7 BEAM ORIENTATION CONTROL

SOFiSTiK offers efficient way to control the beam orientation.



ICON: SOFiPLUS→Display Beam Coordinate Systems

MENU: SOFiPLUS→Visualize→ Display Beam Coord. System

Command: SOF_G

Command:

Factor<0.0000> or [SEttings/STart/Mid/End]: M

Elements to be visualize (RETURN=All)

Select objects: (select the elements in which local coordinate systems are to be shown)

In the first line of the command it is required to select a point where local coordinate system is to be placed.

Settings – select color and size of the arrows which will represent coordinate system

Start – coordinate system is placed in the beginning point of beam (NA)

Mid - coordinate system is positioned in the middle of beam (NA)

End - coordinate system is positioned in the ending point of beam (NE)

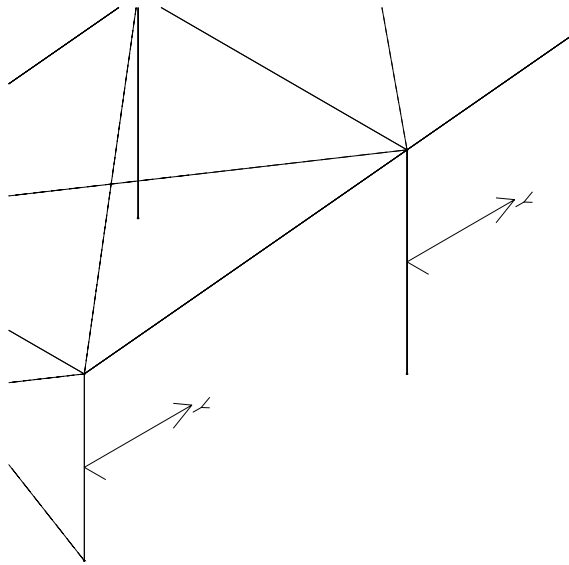

In the this example local coordinate system of the columns is being controlled. After selection, in the center of the columns local coordinate system (Y-axis) is shown. Local coordinates of the columns are compared to coordinates considered when cross sections are defined.

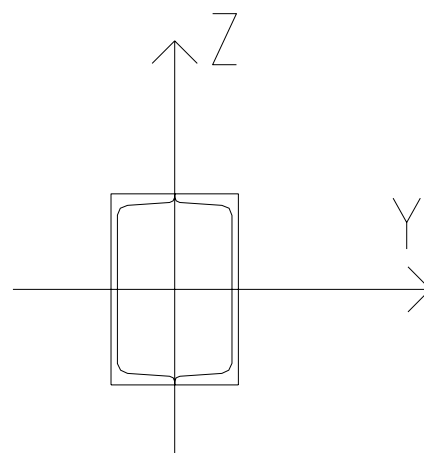

From the results of the performed control it is obvious that greater moment of inertia is around Y-axis. This position of the section performs bending of the elements from the frames around Z-axis, which is not correct.

With the intention of using greater bearing capacity of the section in the Z direction it is needed to rotate the section for 90^0 .



ICON: Cross Section
 MENU: SOFiPLUS→Defined model→Cross Section
 Command: SOF_GQUER

Select cross section 2 and click on Modify ...

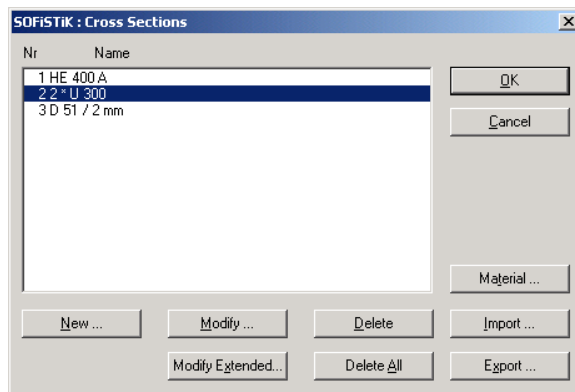

Change the angle value to 90.

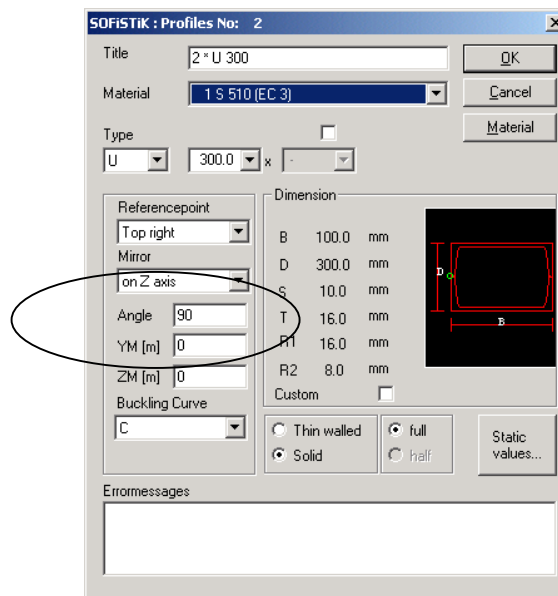

Visualization of the beam local coordinate systems shows that local axis of the beams folds over Y-axis of the cross section. Bending is around the axis with greater moment of inertia. Beams are correctly oriented and there is no need for changing cross section orientation.

4.8 RESTRAINTS

Supports of the steel hall members are fixed. In order to apply the restraints in which structural members are supported, modification of the nodes is required.

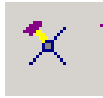

ICON: Modify node
 MENU: SOFiPLUS→Modify finite element→Node
 Command: **SOF_GNOTMOD**

Select the nodal joints which will be restrained from displacement.

Command:

Select option <Select objects>[Select objects/Enter number/Pick nodes]: S

Accept the offered option. <Select objects>.

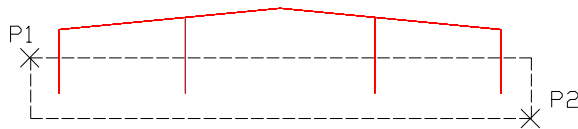

After selecting the nodes, in the opened dialogue box check the boxes for constrained degrees of freedom.

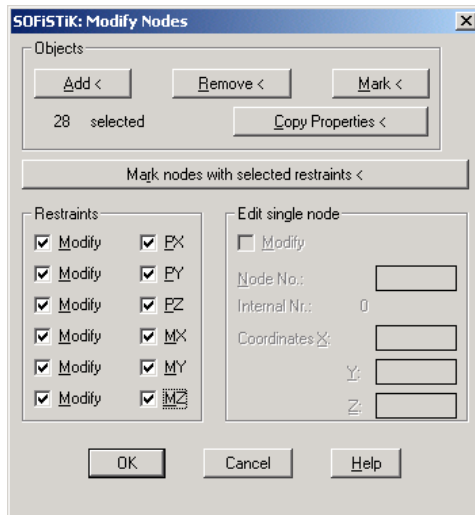

4.9 VISUALIZATION OF THE RESTRAINTS

For the purpose of showing the restraints of the structure, visualization is performed.



ICON: Display restraints
 MENU: SOFiPLUS→Visualize→Restraint
 Command: **SOF_GFEST**

When asked

Einstellungen? [Ja/<Nein>]: J

answer with N (nein) and the predefined properties of the visualization are accepted.

4.10 LOADING

All loading cases are defined. Load distribution depends on the type of the roofing structure and curtain walls. In this example load analysis is not performed, so predefined loads are accepted:

Roof weight	0.10 kN/m ²
Snow weight	0.75 kN/m ²
Wind pressure	1.00 kN/m ²

Wind suction 0.50 kN/m²



ICON: Loadcase Manager
 MENI: SOFiPLUS→Loadcase Manager
 Command: SOF_GLFMOD

In the beginning the list of load cases is empty. Clicking on Button New... enter three load cases.

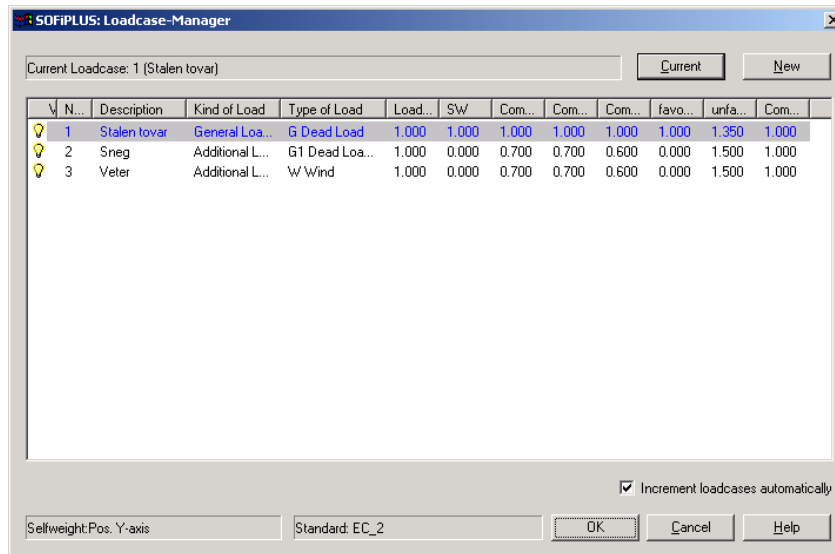

4.10.1 Dead load

In this example loads which act on the roof are directly transferred on the frames. By multiplying the uniformly distributed load with the frame span (for middle frames), or half the frame span (for ending frames) equivalent frame loads are the result. Dead load is placed as current load case.



ICON: Beam load
 MENI: SOFiPLUS→Create loads→Beam loads
 Command: SOF_GXLAS

Command:

Select option <Select objects>[Select objects/Enter number/Pick Beam]: **Return**

Select objects: (select the internal beams)

Select objects: **Return**

Distance from beam start<0.0000>: **Return**

Load end distance from beam end<0.0000> or [Further-beam/Point load/Load length]: **F**

(F- load also acts on the next beam)

next beam (nea):

Load end distance from beam end<0.0000> or [Further-beam]:

Load type [Load/Moment/Pre-displacement/Temperature]: **I**

Load [PS/P1/P2/PX/PY/PZ/PXP/PYP/PZP]: **PZ**

(Roof load acts on the downward beam length-global Z axis)

Load in kN or [Variable load]: **1.00**

(0.10kN/m² * 10m = 1.00 kN/m')

Select option <Select objects>[Select objects/Enter number/Pick Beam]:

(continue with entering loads on ending beams with value 0.5 kN/m')

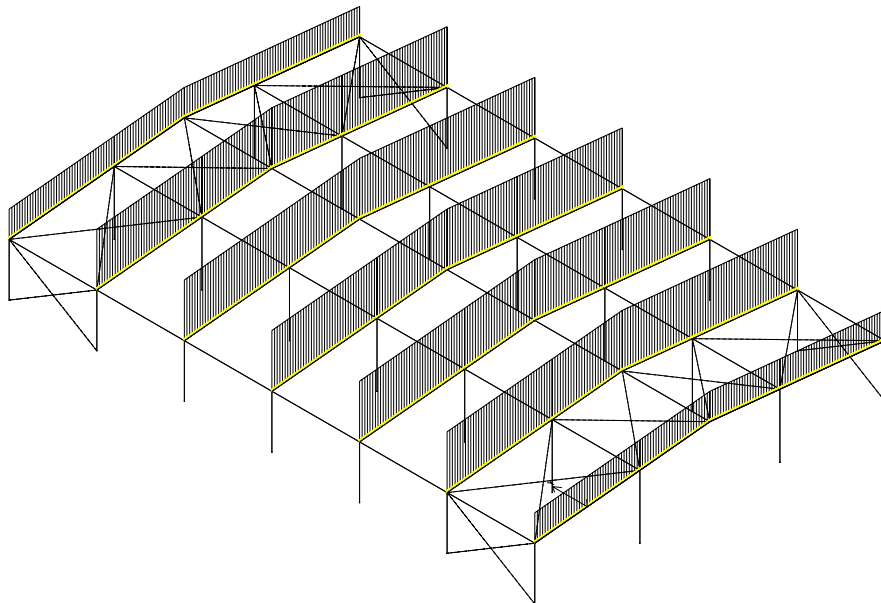

4.10.2 Snow load

Before entering next loads, it is suggested to make all other loads invisible. Activate AutoCAD function Layer Property Manager, and switch off the layer named XV__S001_HALA1. It is possible to use SOFiPLUS tools for switching off certain load cases.

SOFiPLUS→Vizualize→Delete vizualization

Select &Loads and Switch Off

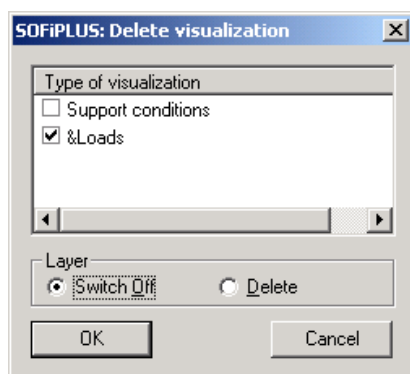

which turns off all load cases from the viewing point. The procedure for entering snow load is the same as entering dead load.

The difference is that snow acts on horizontal plane. Label for this load is: PZP

Load [PS/P1/P2/PX/PY/PZ/PXP/PYP/PZP]: **PZP**

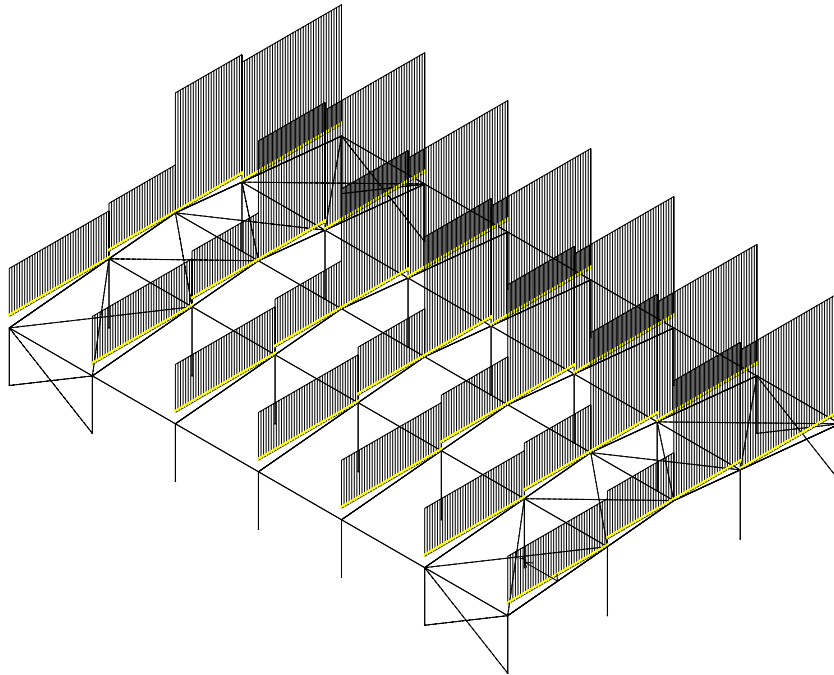

In this example asymmetric snow load is taken under consideration.

4.10.3 Wind load

Lateral wind load is studied. In this example wind acts only on the beams. The wind direction is global Y-axis.

Load [PS/P1/P2/PX/PY/PZ/XPX/PYP/PZP]: **PY**

Wind pressure is 6 kN/m' and wind sucking is 3 kN/m'.

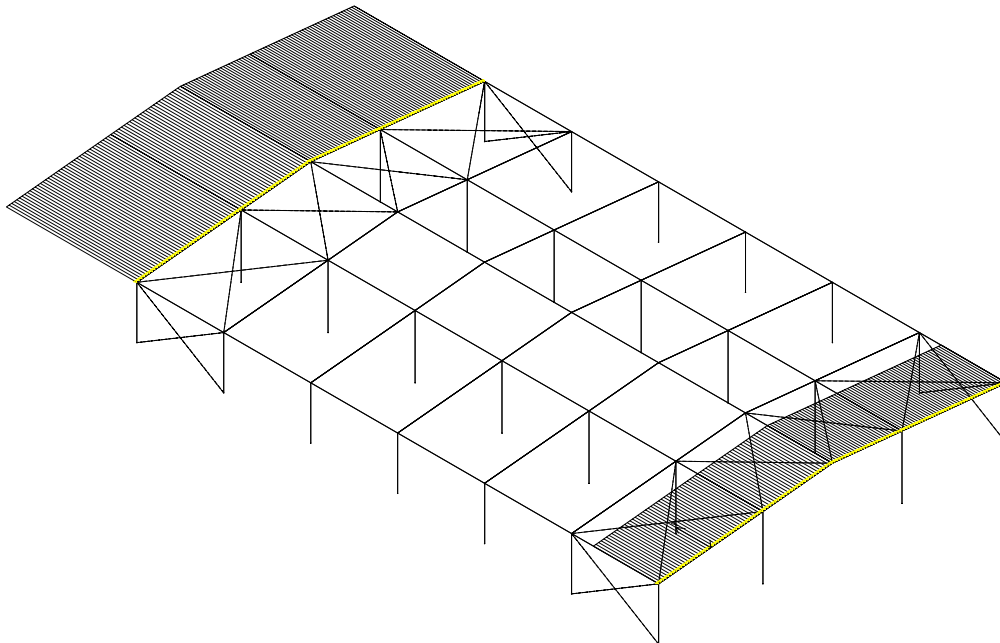

4.11 TRANSFERRING DATA INTO DATABASE

When the model of the structure is prepared and all load cases are entered, the data are transferred into analysis database.



ICON: SOFiPLUS→Export
 MENI: SOFiPLUS→Analysis Data Base (CDB)→Export(..
 Command: SOF_GENFOUT

Command Export transfers all the data which were saved within a drawing into analysis database.

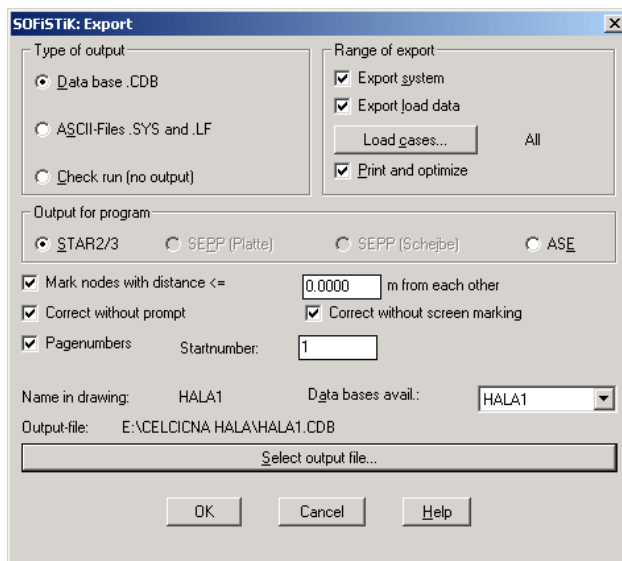

By accepting the offered options, preprocessing process finishes.

4.12 STRUCTURAL ANALYSIS

The analysis is made with the program WTED.



ICON: Edit (Win Ted)
 MENI: SOFiPLUS→Analysis ...
 Command: SOF_G

In the dialog box enter the file name for input: CELICNA HALA SOFiPLUS.DAT.

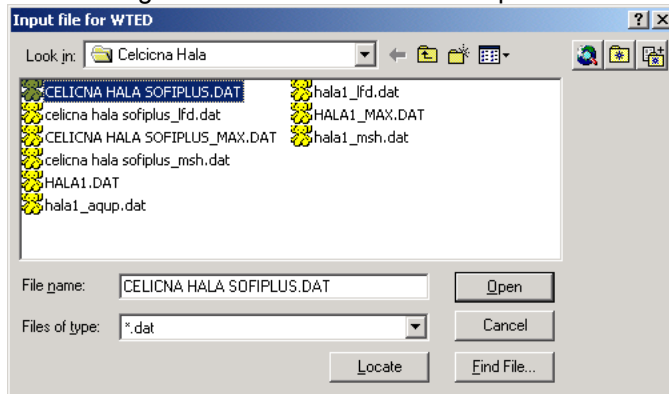

Working area of the program WTED is displayed.

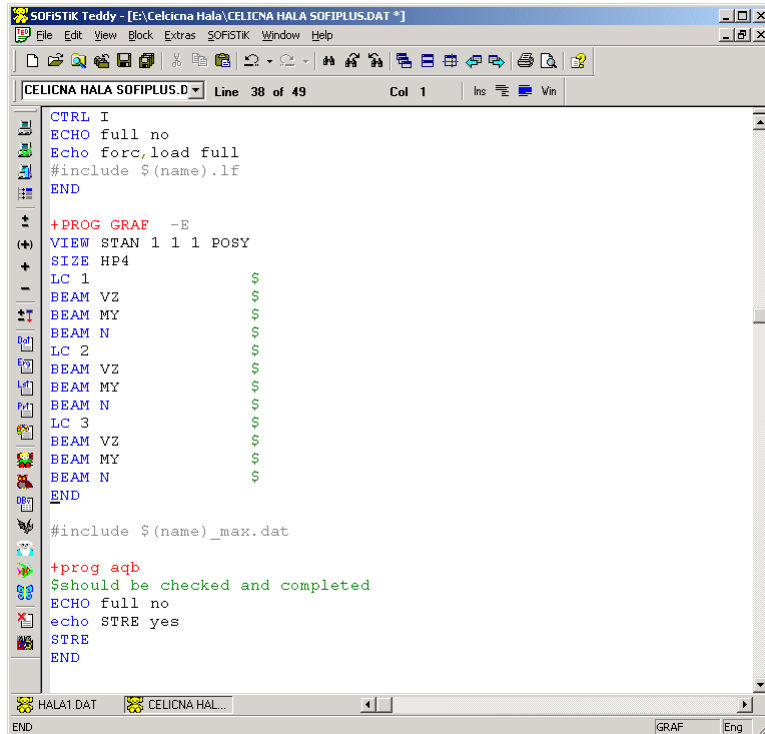

```

CTRL I
ECHO full no
ECHO forc,load full
#include $(name).lf
END

+PROG GRAF -E
VIEW STAN 1 1 1 POSY
SIZE HP4
LC 1
BEAM VZ
BEAM MY
BEAM N
LC 2
BEAM VZ
BEAM MY
BEAM N
LC 3
BEAM VZ
BEAM MY
BEAM N
END

#include $(name)_max.dat

+prog aqb
$should be checked and completed
ECHO full no
echo STRE yes
STRE
END

```

Modify module

+PROG GRAF

in order to output calculation results for three load cases. Some predefined modules which are sufficient for the current analysis are eliminated. (In this example MAXIMA and AQB)

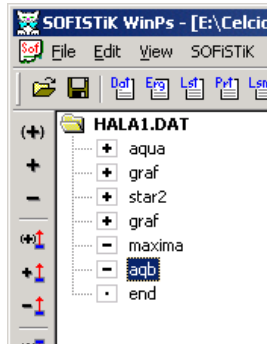

The control box from the analysis process shows that modules AQUA and GRAF are completed without errors and module STAR2 has warnings.

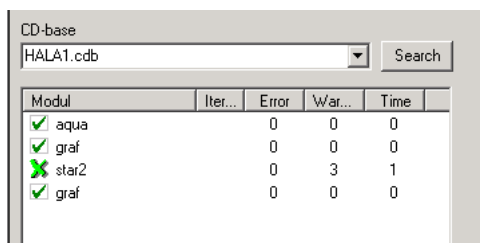

Modul	Iter...	Error	War...	Time
✓ aqua		0	0	0
✓ graf		0	0	0
✗ star2		0	3	1
✓ graf		0	0	0

This warnings should be carefully examined. To display SOFiSTiK messages, you should run Ursula program.



Ursula is used for creating output file, which contains text and graphical presentation of the results.

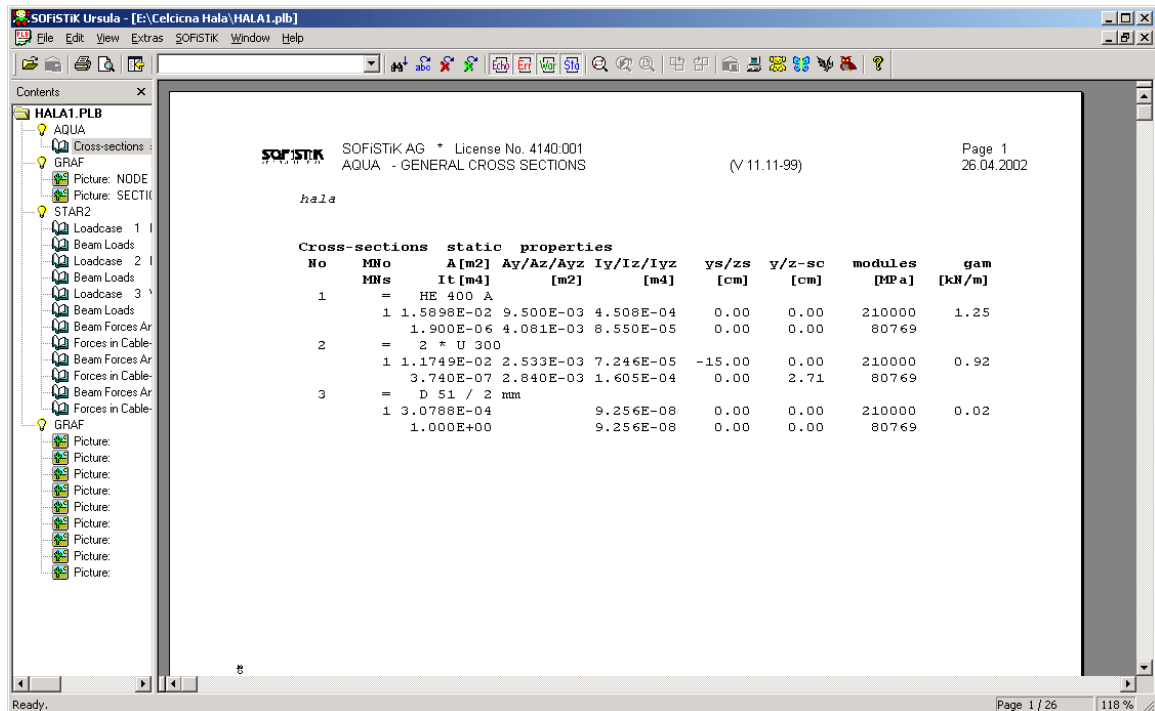

4.13 Tool



Search warning enables fast positioning of the warnings. In this example, warning message is:

```
+++++ warning no.      7 in program FEDE
System with SEIL elements without iteration yields false results !
When iteration not desired, please, use truss members of type FACH
----- New Page -----
```

This warning shows that cable elements are used for modeling the structure. When cable element are being used, analysis process must be iterative or cable elements should be replaced with truss elements.

4.14 EXPLANATION

In the first analysis, this program determines forces in the elements. If cable element is exposed to pressure it should be eliminated from the analysis (because of great slenderness cable elements cannot resist compressive stresses). The process should be repeated without participation of the compressed cable elements. It is iterative process executed in few cycles. In this example modifications are made in STAR2 module. Number of iterations are limited to 2.

CTRL II 5

Results from every iteration are requested.
ECHO STEP 1

```

PROG STAR2
HEAD WIND TO THE LEFT - WIND TO THE RIGHT
CTRL II 5
ECHO STEP 1
LC 1
NL 2 PX 10
END
CTRL II 5
ECHO STEP 1
LC 2
NL 3 PX -10
END

```

Depending on the structural system, EXECUTE activates few predefined modules. Detailed explanations about contents and functions of those modules are presented in their manual. For complete analysis process, some predefined functions and functions which have to be included in the analysis are explained.

4.14.1 +PROG AQUA

is for calculating geometrical properties of the cross sections. Static values can be also entered as well as dimensioning or stress check of the section. Predefined values in AQUA are:

```

+PROG AQUA -E urs:1
PAGE firs -1
ECHO full no; ECHO sect yes
END

```

PAGE - Control of Input/Output – Control of input/output data.

First – number of the first page, if negative page numbering is not performed.

Line – number of lines per page

LANO – output file language code

German
English
French
Spain

LANI – input file language code

UNIO – input file system units
UNII – output file system units

SOFiSTiK supports following system units:

- 0 =Standard units of SI-System
- 1 =General structural engineering (e.g. cm instead of m)
- 2 =Steel construction, SI-System (e.g. mm instead of m)
- 3 =Concrete bridge construction, SI-System (e.g. MN instead of kN)
- 4 =Foundations, SI-System (e.g. MN instead of kN)

- 5 =Hydrology
- 8 =Standard units of US-System
- 9 =General structural engineering in US-System
- 10 =Steel construction in US-System
- 11 =Concrete bridge construction in US-System
- 12 =Foundations in US-System

4.14.2 ECHO - Extent of Output

Member	Description	Type	Default
OPT		Text	FULL
	Material parameters	MAT	
	Cross section elements	SECT	
	Element references	REFP	
	Cross section values	SDEF	
	System statistics	SYST	
	Drawings characteristics	PICT	
	Integral method for equations	IEQ	
	Selection of all options	FULL	
VAL		Text	FULL
	No calculation/output	OFF	
	No output results	NO	
	Normal output results	YES	
	Extended output results	FULL	
	Extreme output results	EXTR	

By default SOFiSTiK offers:

ECHO full no; ECHO sect yes

which stands for generating output results only for cross section elements

Small correction in the input data is made in AQUA, in order to display results in English.

```
+PROG AQUA -E urs:1
```

```
PAGE firs -1 LANO 1
```

```
ECHO full no; ECHO sect yes
```

```
END
```

Output results presented in URSULA are:

hala

Cross-sections static properties

No	MNo	A [m ²]	Ay/Az/Ayz [m ²]	Iy/Iz/Iyz [m ⁴]	ys/zs [cm]	y/z-sc [cm]	modules [MPa]	gam [kN/m]
1	=	HE 400 A						
	1	1.5898E-02	9.500E-03	4.508E-04	0.00	0.00	210000	1.25
		1.900E-06	4.081E-03	8.550E-05	0.00	0.00	80769	
2	=	2 * U 300						
	1	1.1749E-02	2.533E-03	7.246E-05	-15.00	0.00	210000	0.92
		3.740E-07	2.840E-03	1.605E-04	0.00	2.71	80769	
3	=	D 51 / 2 mm						
	1	3.0788E-04		9.256E-08	0.00	0.00	210000	0.02
		1.000E+00		9.256E-08	0.00	0.00	80769	

4.14.3 + PROG GRAF

is used for graphical presentation of the structure and results. It is predefined to call up twice. In the first case graphical presentation of the structure is called up.

```
+PROG GRAF -E urs:2
VIEW STAN 1 1 1 POSZ
SIZE HP4
STRU 1 1
STRU sno
END
```

VIEW -View Specification

ÄÄÄÄÄÄÄÄ

Member	Description	Type	Default
TYPE	Element presentation	Text	angle
	View point (X, Y, Z)	STAN	
	View line	DIRE	
	Axonometric angle X, Y, Z	ANGL	
	Reduction factor X:Y:Z	SCAL	
X	Direction for TYPE (line view or angle or reduction)	-/degrees	0
Y		-/degrees	0
Z		-/degrees	0
AXIS	Orientation for STAN, DIRE and SCAL	Tekst	
	Positive x-axis downward	POSX	
	Positive y-axis downward	POSY	
	Positive z-axis downward	POSZ	
	Negative x-axis downward	NEGX	
	Negative y-axis downward	NEGY	
	Negative z-axis downward	NEGZ	
ROTA	Additional rotation in the drawing in clock-wise position	Degrees	0

In this example, predefined values for the view are:

```
VIEW STAN 1 1 1 POSZ
```

Which denotes view point with coordinates 1, 1, 1 and determines positive direction of Z-axis.

SIZE - Scale and Paper Size - Paper format for printed results is defined.

In this example, predefined paper format is A4.

SIZE HP4

STRU - Representation of Structure Values

Member	Description	Type	Default
NUME	Element presentation	-/Text	-
	Draw one element	-	
	Do not draw element	0	
	Element numbers	n	
	Group numbers	GRP	
	Material numbers	MNO	
	Cross section numbers	SNO	
	Cross section contours	SECT	
	Do not generate BRIC areas	SPAC	
	Accept BRIC areas	GLAZ	
	Contour areas only	CONT	
	Do not draw structure	NO	
NUMK	Draw node numbers	-	-
	Draw any element number	-	
	Do not draw numbers	0	
	Number of every n node	n	
	Number of supports	FIX	
	Extreme output results	EXTR	
OFFE	Beam element distance numbers	-	0
OFFK	Node numbers distance	-	4

Predefined values are:

STRU NUME 1 1

STRU sno

meaning creating of two drawings, one with node and element numbers and the other with cross section numbers. Node and element numbers start from 1

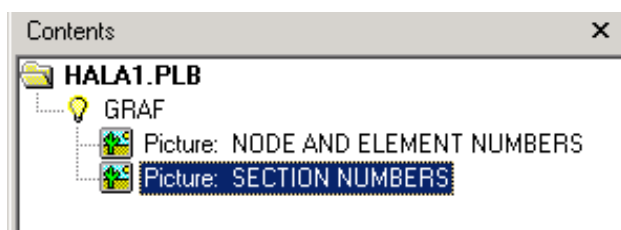

Lightning bulb before GRAF is used for turning GRAF on or off in the book for output results.

ICON



works by switching on/off. You can turn off certain drawings from the book with output results.

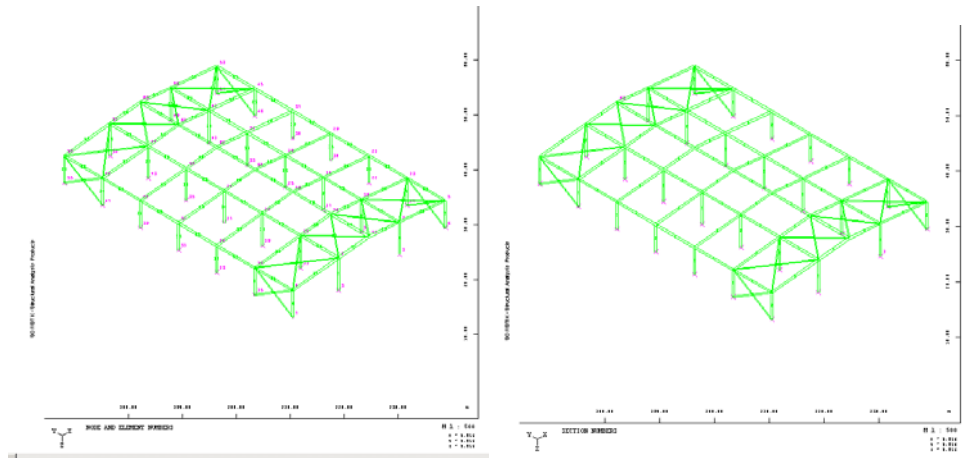

4.14.4 PROG STAR2 –

Module for static calculation of frame structures

Depending on input data, this program identifies three operating modules:

- load generation
- analysis
- restart

In this example loads are completely defined with SOFiPLUS. Eventually additional load cases can be defined with the program STAR2.

CTRL - Parameters Controlling the Analysis Method

Member	Description	Type	Default
OPT	Control options	Text	I
VAL	Optional values	-/Text	*

Available options

LIT	Description	Value	Default
I	First order theory (dilatation control)	nIter	1
IB	First order theory (stress control)	nIter	1
II	Second order theory (dilatation control)	nIter	1
IIB	Second order theory (stress control)	nIter	1
III	Third order theory (dilatation control)	nIter	1
IIIB	Third order theory (stress control)	nIter	1
GEN	Force and displacement tolerance	In 0/0	1.0
GENM	Moment and rotation tolerance	In 0/0	1.1
AFIX	Managing degrees of freedom which are freely displaced	-	1
STYP	Cable element management	Text	CABL
	Cables can accept only tension	CABL	
	Cables can transfer compression	TRUS	
GDIV	Element grouping factor	-	*

Predefined value for CTRL is I, which means that analysis is going to be executed by first order theory.

As a result for predefined values, URSULA creates output data for all three load cases.

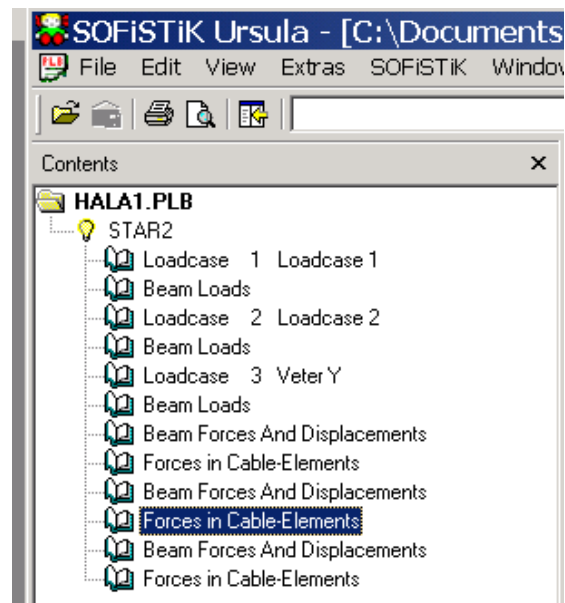

Echo of the load input data.

Beam Loads						
Beamno	type	a[m]	l[m]	load1	load2	[dim]ya[cm]za[cm]ye[cm]ze[cm]
29	ULPZ	0.000	8.040	5.00		KN/M
30	ULPZ	0.000	12.060	5.00		KN/M
31	ULPZ	0.000	12.060	5.00		KN/M
32	ULPZ	0.000	8.040	5.00		KN/M
33	ULPZ	0.000	8.040	10.00		KN/M
34	ULPZ	0.000	12.060	10.00		KN/M
35	ULPZ	0.000	12.060	10.00		KN/M
36	ULPZ	0.000	8.040	10.00		KN/M
37	ULPZ	0.000	8.040	10.00		KN/M
38	ULPZ	0.000	12.060	10.00		KN/M

Results of the static values in the beam elements.

linear		results						lc	1	Loadfactor	1.00
Beam Forces And Displacements											
Loadcase 1 Loadcase 1											
beam	X	N	V-y	V-z	M-T	M-y	M-z				
No	[m]	[kN]	[kN]	[kN]	[kNm]	[kNm]	[kNm]				
1	0.000	-76.2	-3.1	0.0	0.00	-0.19	-13.49				
	7.200	-76.2	-3.1	0.0	0.00	0.11	8.79				
2	0.000	-76.2	3.1	0.0	0.00	-0.19	13.49				
	7.200	-76.2	3.1	0.0	0.00	0.10	-8.79				
3	0.000	-25.5	-6.8	0.0	0.00	-0.11	-25.58				
	6.000	-25.5	-6.8	0.0	0.00	0.09	15.48				
4	0.000	-25.5	6.8	0.0	0.00	-0.09	25.58				
	6.000	-25.5	6.8	0.0	0.00	0.06	-15.48				
5	0.000	-147.4	-4.8	0.0	0.00	-0.11	-20.63				
	7.200	-147.4	-4.8	0.0	0.00	0.07	13.83				

Finally forces in cable elements are entered.

Forces in Cable-Elements

Loadcase	1	Loadcase 1	
Number	N[kN]	u [mm]	u-t [mm]
11	-0.1	-0.012	
12	-0.4	-0.080	
13	-0.1	-0.011	
14	-0.1	-0.014	
15	-2.6	-0.635	
16	2.4	0.587	
17	-2.6	-0.521	
18	-2.6	-0.518	
19	2.3	0.458	
20	-2.6	-0.518	
21	2.4	0.587	
22	-2.6	-0.635	
23	-0.4	-0.079	
24	-0.1	-0.013	

```

++++ warning no.      7 in program FEDE
System with SEIL elements without iteration yields false results !
When iteration not desired, please, use truss members of type FACH
----- New Page -----

```

Message at the end of the results for cable elements should be taken under consideration. If cable element results are analyzed, some elements are tensioned while others are compressed. This is not according the idea for cable elements which have to be tensioned. This warning is that case. Axial tensioned cable elements can not be achieved only by one analysis. SOFiSTiK registers such cases and sends message to use TRUSS elements in the analysis, some axial compressed elements can occur, or to solve the problem by iteration. This iteration means that after analysis is finished, structure is checked for axial compressed elements. If there are such elements they are eliminated from the model of the structure (because of high slenderness they can not bear compressive forces). Analysis is repeated with the new model. Redistribution of forces is done, so new axial compressed elements may occur. In the next iteration such elements are eliminated from the analysis and the process continues with few iterations until final solution, without axial compressed elements, is succeeded. Usually number of iterations has to be limited or other criterions for controlling exact solution are applied. To make nonlinear analysis of the structure, modification in module AQUA is done.

CTRL II 5

This problem has to be solved using second order theory with maximum 5 iterations. URSULA creates additional results. Apart from results of linear analysis (first iteration), final results are presented by eliminating compressed cable elements.

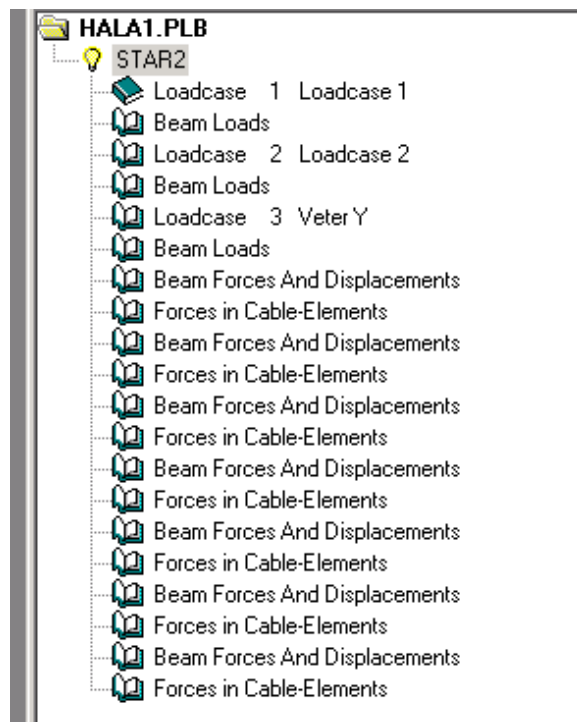

Results for cable elements clearly show that axial compressed elements were not included in the analysis.

Forces in Cable-Elements			
Nonlinear loadcase		1	Loadcase 1
Number	N [kN]	u [mm]	u-t [mm]
1	0.0	-0.068	
2	0.0	-0.080	
3	2.6	0.639	
4	0.0	-0.700	
5	2.5	0.502	
6	2.6	0.508	
7	0.0	-0.575	
8	2.6	0.507	
9	0.0	-0.700	
10	2.6	0.638	
11	0.0	-0.020	
12	0.0	-0.077	
13	0.0	-0.017	
14	0.0	-0.029	
15	0.0	-0.000	

There is no compression in the cables.

4.14.5 ECHO - Control of the Output Extent

Member	Description	Type	Default
OPT	Text from the applied list	Text	FULL
	Node coordinates, limitations	NODE	
	Beams	BEAM	
	Springs	SPRI	
	Boundary elements	BOUN	
	Cross section values	SECT	
	Loads	LOAD	
	Cross section forces	FORC	
	Beam deformations	DEFO	
	Node displacements	BDEF	
	Reinforcement	REIN	
	Stress and strain	NSTR	
	Output results for all iterations	STEP	
	All options	FULL	
VAL	Output option values	Text	FULL
	No output results	NO	
	Standard output results	YES	
	Complete output results	FULL	
	Extended output results	EXTR	

Predefined values:

ECHO full no
Echo forc,load full

denote complete output for forces and loads.

4.14.6 +PROG GRAF

Graphical presentation of results

Program GRAF is called up again to insert drawings with results from analysis. By default only results from the first load case (LC 1) are entered.

LC 1
BEAM VZ
BEAM MY
BEAM N

For results and other load cases input results have to be added in GRAF.

4.14.7 BEAM -Beam Element Results

Member	Description	Type	Default
TYPE	Type of structural element	Text	-
UNIT	Values presented with 1 cm	*	*
SCHH	Text height	cm	H6
STYP	Type of elements	SPRI	
	Boundary elements	BOUN	
	Cross section values BEAM beam element CABL cable element TRUS truss element	Text	*

	PIPE pipe element (pile)		
DTYP	Type of representation	Text	*
UNI2	Same as UNIT for second type	*	*
MNO	Number of material for composite sections or text for point which stress is calculated in AQUA	-	*
STAT	MAX maximums only END maximums and beam endings SECT all beam sections	Text	END
MIN	Lower text limit	*	0.
MIN2	Lower text limit for second type	*	0.
OFFS	Text distance	cm	0.
ND	Number of decimal places	-	*
VAL	Output option values	Text	FULL

By default only graphical results of beams are displayed.

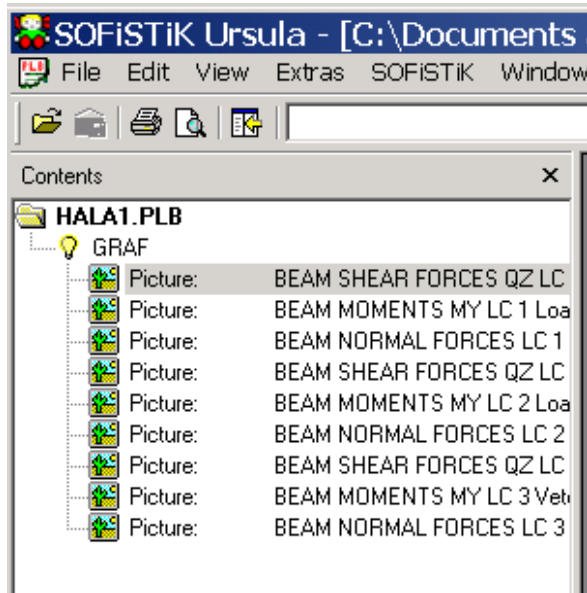

Nine new drawings are entered in the book of results.

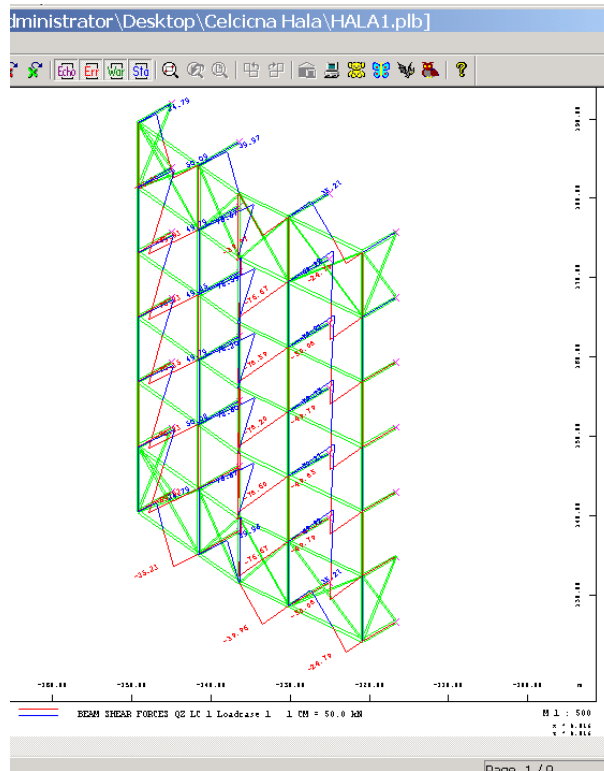

Icon Rotate Picture is used for rotating the drawing for 90° , in one or the other direction. For this purpose drawing should be first selected by clicking with the mouse on the drawing in URSULA, and then icon depending rotation direction is clicked.

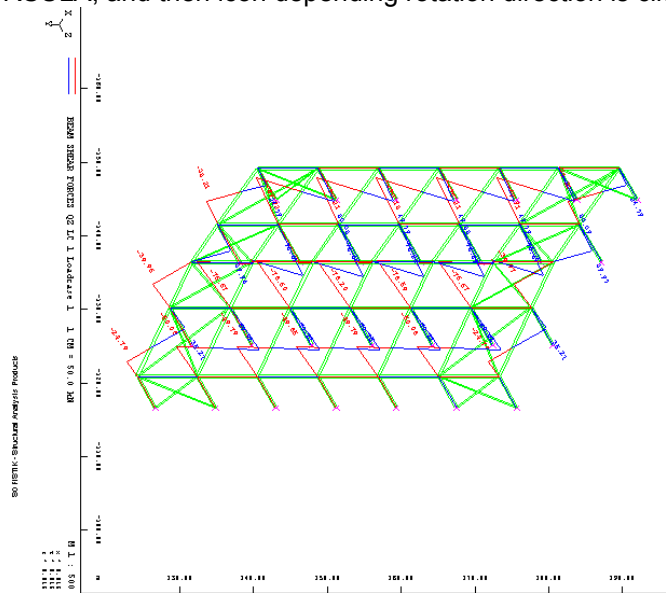

Next click on the icon rotates the picture for another 90° and so on until desired orientation of the drawing is achieved. Results for cables can be displayed in addition.

Because results from the analysis are in analysis database they can be shown separately.

For instance, if new book with drawings, which will contain only cable forces, has to be created unneeded modules are switched off (by clicking the + sign becomes -).

Change in GRAF is made so only cable forces are drawn.

```
+PROG GRAF -E urs:4
VIEW STAN 1 1 1 POSY
```

```

SIZE HP4
LC 1
BEAM N STYP CABL      $ Cable N
LC 2
BEAM N STYP CABL      $ Cable N
LC 3
BEAM N STYP CABL      $ Cable N
END

```

and all modules except GRAF are turned off.



As a result of these changes, new book with drawings is created,

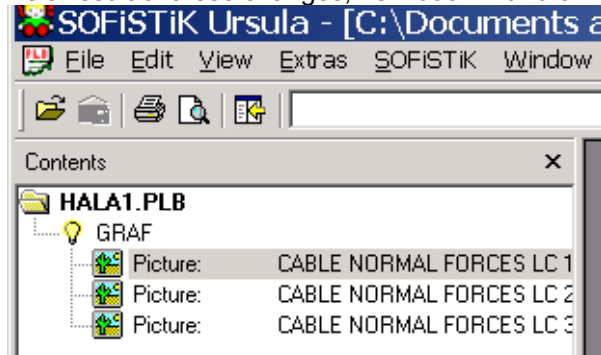

where cable element forces are introduced.

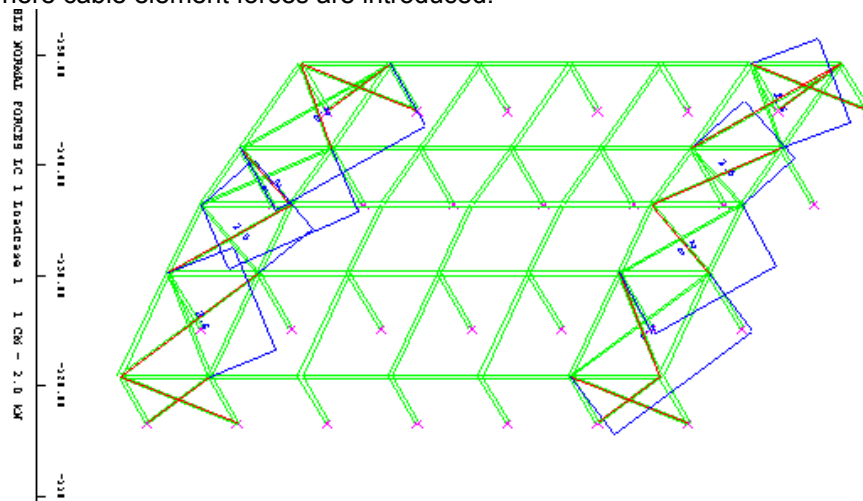

5. Example 2 : Administrative Building

This building is octagon based, with edge length of 10 meters. Cross sections of the floors are shown on the following pictures. First, slabs are analyzed as independent structural systems. Three floors are characteristic: basement floor, ground floor and first floor.

5.1 BASEMENT:

The outline contour of the slab is supported on concrete walls with thickness of 20 cm. Slab in the center has 5 m round opening. Supports in the center are circle columns with 40 cm in diameter.

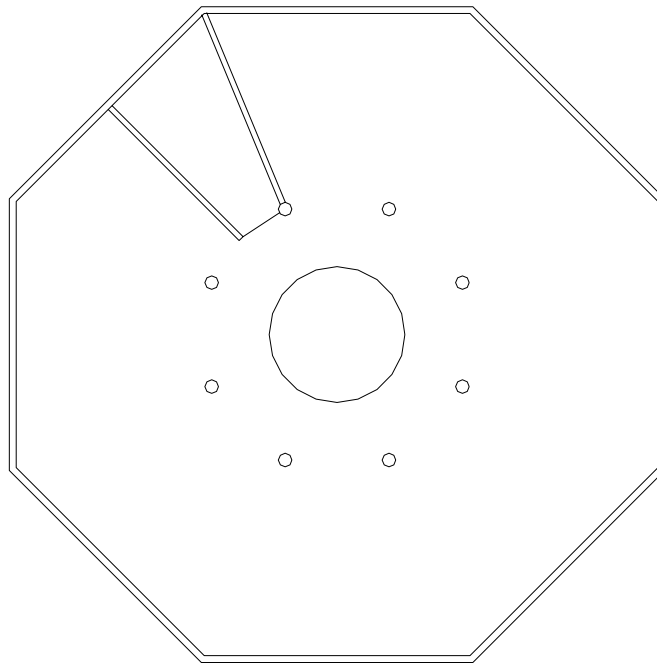

Stairs are surrounded by two concrete walls ($d=15$ cm). For simplifying the analysis, stairs slabs are not included in the mathematical model.

5.2 STRUCTURAL SYSTEM

Structural system is Girder/Slab grid. Analysis is going to be performed according Euro Code (EC 2). Structural system is set with:



ICON: Structural system
 MENU: SOFiPLUS → Structural system...
 Command: SOF_GSYSMOD

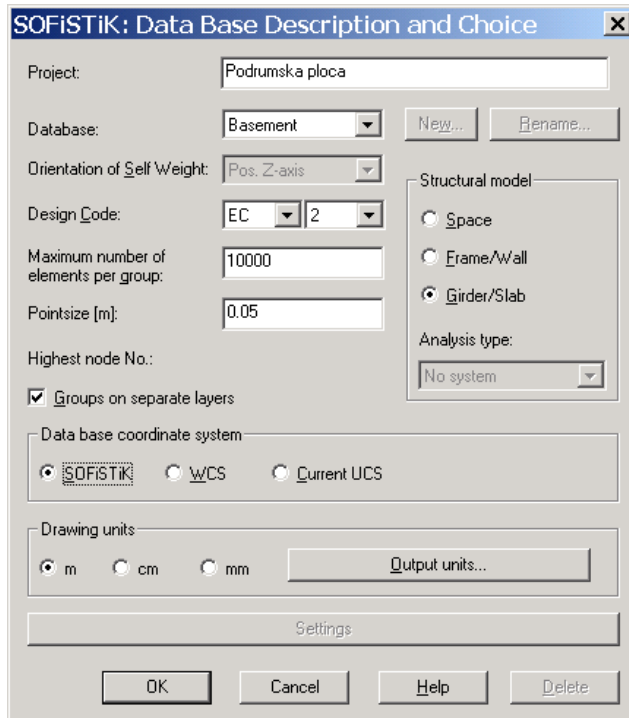

In *Data Base Description and Choice* dialogue box following parameters are entered in the database.

Project	Podrumska ploca
Database	Basement
Orientation of Self Weight:	Pos. Z axis
Maximum number of element per group	10000
Point size	0.05
Structural mode	Girder/Slab
Database coordinate system	SOFiSTiK
Drawing units	m

Database file is created after closing the dialogue box. The file name is: BASEMENT

5.3 MATERIAL

Slab is made from concrete with strength 35.



ICON: Material
 MENU: SOFiPLUS →Defined model→Material
 Command: SOF_GSYMATE

Dialogue box shows predefined materials which are not used in this example.

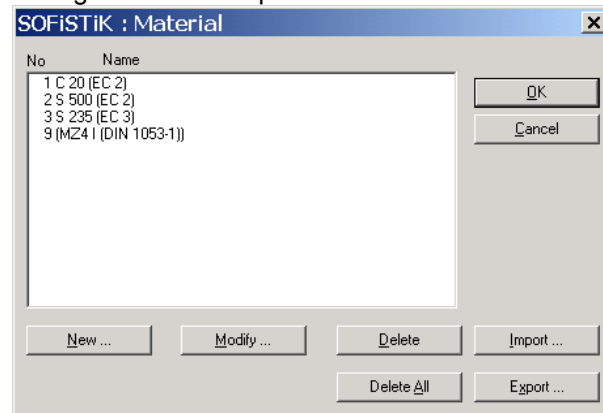

Modify concrete strength. Select the material which is going to be modified (1 C 20 in the example). Pressing on the Modify button opens dialogue box which permits changing material properties.

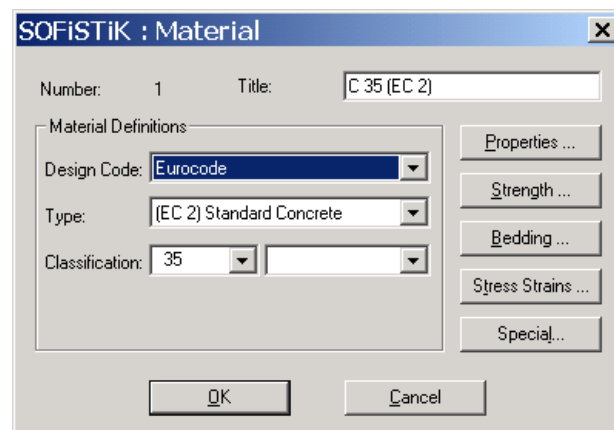

Type (EC 2) Standard Concrete
 Classification 35

Reinforcing material remains unchanged S 500. The rest two predefined materials can be deleted.

5.4 STRUCTURAL LINES

As a background for defining mathematical model, architectural drawing of the basement floor is used. This drawing can be used for filling structural lines which are later used for generating mathematical model. For outward walls usually slab contour is considered passing on 1/3 of the wall thickness.

For this purpose following command is used:

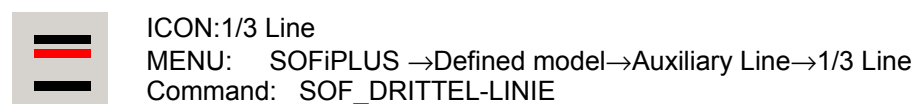

First click on the inner line of the wall and then on the outline. SOFiPLUS draws structural line on 1/3 of the inner side of the wall

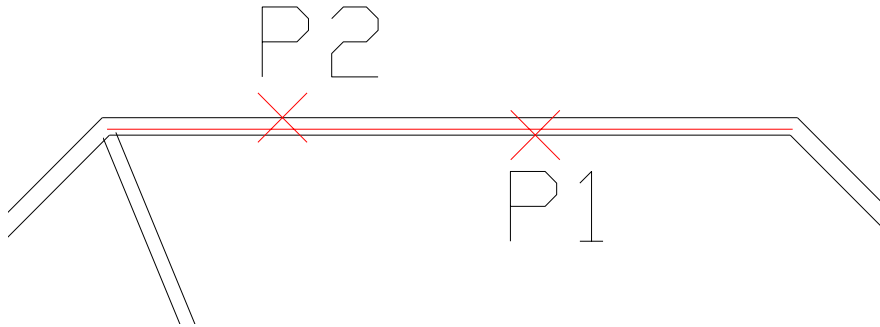

This command is used for drawing structural lines on all outward walls.

Inner walls are represented by structural lines passing in the middle of the wall.

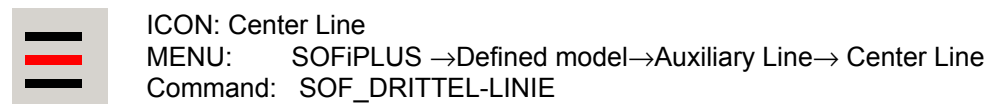

In this case order of selecting sides of the wall is not important.

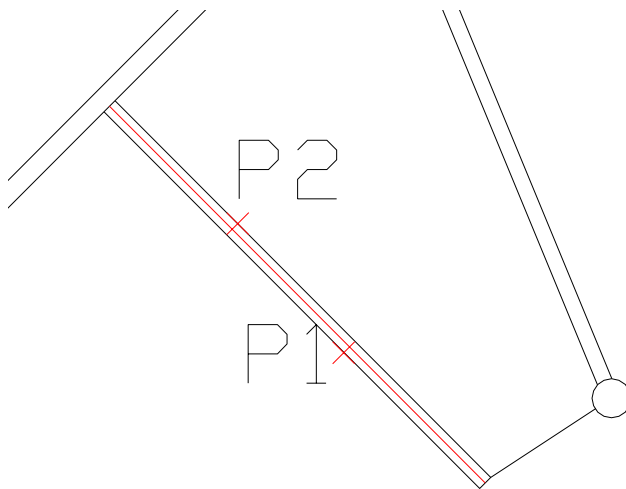

This procedure continues with drawing structural line on the second inner wall. All structural elements are placed on later: X_AUFL



which is formed by SOFiPLUS.

Beside these lines additional structural lines are going to be drawn. Using the simple AutoCAD command: Line, draw lines on the contours of the slab segments. These lines have to be placed on layer X_AUFL. If these lines are not entered on the layer X_AUFL when they are drawn, relocation can be done in few ways using AutoCAD commands (Properties, Match Properties tool, ...) or by simply clicking on the lines (grip points are showing) then clicking on the icon Layers and selecting the layer X_AUFL from the layer list.

SOFIPLUS has its own function which transfers graphical objects on structural layer.

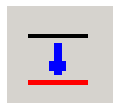

ICON: Copy to structural Layer
 MENU: SOFIPLUS→Defined model→Auxiliary Line→S Copy to structural Layer
 Command: SOF_DRITTEL-LINIE

After selecting this command, click on the auxiliary lines which are transferred on layer X__AUFL and represent structural lines.
 This group of tools has another tool: User define Factor, which allows optional position of structural line in relation to wall edges.



ICONA: User Defined Factor
 MENU: SOFIPLUS →Defined model→Auxiliary Line→S Copy to Structural Layer
 Command: SOF_DRITTEL-LINIE

Command:
 Factor <0.5000>: 0.25 (Line passes on ¼ of the first selected wall edge)
 First line (Select the first wall side)
 Second line (Select the second wall side)
 First line (Continue with other walls)

5.5 STRUCTURE AREAS

Structure areas are parts of slab surrounded by structural lines. There are two ways of generating structural areas: by clicking on the point inside contours of the area (structural lines must form closed contour) or by clicking certain structural lines which form slab contour area. In the second case lines do not have to intersect. SOFIPLUS continues lines to their intersection points. It is important to generate lines in clock-wise or opposite direction and to form closed contour. In this example first case is shown in the beginning.



ICON: Structure area
 MENU: SOFIPLUS→Defined model→Structure area
 Command: SOF_PM_AREA

Before defining structural areas it is preferable to close all layers except layer with the structural lines. After that component check of structural lines is needed in order to eliminate errors (usually contours are not ideally closed) or to choose forming of the areas by selecting contour lines which do not need closed contours.

Simplest way is by clicking on closed contour. After selecting this option, dialogue box appears on the screen asking for slab parameters.

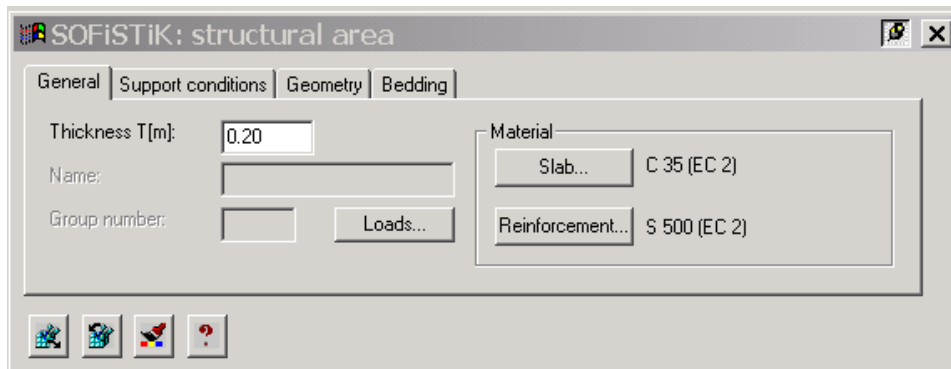

Predefined slab thickness is 20 cm. It should be changed to 18 cm. If change of the material is necessary, buttons *Slab* (for concrete) and *Reinforcement* are used. Both buttons open *Material* dialogue box which allows change of accepted materials. Button *Load...* starts the process of defining loads for the area which is going to be generated. After the first launch of *Loads...*, *Load case Manager* dialogue box opens because there are no previous loads defined. In this dialogue box all load cases, which will be used in the slab analysis are entered and current load case is the first one for which load is going to be generated. In the example it is 1 Loadcase Dead Load.

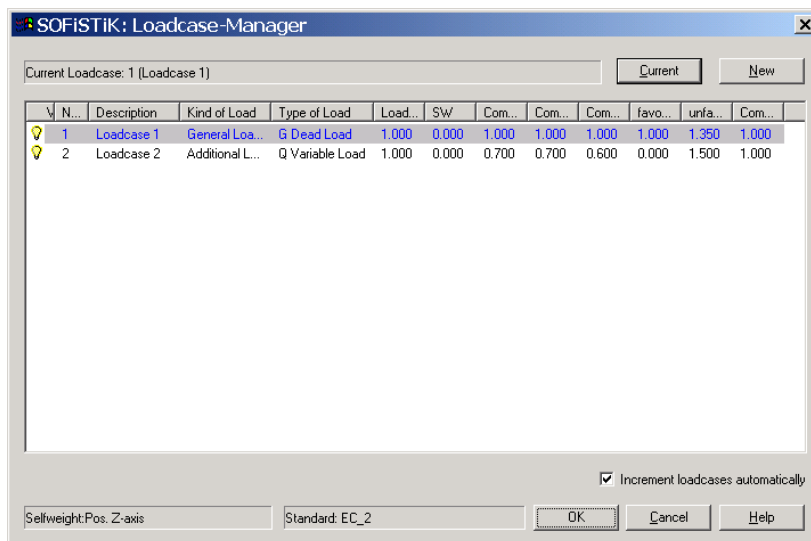

5.6 Loads and Areas dialogue box

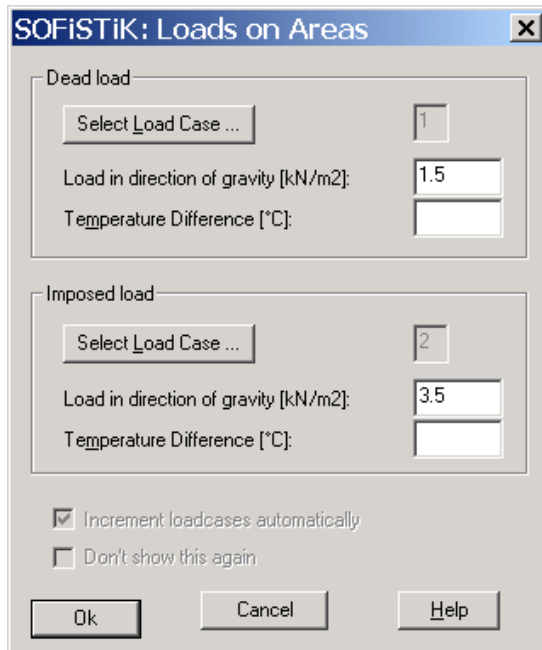

allows selecting load case for dead and imposed load as well as entering load values and temperature difference. Since loads are placed on correct positions, click inside closed contour. SOFiPLUS analysis contour and if everything is properly entered and defined, marks the contour and displays area labels and loads.

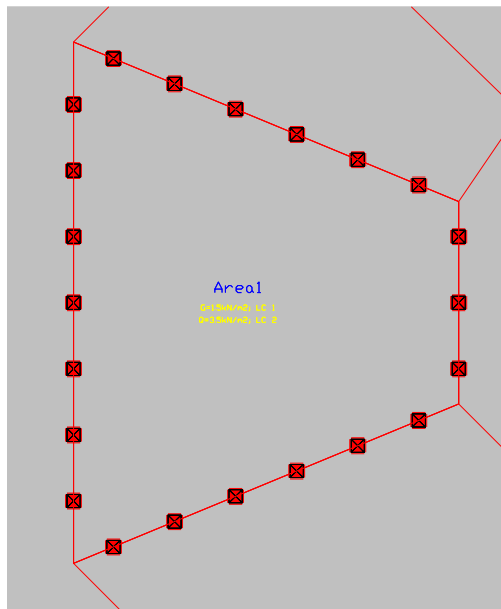

Process continues by setting point lying on the next closed contour. Before contour is selected dialogue box appears again, but with increased value for Imposed Load. When selecting closed contours, they should be fully visible on the screen.

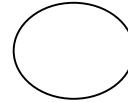
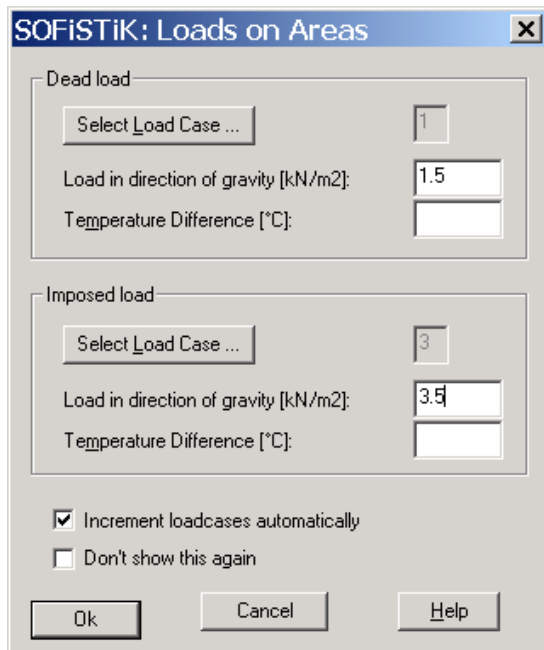

Every slab area can have new load case for Imposed Load. In that case by combining load cases checkmate disposition of Imposed Load is available for inspection or determination of the unfavorable disposition in certain slab areas.

We should discuss about two check boxes: Increment loadcase automatically (presumed option) and Don't show this again. As stated before checking the first check box automatically increases the number of load case in which Imposed load for specified load is placed. The second check box is active only when all areas are uniformly stressed. In such cases *Loads and Areas* dialogue box do not appears, so predefined load values are declared on the areas. In this example we will use the second option: *Don't show this again*, meaning all areas have same load values.

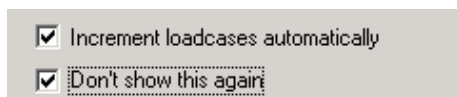

Center part of the slab can not be created on the previous way. This part contains opening which has to be defined separately. Use: *Select Boundary* option:

Command:

pick Point in area or [Select Boundary]:
 pick Point in area or [Select Boundary]:
 pick Point in area or [Select Boundary]: S

We should be very careful when using this method. When selecting two structural lines SOFiPLUS checks these lines and if the operation is regular marks the lines with one label for each line.

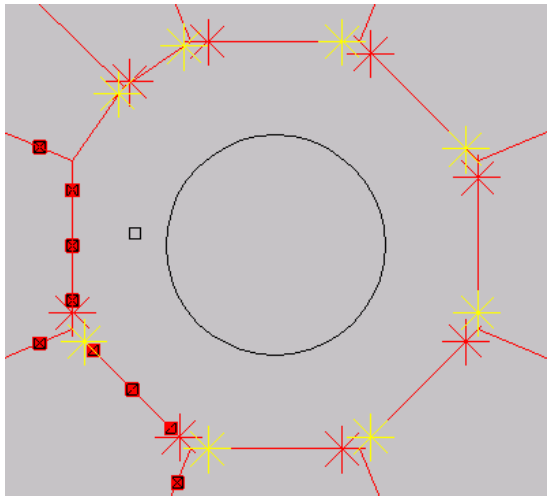

In some cases a line can be contained in few areas and when selecting SOFiPLUS does not identifies that line (line marking is skipped). Then we have to repeat selection by holding down CTRL and clicking on the line. Thereby cycle selection process is started.

Select Boundary or [Undo]: <Cycle on>

At this time click again on the line (without holding down the CTRL button). By every selection, next element with area equal to previous is selected. Continue clicking until right element is selected and then click on *Entry* to finish cycle selection process. If everything is regular new area is created on the slab.

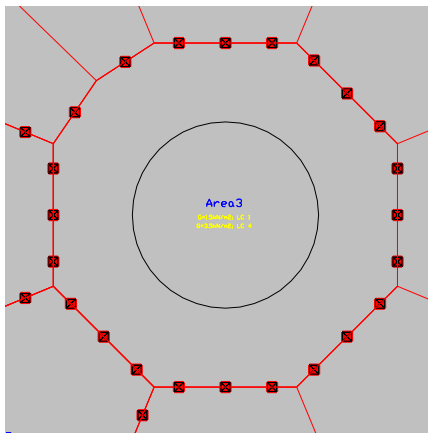

At the end slab opening should be created.



ICON: Opening
 MENI: SOFiPLUS→Defined model→ Opening
 Command: SOF_PM_HOLE

This way of creating openings is exactly the same as when creating slab areas. You can click on the closed contour of the opening or gradually select contour lines of the opening. This example uses first option because center slab opening has round shape.

COLUMNS

In the center area, our slab is supported on circle columns. In the mathematical model columns should be presented as point supports with permitted rotations and constraint

vertical displacements. This way of defining columns is not correct. Point slab support is reason for singularity and from the theory moments in point supports are infinite. Finite element solution is approximate and depends on the size of the elements. If finer grid (smaller elements) is used, precision is increased which means greater values for moments. In reality slabs are not point supported by columns.

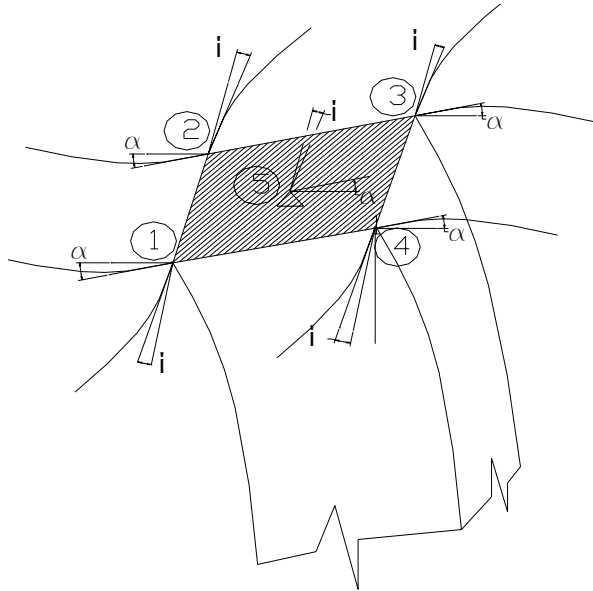

$$\alpha_1 = \alpha_2 = \alpha_3 = \alpha_4 = \alpha_5$$

$$\beta_1 = \beta_2 = \beta_3 = \beta_4 = \beta_5$$

It can be presumed that the part of the slab which is lying on the column acts as solid which has same deformations as end of the column. Mathematically this means prescribing same rotations and vertical displacements to all points which lay on the area connecting the slab and column. In final element method this is simulated using CONSTRAN, by equalizing deformations of those points (in this example point 1-4) with reference

point (point 5).

Other way to simulate columns is thru elastic supports on points where columns support the slab. Axial and rotational stiffness is calculated on the columns and they are replaced with equivalent axial and rotational springs. SOFiPLUS supports both ways of approximating columns: CONSTRAINS and elastic springs. This example uses the second way of approximation by applying elastic springs.



ICON: Structure Point
MENU: SOFiPLUS→Defined model→Column/Structure Point
Command: SOF_PM_POINT

Structure point dialogue box contains several tabs. First tab *General* is used for applying the name of the point/column, dimensions (x and y), positive X axis angle and slab thickness.

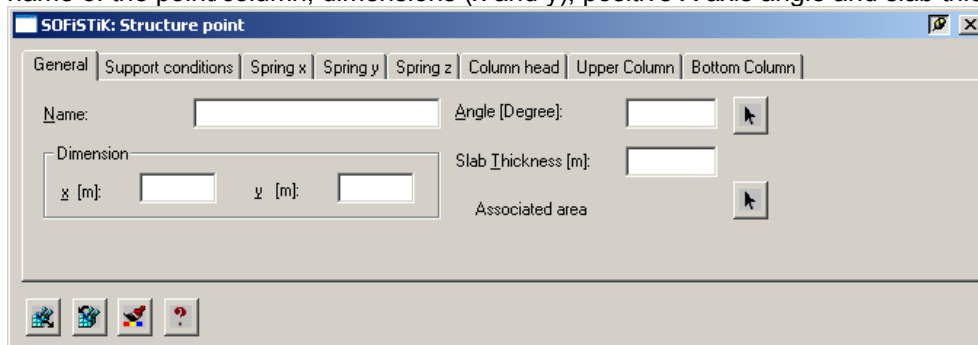

x and y are dimensions of the area which approximates column supports. *Angle* is formed between local X-axis of the support and global X-axis of the system. Column cross sections can be assumed from the drawing by selecting column contours.

Command: SOF_PM_POINT

pick Position (end+cen+int+ext) or [Outer boundary/Point in column]: **O**

Select Boundary: (Select column boundaries)

or

pick Position (end+cen+int+ext) or [Outer boundary/ Point in column]: **P** (Select column interior)

If second option is used, we should be careful to enable clear column surface without other closed contours. SOFiPLUS recognizes closed contours and defines support point for every clicked closed contour. In this example first option *Select Boundary* is used. Selection of column boundaries is performed the same way as selection of slab area boundaries. So, if several boundaries are present, neighboring boundaries are selected in clock-wise direction or vice versa. Columns with circle and user defined cross sections are replaced by equivalent square columns.

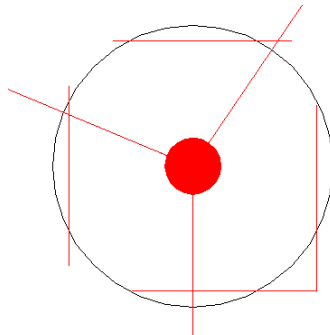

In order to display SOF_PM_POINT effects, following command is activated:



ICON: Modify Structure Point
 MENU: SOFiPLUS→Defined model→Modify Column/Structure Point
 Command: SOF_PM_POINT_M

and columns is selected so as to check/modify its parameters.

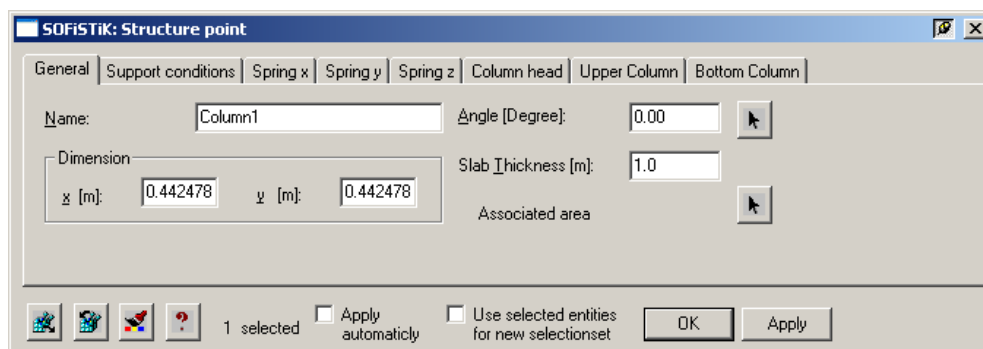

Dialogue box in x and y text boxes shows equivalent dimensions of the square column. Enter slab thickness in the *Slab Thickness* text box.

Support conditions of the point/column are entered in *Support conditions* tab.

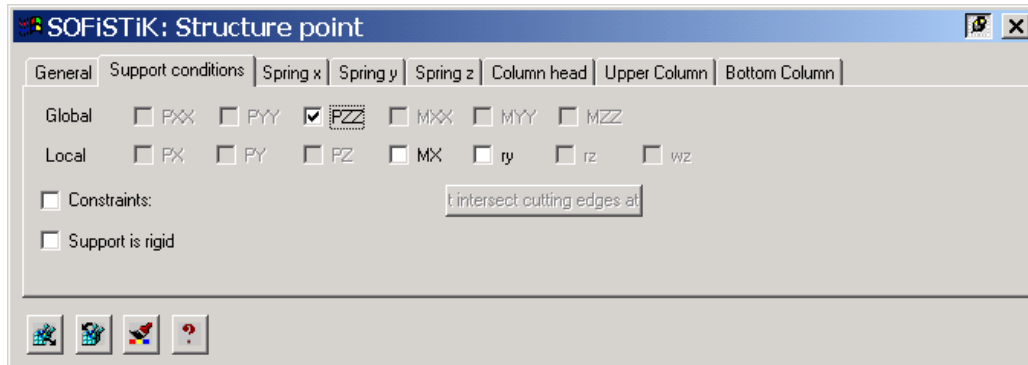

Restrain vertical displacement of the point by checking the PZZ check box. With the purpose of calculating rotational stiffness, their dimensions and beam heads, if present, should be entered. Use *Upper Column* tab to apply these settings.

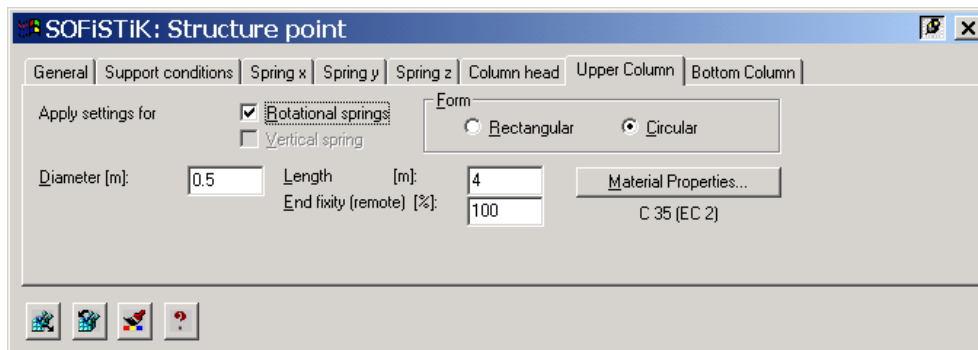

Button Column

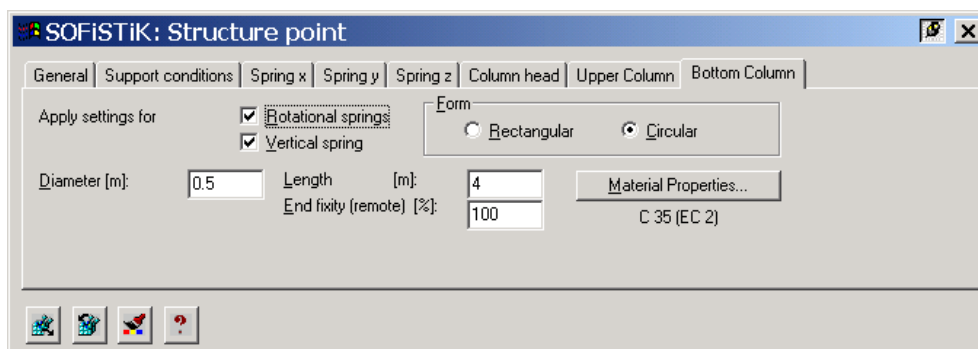

and Column head.

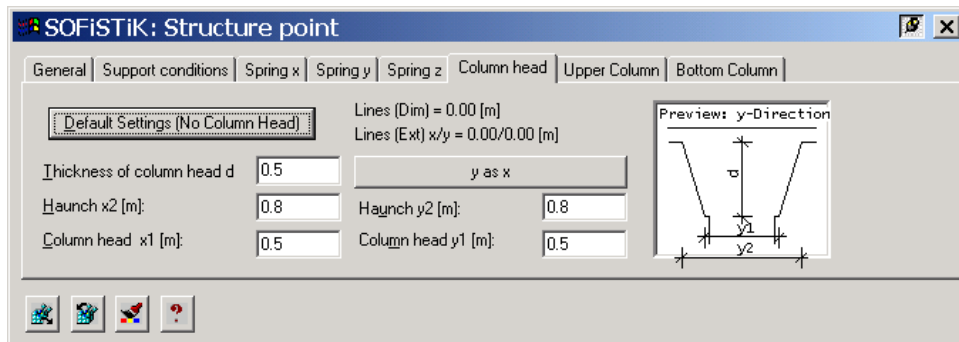

Upper column can be replaced with rotational spring (check *Rotational spring* box), while lower column can be replaced with rotational and vertical spring (check the *Rotational spring* and *Vertical spring* check box). SOFIPLUS calculates spring values and they can be shown or edited in *Spring x* and *Spring y* tabs.

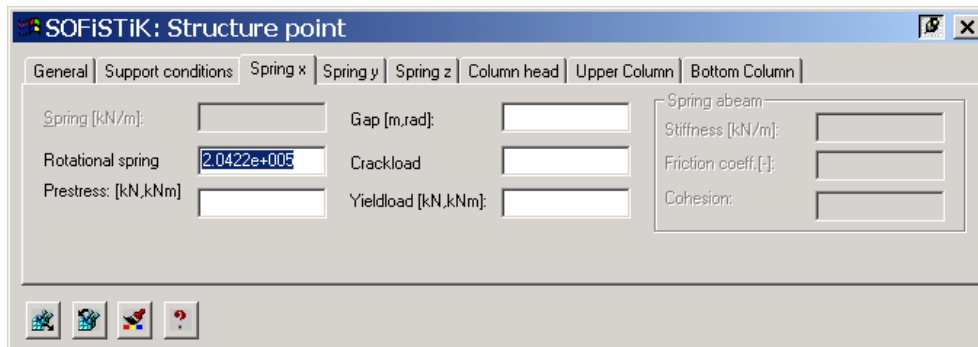

or Spring z.

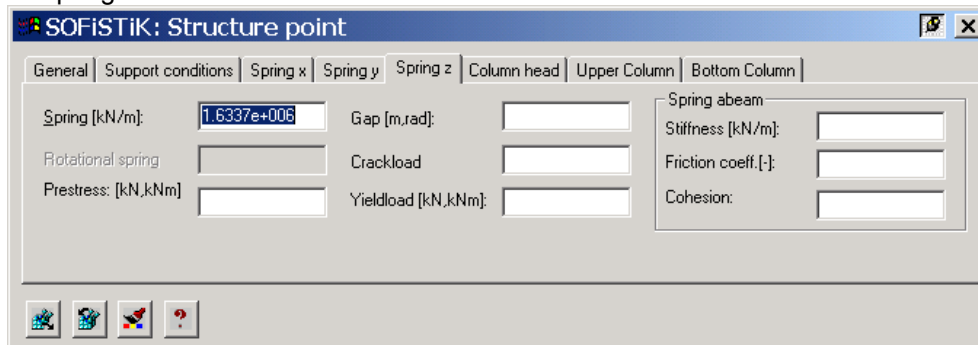

If modifications in circle column characteristics are needed a message box may appear:

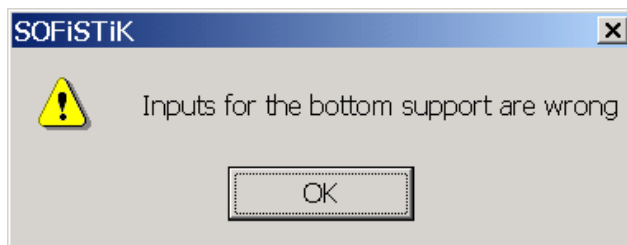

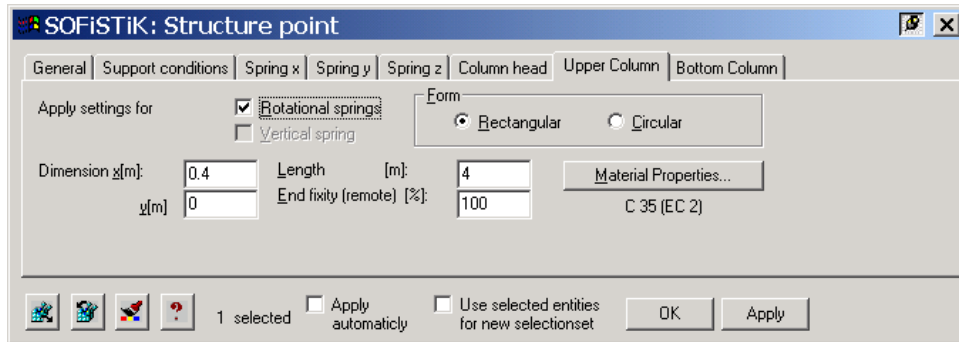

This message pops up because by default this dialogue box opens as for rectangular column.



This error occurs because the y value for dimensions is 0. This error is eliminated by checking *Circular* in the form field.

When the first column is entered, the *Structural Point/Column* command remains active and the next structural points or columns can be entered.

If the *Structural Point/Column* dialog box is necessary to be started several times, input data may be entered using the following options:

	Save values into registry	Data values are saved in the registry.
	Read values from registry	Previous saved data are read from the registry.

5.7 SUPPORTS

By assumption, slab areas are formed as freely supported on boundary edges. Usually, additional modifications on slab boundary edges are required with the intention of releasing unnecessary restraints. Modifications can be done by:

5.7.1 Info/Edit and Modify Structure Edge

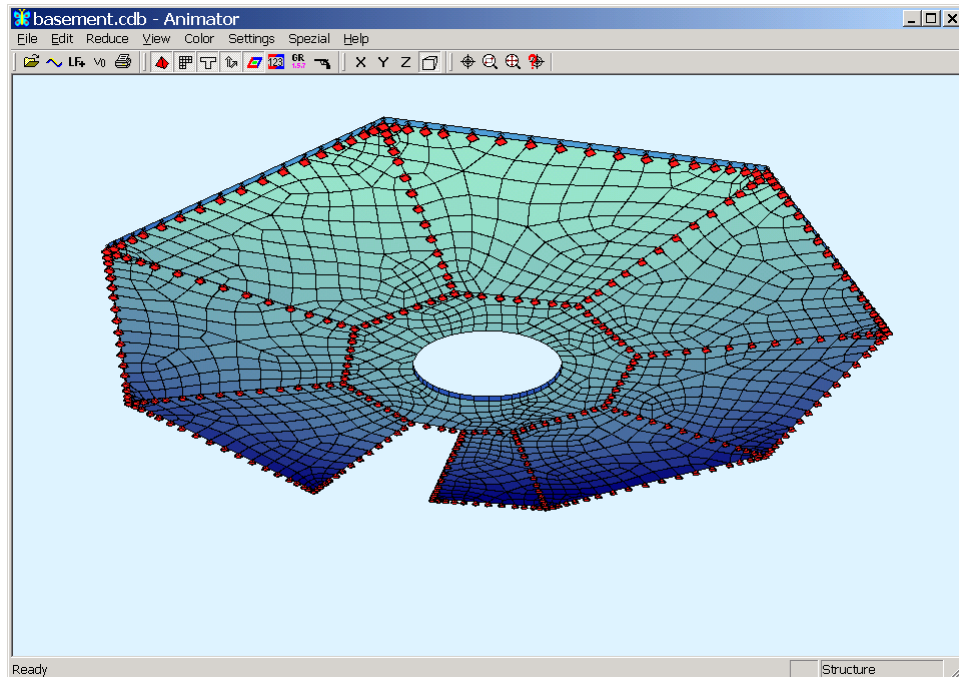

In this example, inner slab area is supported only by columns (without beams). Therefore, displacements in Z direction of the inner edges should be released. For illustration purposes, both methods are shown.



ICON: Info/Edit
 MENU: SOFiPLUS→Info/Edit...
 Command: SOF_GINFO

Select the edge to be modified. Edge can belong to different structural elements, so in the following dialogue box

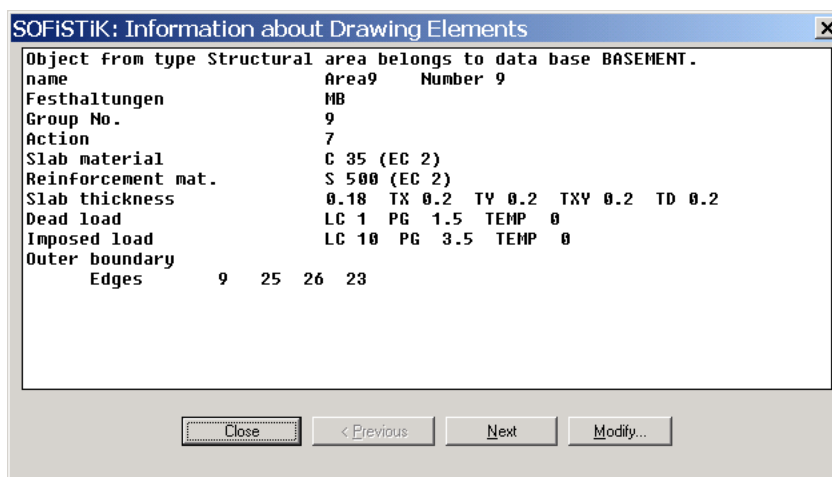

the right structural element to be modified may not be shown. For example, in this dialogue box information for one slab area are shown which has one equal edge with the selected edge. In such cases Next button is used to show the next selected edge. All subsequent elements are listed until desired edge information are shown.

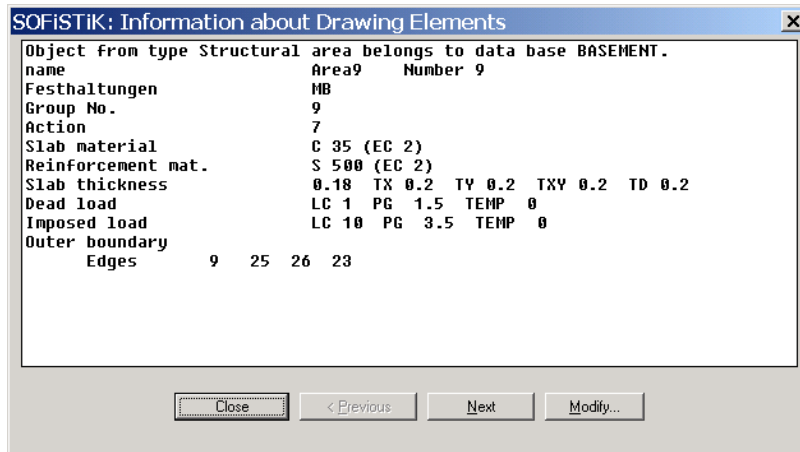

Click on the *Modify* button to open *Support conditions* tab. Uncheck the PZZ check box

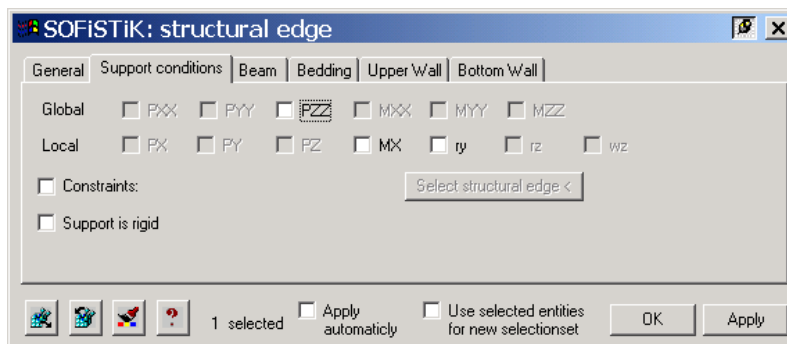

and click on *Apply* to make changes on the edge.

This method is used when structural element information or individual modifications of structural elements are needed.

Whenever simultaneous modifications of several elements are required much better to use is the second method for alteration.

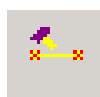

ICON: Modify Structural Edges
 MENU: SOFIPLUS→Modify model→Structural Edges
 Command: SOF_SOF_PM_EDGE_M

Select all structural edges to be modified. In the *Structural edge* dialogue box

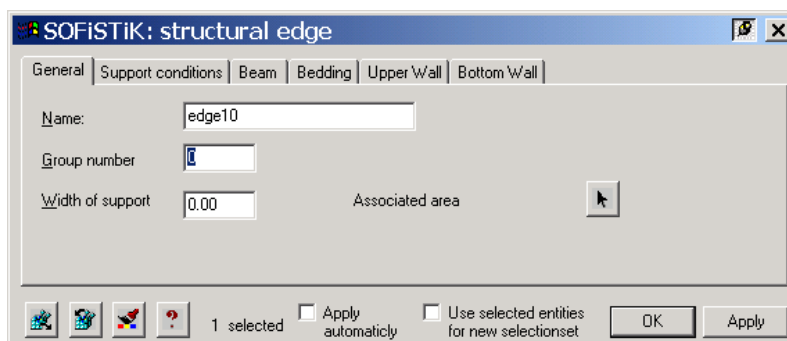

pick *Support conditions* tab and change PZZ input as previously described in *Info/Edit* command.

Staircase of the building is limited by two reinforced walls. Reinforced concrete beam is allocated with cross section: $b/h=25/50$ sm.

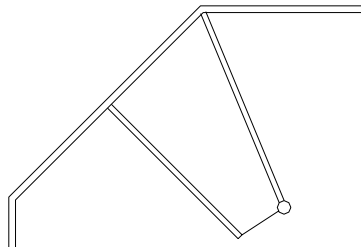

$b/h = 25/50$

On the slab edge few modifications are necessary: to be replaced with beam and to allow displacements in Z direction. By *Info/Edit* or *Modify Structural Edge* command, select the edge. Support conditions are modified in Support conditions tab as previously described. After that open *Beam* tab,

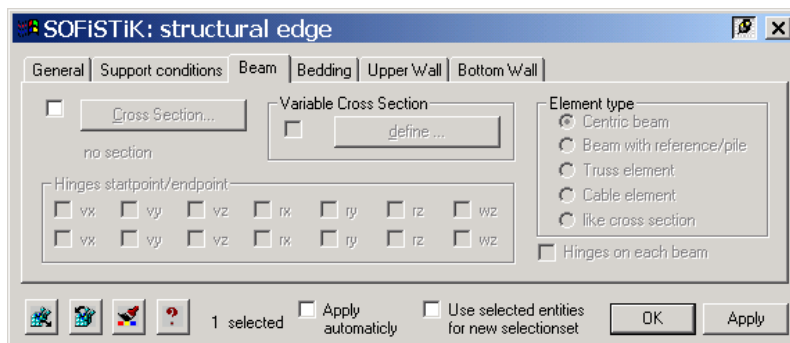

mark *Cross section* check box, *Cross Section* button becomes active and *Cross Section* dialogue box is opened,

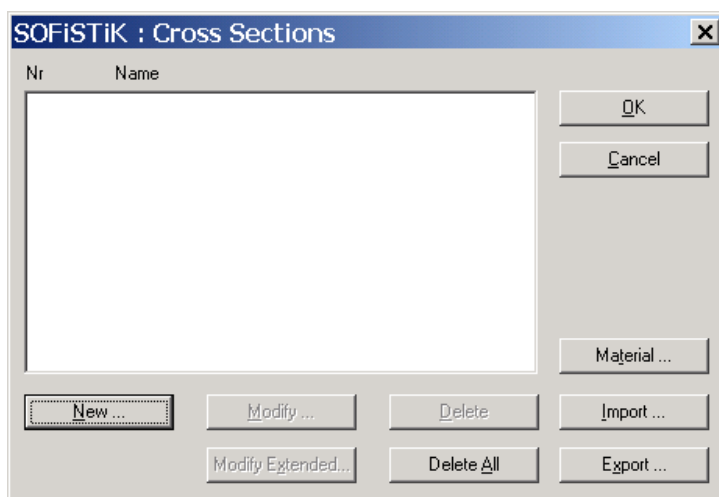

where clicking on *New...* starts the process for creating new cross section. Select *Rectangle* from the list

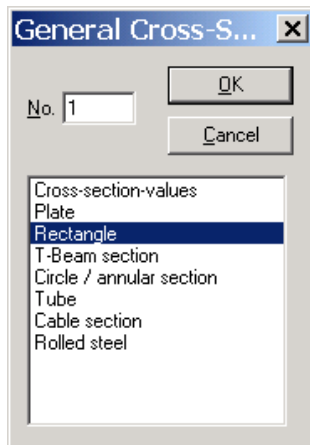

and enter beam cross section data.

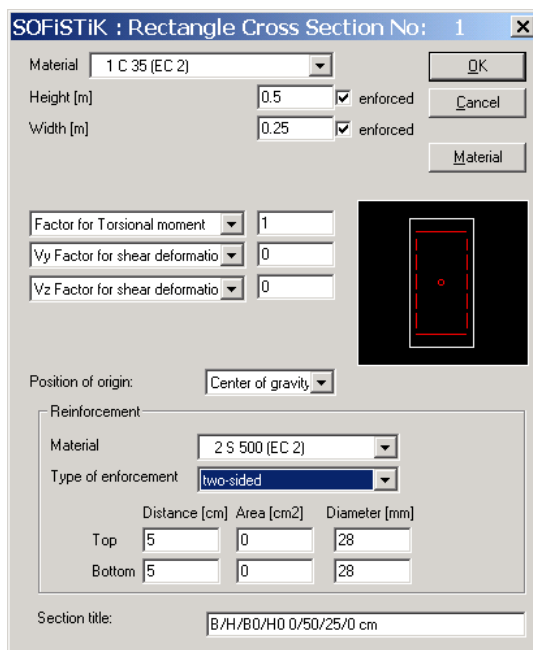

On edges slab are supported on reinforced concrete walls. Usually this way of supporting slabs is replaced with fixed supports. More accurate to use is elastic fixing where elastic stiffness of the support is equivalent to wall stiffness. Change in contour edge characteristics are done with *Info/Edit* or *Modify Structural Edge* command. To input wall characteristics open *Upper Wall* tab

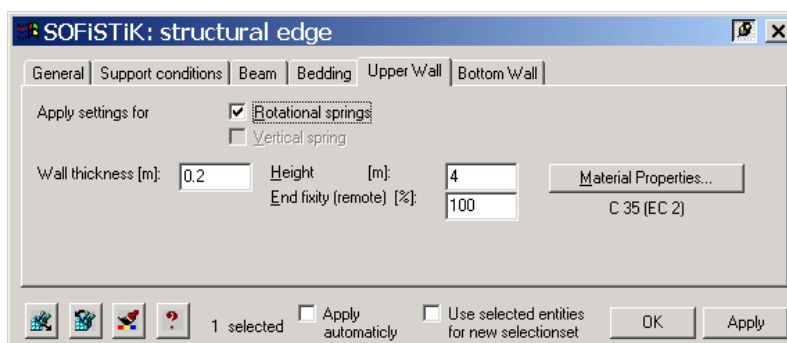

and Button Wall

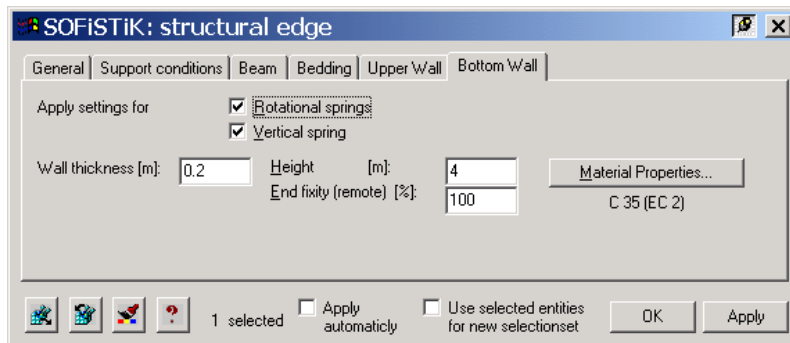

and enter proper dimensions for *Wall thickness*, *Wall Height* and *End fixity*.
If you click on *Info/Edit* command and select any edge beam you should see that rotational springs are entered along edge element length.

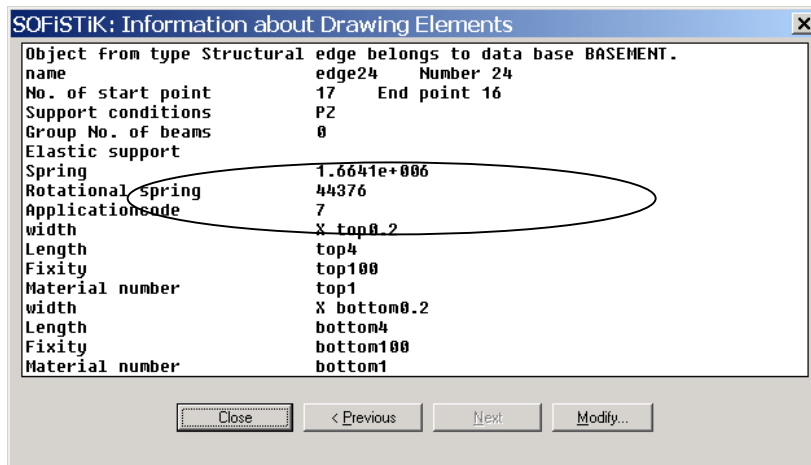

5.8 FINITE ELEMENT MESH

Three ways to define finite element mesh are possible.

Automatic
With objects
With macros

In this example first way to define finite element mesh is used.



ICON: Mesh Generation
MENU: SOFiPLUS→Generate→Automatic mesh generation
Command: SOF_G_MASHGEN

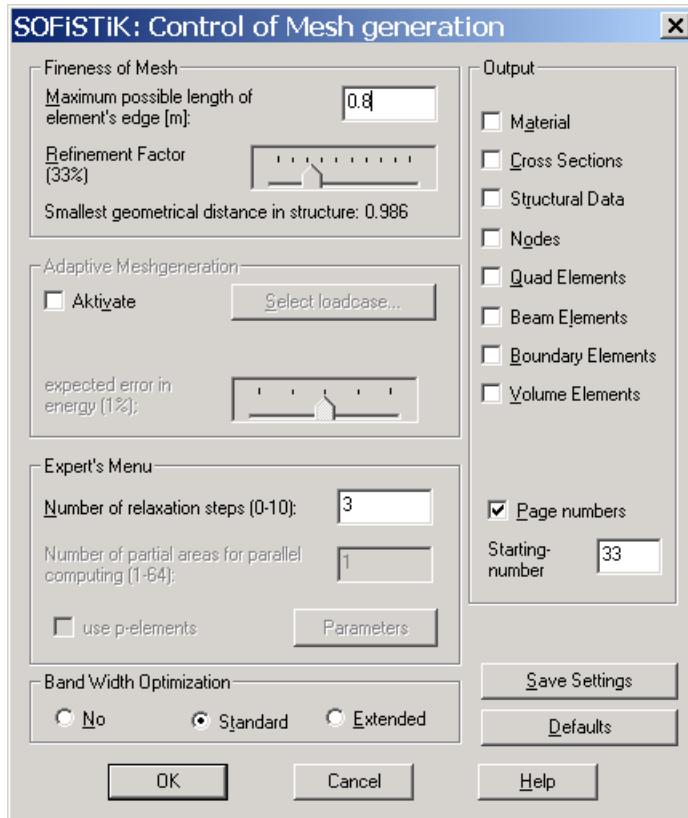

5.8.1 *Maximum possible length of element's edge*

Defines maximum element length. This length is used for automatic mesh generation. As default length, double value of the smallest geometrical distance is offered. Smaller elements are required around structural points (supports and short edges).

NOTE: In order to calculate correct moments, one slab area should be approximated with at least 6 to 8 elements in any direction.

5.8.2 *Number of relaxation steps*

By selecting more relaxation steps, geometry of elements is improved. We should have in mind that every relaxation step spends a lot of computer time to calculate and we should select optimal number of relaxation steps. Usually 3 steps are enough for acceptable solution.

5.8.3 *Output*

When generating the mesh, output file may be created "Database_name.ER1" where numerical results are inputted. By checking certain check boxes you determine which data are inputted in the file.

5.8.4 *Page numbers*

Enters number of the first page. If check box is not marked, page numbering is not fulfilled.

5.8.5 *Activate*

If this check box is marked, mesh can be adjusted according selected load case.

5.8.6 *Band Width Optimization*

When mathematical model is created, node numbering is performed (shall not be sequential numbering) and the program itself declares internal node numbers. Calculation speed depends on the difference between maximal and minimal number of nodes in the

element (band width). In order to increase the calculation speed renumbering of the internal nodes is carried out and smaller band width is acquired.

5.9 STRUCTURE CONTROL

Since finite element mesh is generated it is desirable to make visual control. Start the Animator.

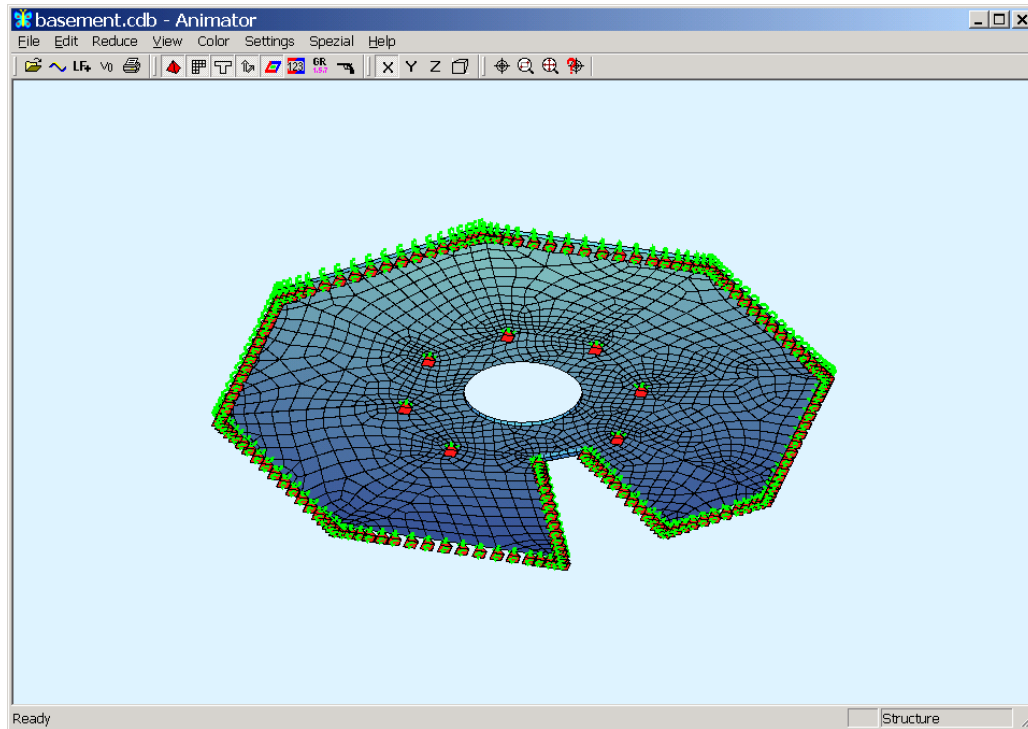

Check the structure using Animator tools.

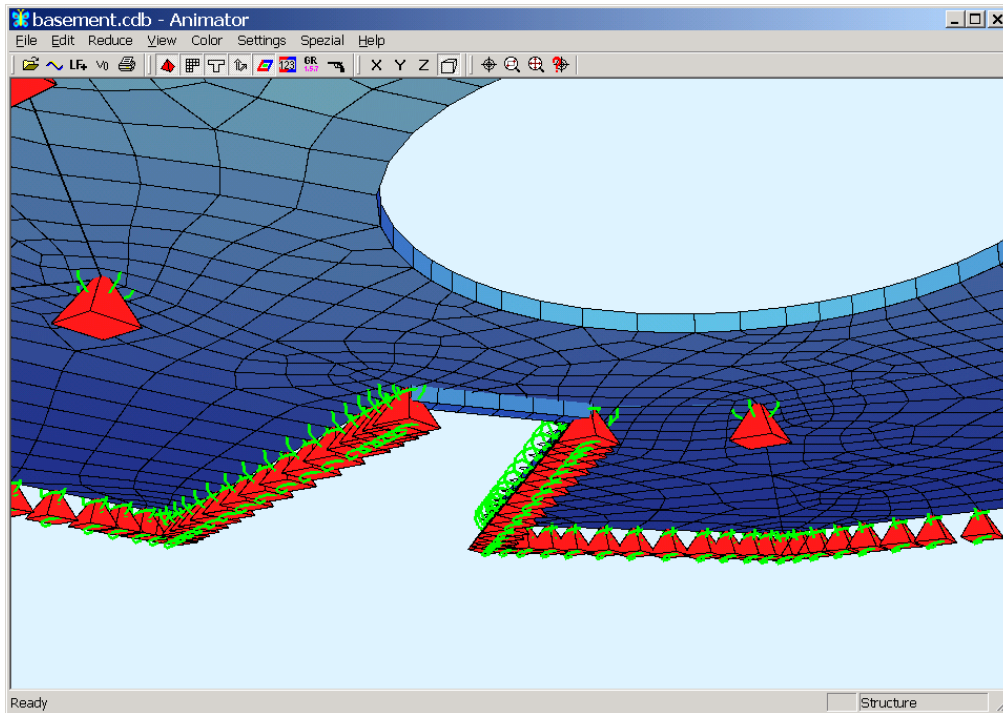

5.10 IMPORT ANALYSIS DATABASE

When generation is finished, finite element mesh is invisible to the user. If the mesh is required to be visible on the screen, analysis database should be imported.



ICON: Import

MENU: SOFiPLUS→Analysis Data Base (CDB)→Import (.cdb→.dwg)

Command: SOF_GENFIN

Default name of the active database is entered in the *Name* text box. With the *Browse...* button other analysis database may be imported into the drawing. By marking or demarking check boxes a change in the imported database can be fulfilled. After closing this dialogue box, program reads finite element mesh and displays it into the drawing. Good control of the mesh is required as well as mesh density at singular points, points with concentrated loads and similar critical areas. Unless user is satisfied by automatic generated mash, certain adjustments have to be prepared in Control mesh generation dialogue box and finite element mesh generation process has to be repeated. Specific situations demand additional structural points, edges and etc.

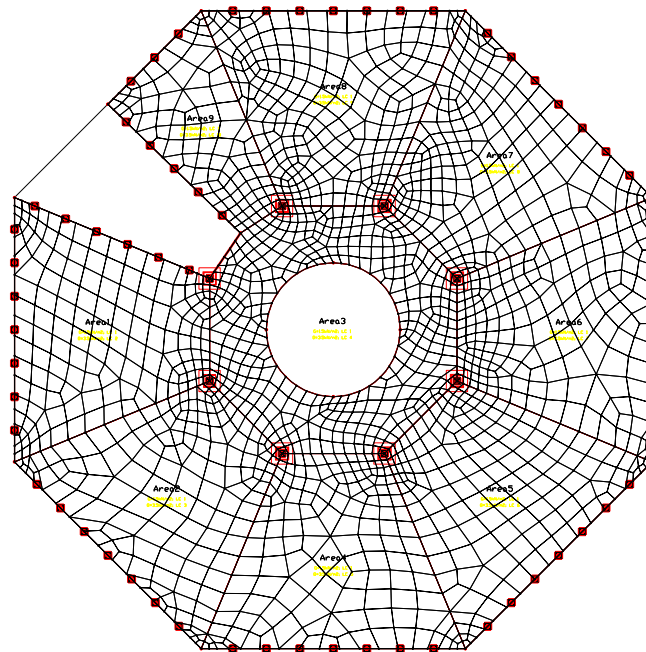

5.11 ANALYSIS



ICON: Analysis
MENU: SOFiPLUS→Analysis...
Command: SOF_G_NUMOUT

In the beginning analysis process requires to specify which output results are going to be computed.

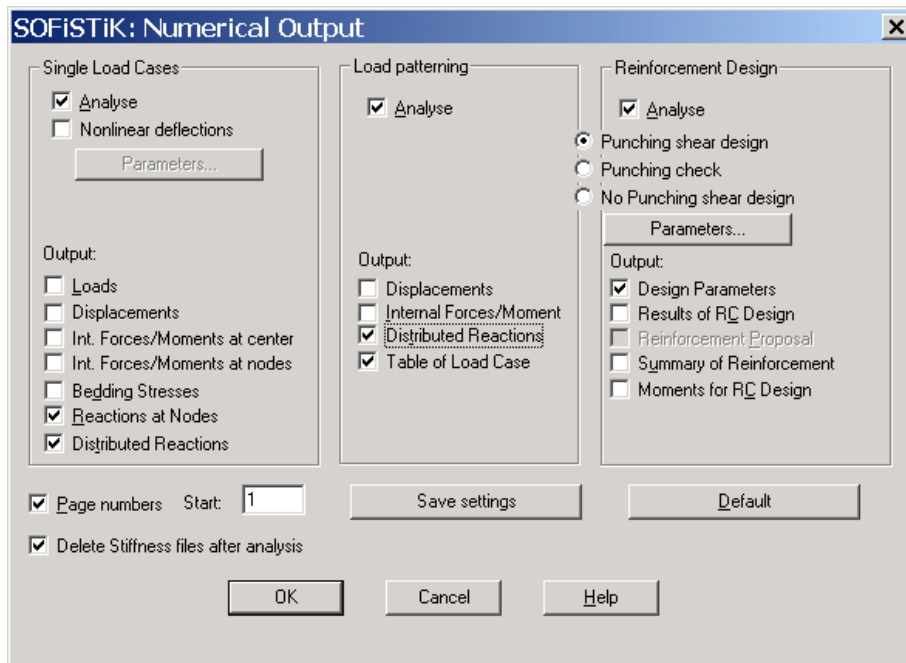

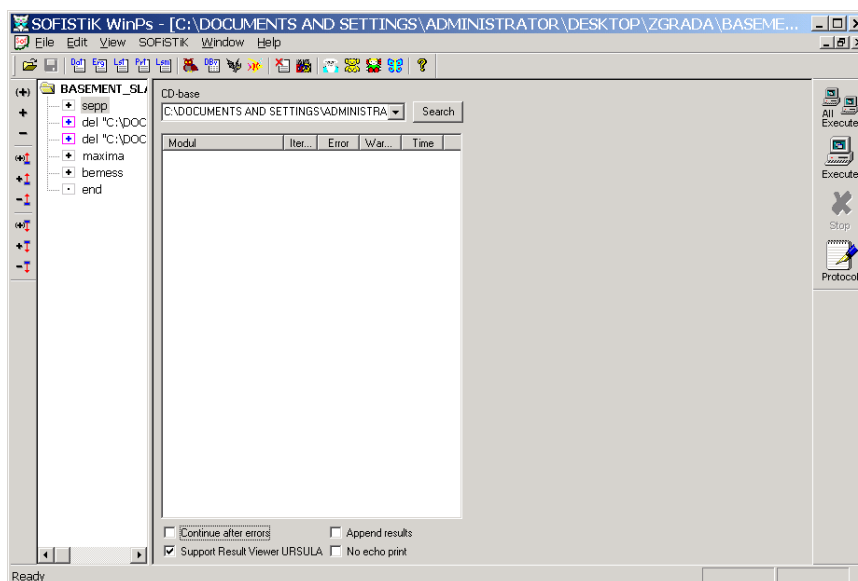

By marking the check boxes certain options are activated. For example, to display reactions check the *Load patterning* check box. Static calculation is performed in WinPS working environment.

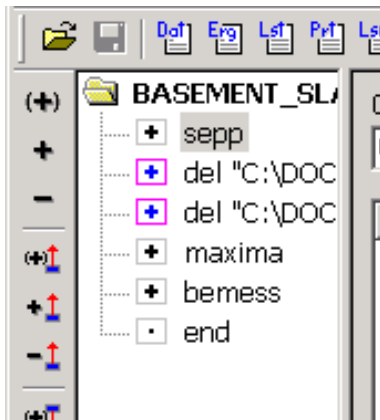

WinPS working environment enables full control over the calculation process. Certain modules can be switched on or off.



By clicking on the *Execute*, analysis process of the structure starts. Particular error or warning signs appear in front of the module names signaling probable problems and abnormalities during execution.

Modul	Iter...	Error	War...	Time
 sepp		0	672	50
 maxima		0	0	7
 bemess		0	2	13

User should pay attention on the messages and analyze them with URSULA.

5.12 GRAPHICAL PRESENTATION OF RESULTS

SOFIPLUS disposes of powerful tools for graphical presentation of the results. One of the tools is GRAFICAL OUTPUT.



ICON: Graphical Output

MENU: SOFiPLUS→ Graphical Output→Graphical Output...

Command: SOF_G_GRAOUT

When calling up this command offers two options.

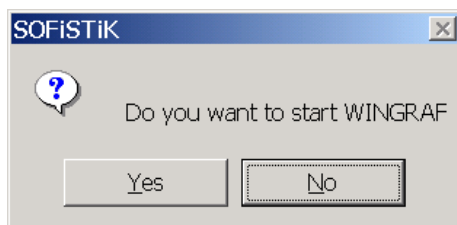

To start WINGRAF and iterative creation of drawing book, and All drawings are defined in advance and the book is automatically created.

In this example second option is picked (click on No). *Graphical Output* dialogue box contains couple tabs which allow appointment of particular drawing parameters for structure, deformations, static values and reinforcement.

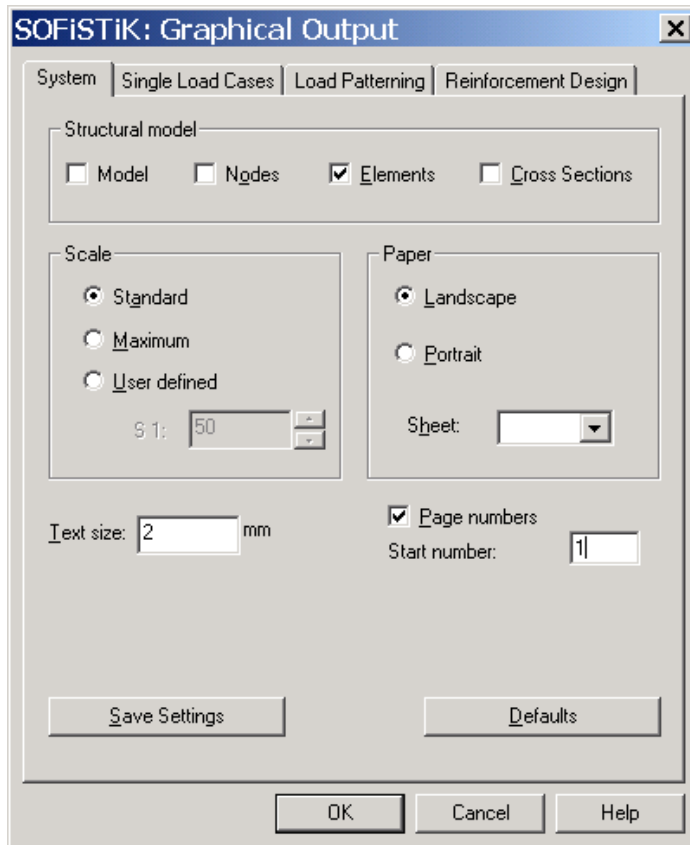

The first tab *System* serves for selecting of structural elements which are going to be displayed on the drawing. Also scale, paper layout, text size and starting page number is adjusted on this tab.

Single Load Cases and *Load Patterning* tabs determine which static values are going to be drawn and the way they are going to be displayed (numbers, contours, colored surfaces).

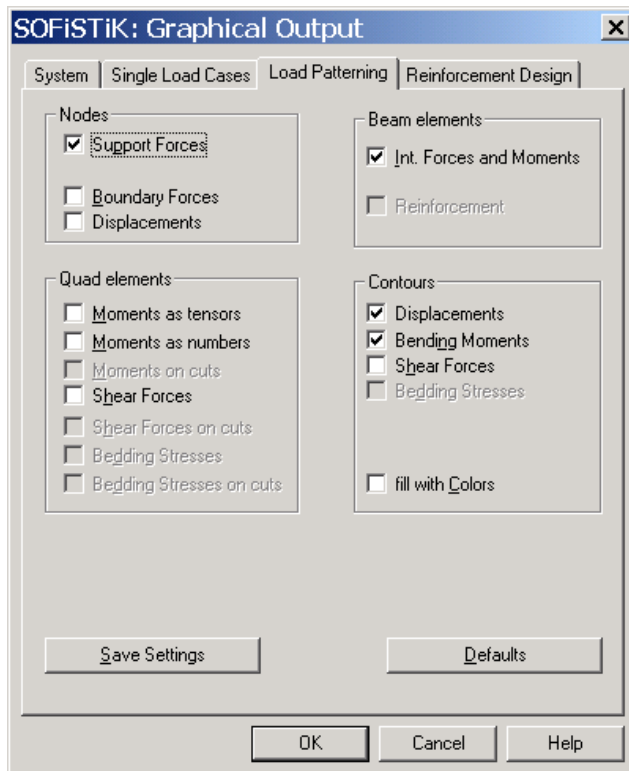

The difference between them is in applying the options on all load case. Such case is Load Patterning and Single Load Case defines each load case separately. *Reinforcement Design* is used to define the mode of displaying reinforcement in slab elements.

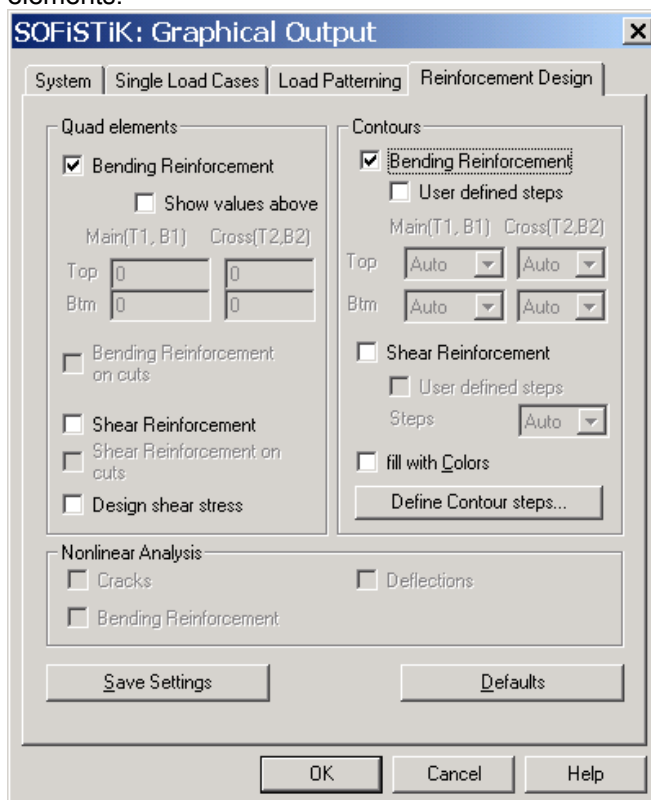

When *Graphical Output* dialogue box is closed, WinGRAF module is started automatically and drawing book is created. When WinGRAF finishes the procedure, URSULA is started and allows review of the drawings.

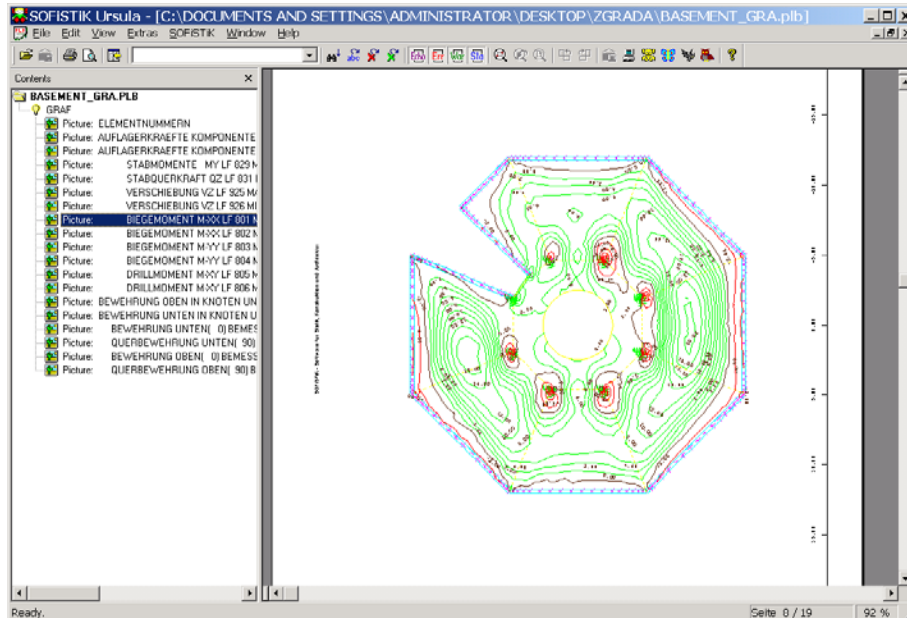

URSULA working environment is divided on two parts. In the left part contents of the book is shown and on the right part selected page in the list is displayed.

5.13 VIEW AND PRINT RESULTS

SOFiPLUS creates several resultant files. Review of the files can be done by the following command:



ICON: View and print
 MENI: SOFiPLUS → Tools → View and print
 Command: SOF_G_TYPED

In the file list select the file you want to review or print.

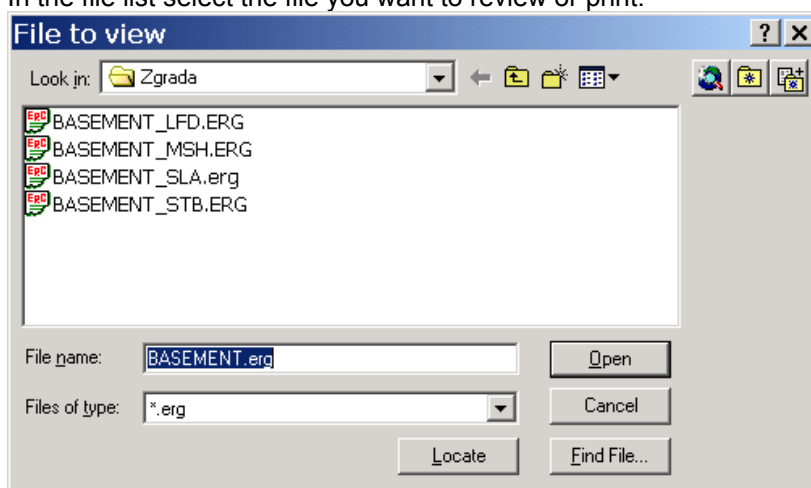

For example, if you select BASEMENT_MSH.ERG file, finite element mesh file data is opened.

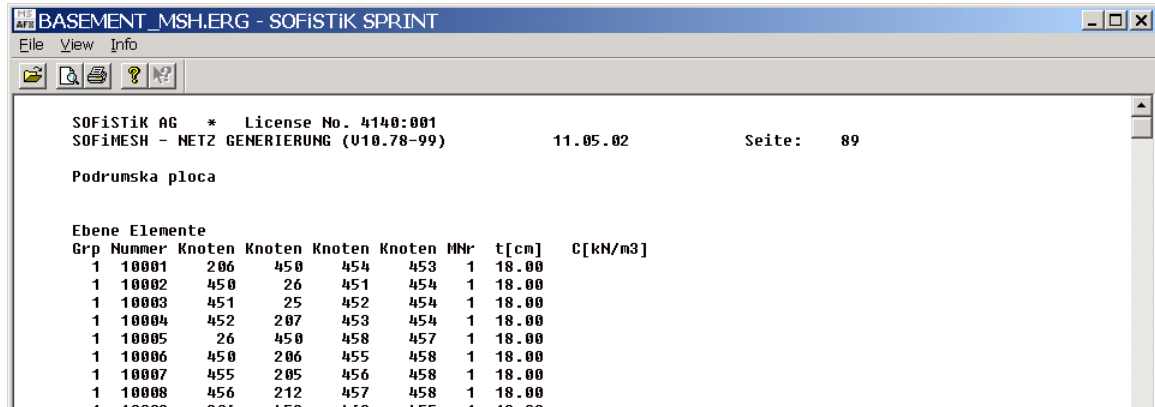

Other files in this example are:

- BASEMENT_LFD.ERG – load data
- BASEMENT_SLA.ERG – load coefficient data
- BASEMENT_STB.ERG – beam dimensioning data

It is interesting to make a comparison between different models of a structure. To be able to see the differences between models the same slab structure is examined, but the columns are molded with point supports and the reinforce concrete walls with fixed supports. To indicate other SOFiPLUS possibilities few changes in molding the slab around staircase are made.

First by command:

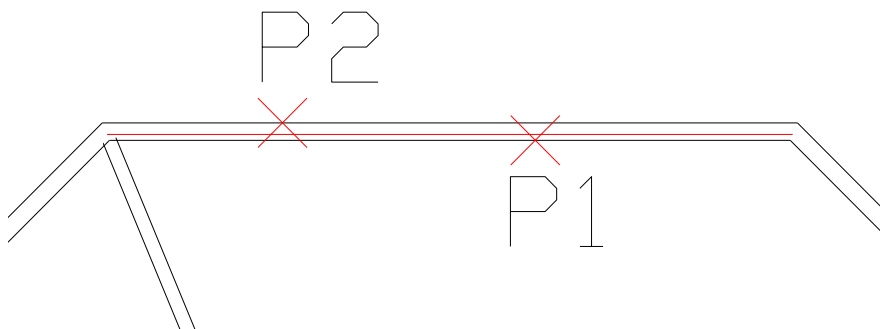

ICON: 1/3 Line
MENU: Soils→Defined model→Auxiliary Line→1/3 Line
Command: SOF_DRITTEL-LINIE

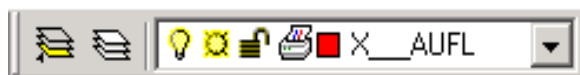

structural lines of inner walls of the slab are drawn.
 Those structural lines are placed on layer: X_AUFL

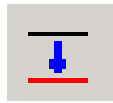

With AutoCAD command *Line* lines are drawn between columns and between columns and walls. Those lines, using AutoCAD command *Match Property* or using the command:



ICON: Copy to structural Layer
 MENU: SOFiPLUS→Defined model→Auxiliary Line→S Copy to structural Layer
 Command: SOF_DRITTEL_LINIE

are transferred on layer X__AUFL and are transformed in structural lines.

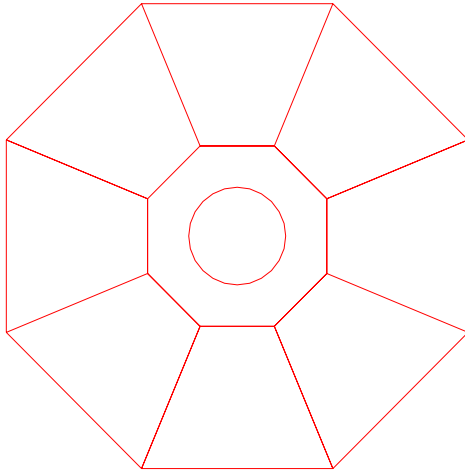

By the command:



ICON: Structure area
 MENU: SOFiPLUS→Defined model→Structure area
 Command: SOF_PM_AREA

structural areas are created and by the command:



ICON: Opening
 MENU: SOFiPLUS→Defined model→Opening
 Command: SOF_PM_HOLE

opening in the center of the slab are formed. Thereby parameters for the slab and loads are entered: Geometry ($d=18$ cm) and Loads (Dead load 1.5 kN/m² and Impulse load 3.5 kN/m²). In the next steps several modifications of the area 8 are made, with the purpose of adapting it according the staircase.

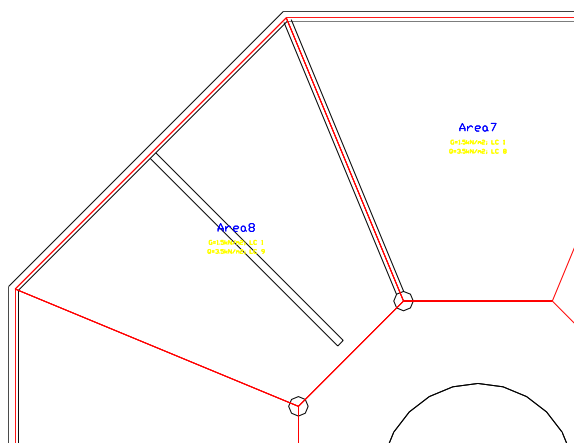

First two edge lines are going to be divided on two parts.



ICON: Split edge
 MENU: SOFiPLUS→Modify model→ Split edge
 Command: SOF_M_EDGE_SPLIT

Command: SOF_M_EDGE_SPLIT
 structural edge (end+mid+int+nea): mid
 of
 pick Point on edge (end+mid+int+nea) or [First point]: mid
 structural edge (end+mid+int+nea): Return

As a result structural edge is divided on two parts and at intersection point new structural point is inserted. Likewise, outward structural edge is divided on two parts. New structural edge is drawn, connecting both new created points.



ICON: Structural edge
 MENU: SOFiPLUS→Define model→Structural edge
 Command: SOF_PM_EDGE

This new structural edge divides area 8 on two parts. SOFiPLUS recognizes new closed contours and transforms them in structural areas. *Loads on Areas* dialogue box is opened automatically to enter loads for the new area.

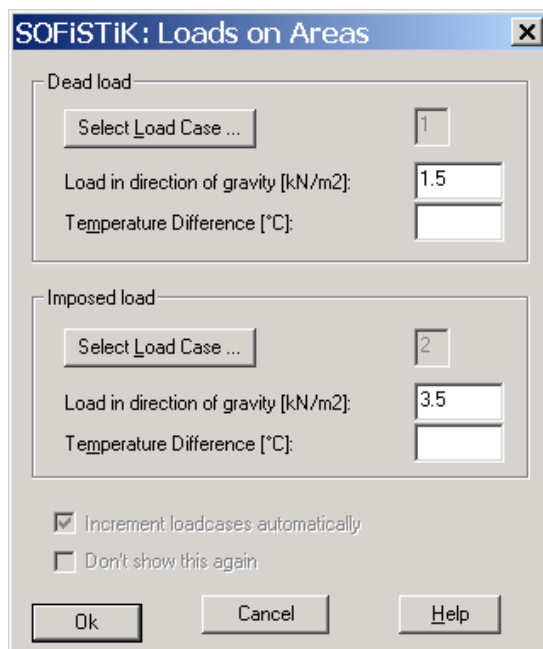

Starting the command SOF_PM_EDGE a dialogue box opens and new characteristics of edge lines are entered. This line should represent fixed support or support which can accept vertical reaction and moment. To input these characteristics open *Support conditions* tab and mark boxes in front of PZZ and MX.

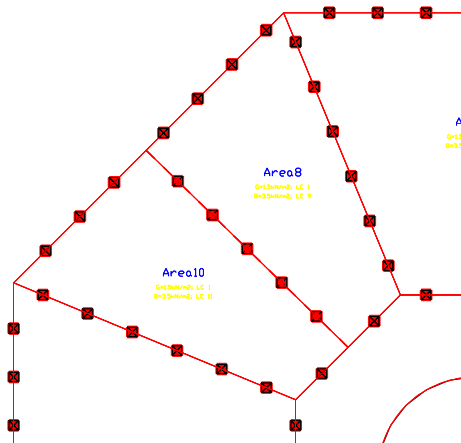
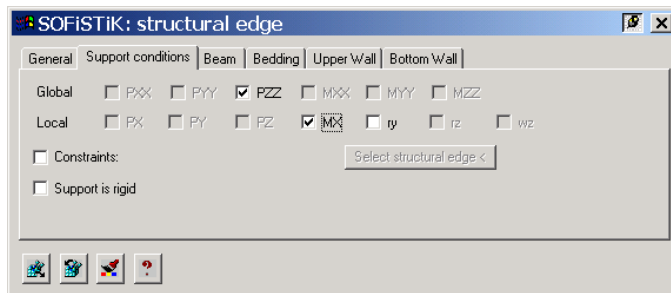

Area 8 is supernumerary. There is no slab in that area and it should be deleted. Deletion is done by simple AutoCAD command *Erase*. One more modification has to be done. Lower edge lines of areas 9 and 10 should be moved to adjust on the architecture of the structure.

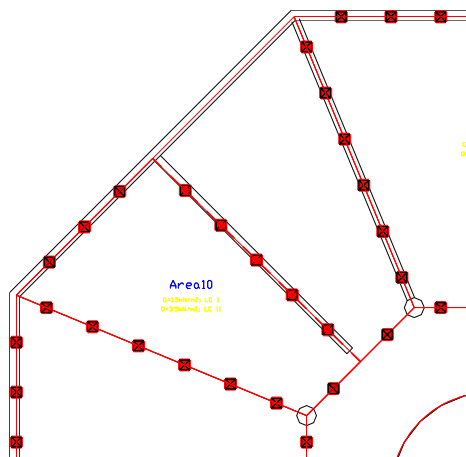

Use AutoCAD command *Stretch* to move point P1 to P2.

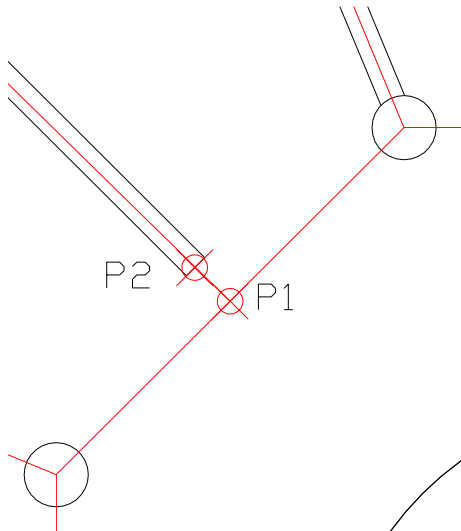

When slab areas are formed, edges are freely supported.

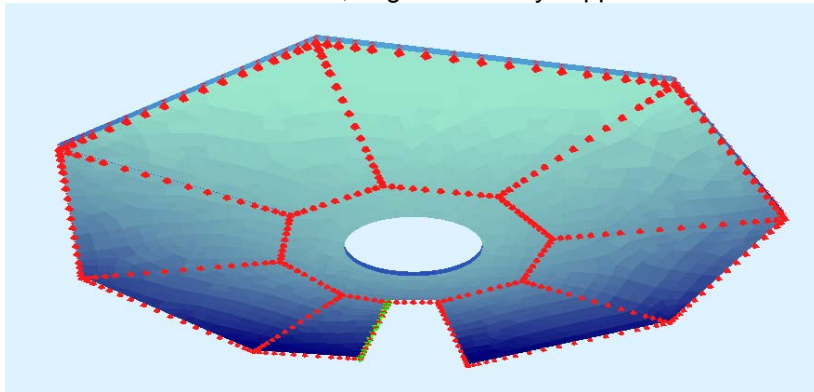

In this example, inner edges should be restrained from displacement in Z direction and contour edges should be transformed in fixed supports.



ICON: Modify Structural Edges
 MENU: SOFiPLUS→Modify model→Structural Edges
 Command: SOF_PM_EDGE_M

First select the inner edges and check the PZZ box.

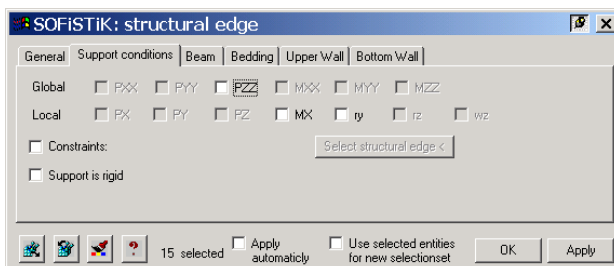

In the next step contour edges are transformed as fixed.

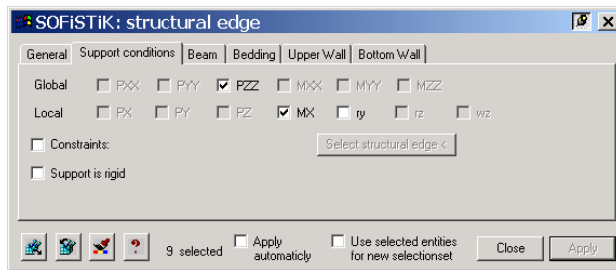

At the end edge between inner reinforced concrete walls is replaced by reinforced concrete beam with cross section ($b/h = 25/50$).

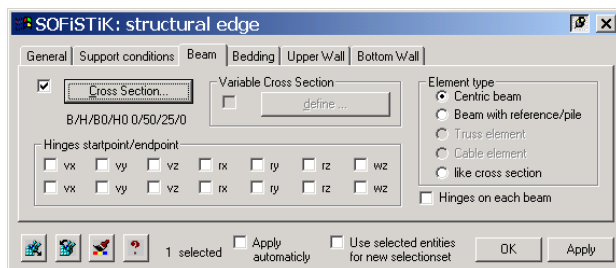

Further columns has to be entered. As stated before, in this example, columns are replaced with point supports (restrained displacement in Z direction).



ICON: Modify Node
 MENU: SOFiPLUS→Modify finite element→Node
 Command: SOF_GKNOTMOD

Select support nodes and in the *Support conditions* tab check PZ box to restrain displacement.

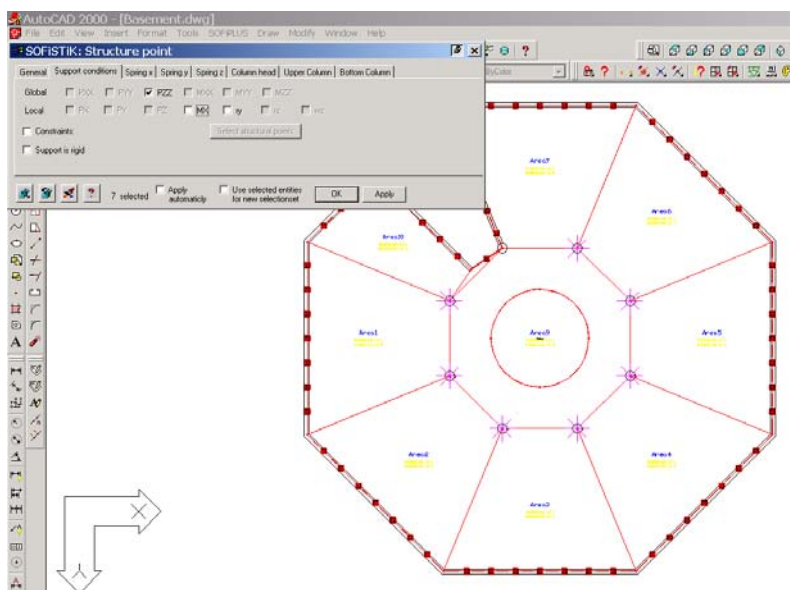

Final look of the mathematical model is shown in this picture.

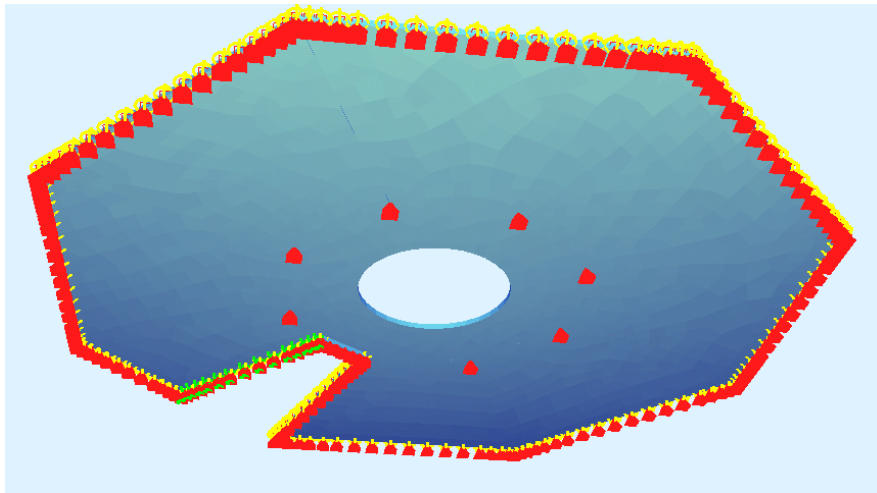

The remaining steps in the analysis (finite element mesh generation, analysis, graphical presentation of the results) are the same as previous model and are not repeated here. Typical differences in both models are in points above columns and contour edges. Therefore, make two sections through these points and compare the results. Results are graphically presented in WinGRAF.



ICON: WinGraf
MENU: SOFiPLUS→Graphical output→Graphical Output...
Command:

Start new sheet in WinGRAF.



ICON: New Sheet
MENU: Edit→New Sheet

On the new sheet structure contours with supports are drawn. Draw two cut lines to view bending moments.



ICON: Create Cut
MENU: Edit→Cuts→Create

Command:
Create cuts above Area Element
From point: (Click on the first point of the line)
To point: (Click on the last point of the line)

Two lines are drawn: first passes above the column and the second between columns. Results are drawn using following command:



ICON: Draw Results
MENU: Select→ Draw Results...

In the dialogue box select:

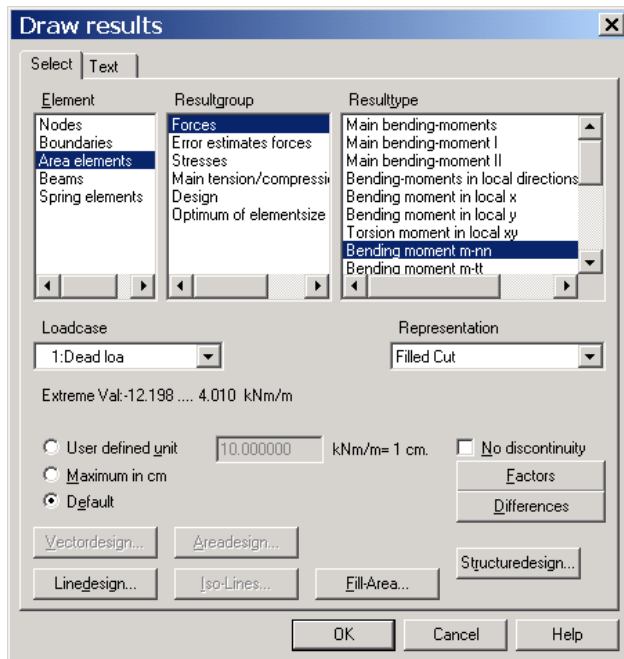

Element Area elements
 Resultgroup Forces
 Resulttype Bending moment m-nn
 Representation Filled Cut
 Loadcase 1: Dead load

Normal moments are drawn on the sheet. To get the best view zoom the area around lines.



ICON: Box
 MENU: Select → Box

Command:

Choose Box.1 Corner: (Draw rectangle to represent new view port on the drawing)

Bending moments along both cut lines for both models are presented:

Columns molded with elastic springs:

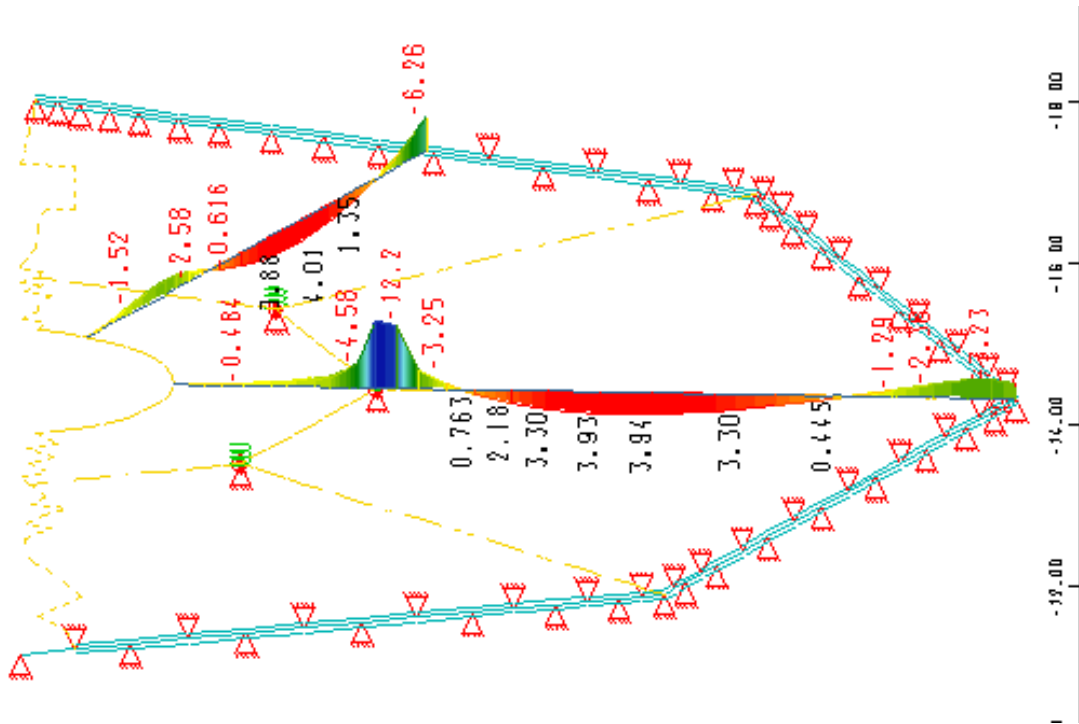

Columns molded with point supports:

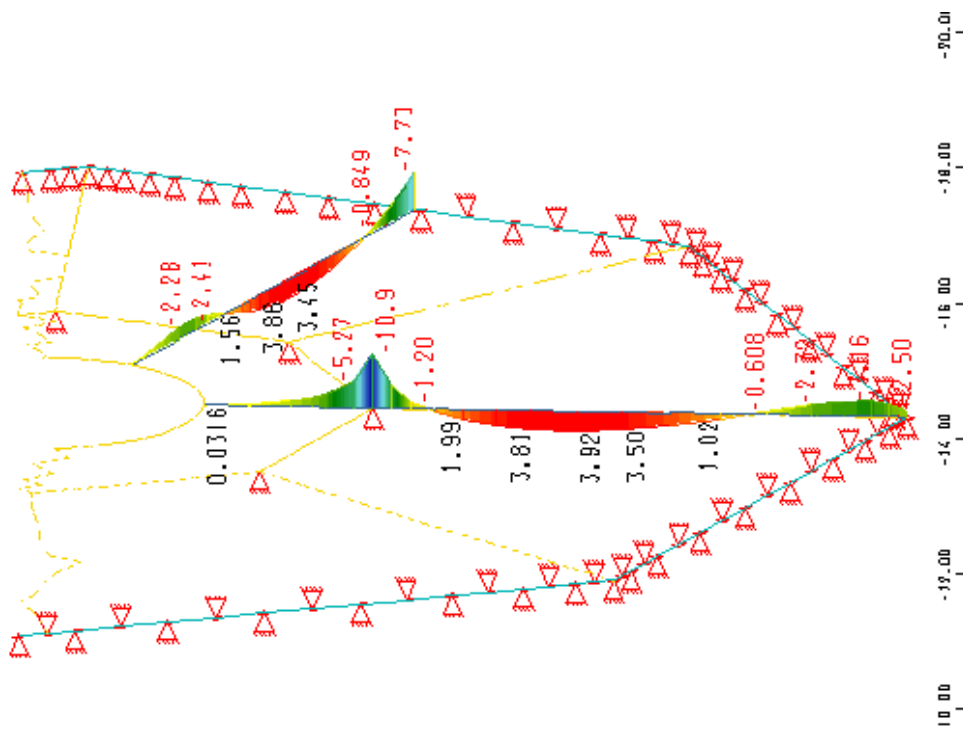

Twice dense finite element mesh:

Columns molded with elastic springs:

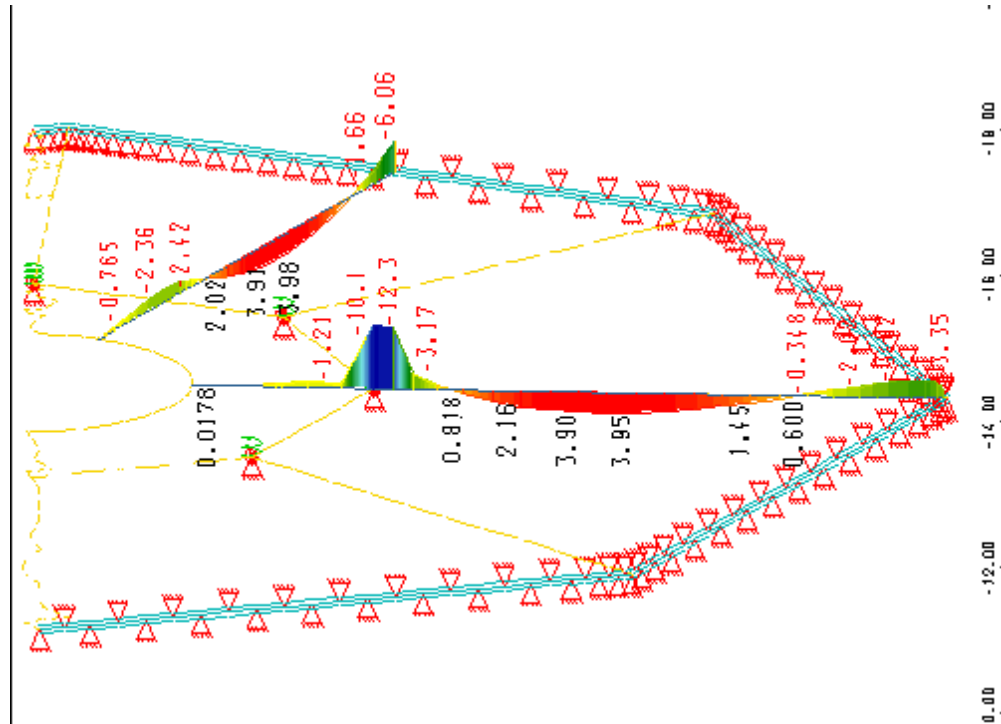

Columns molded with point supports:

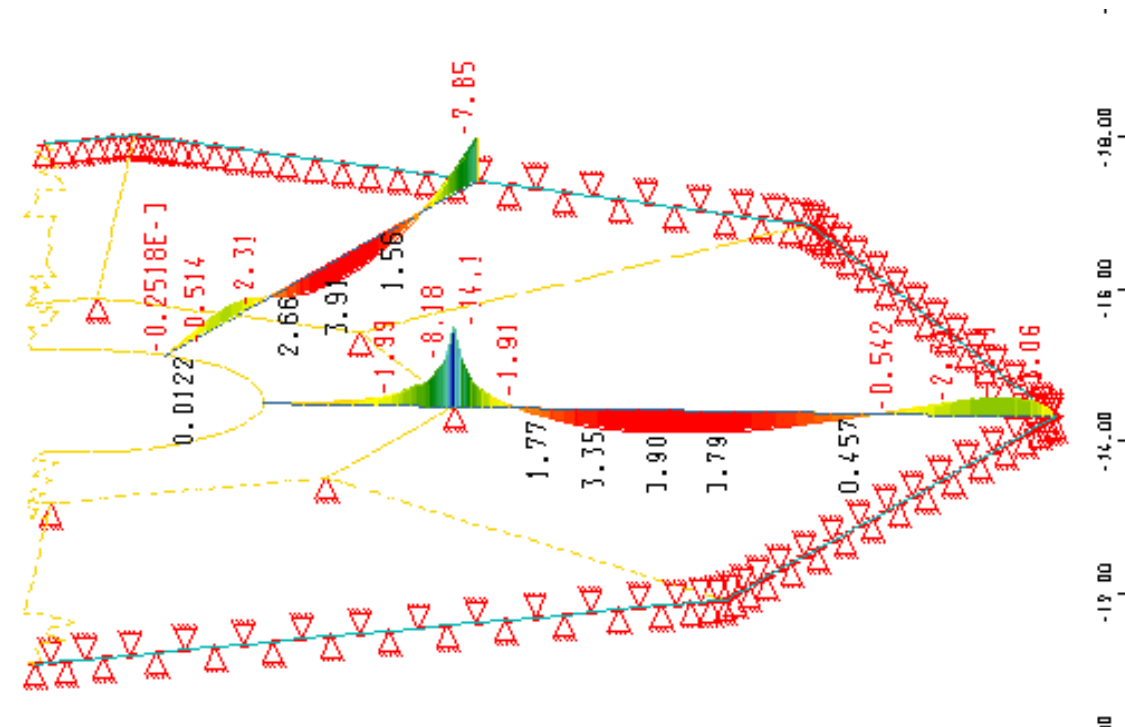

COMMENT: Model with the elastic springs shows lower dependence from mesh density. At point model, owing singularity of the moments, moment values at supports are increasing as far as finite element size is decreasing.

6. Example 3 : Platform II

This is a further extension of EXAMPLE 2:

Geometry of platform II is shown on following sketches.

Grid & Column Distribution

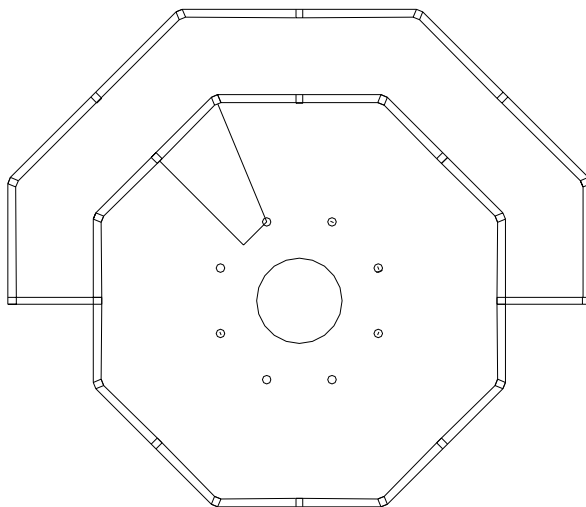

Central part has girder-less roofing supported on circle columns. Roofing on its contours is supported on reinforced concrete beams placed over rectangular columns. Central part of the slab has circle opening. Staircase area is designed as Platform I.

6.1 AutoCAD preparation

Finite element mesh will be created by AutoCAD objects. For this purpose user should knowledge about have basic AutoCAD functions for creating 3D surfaces. Main purpose of this example is to present SOFiPLUS possibilities without taking care about optimal solution and critical attention to finite element mesh.

It is recommended to create several auxiliary layers for lines, surfaces and etc. This style in preparation process, provides bigger control over the drawing.

Several auxiliary lines are drawn in this preparation phase. This lines should create closed rectangular areas (rectangular edges may not be straight). They are placed on layer named POMOSEN. 3D surface is created for each element. In this example following AutoCAD command is used:



ICON: Edge surface

MENU: Draw→Surface→ Edge surface

Command: RULESURF

This command creates surface by moving one line over two other lines. This command has two variables: TUBSURF 1 and TUBSURF 2. This variables define mesh density in both slab directions.

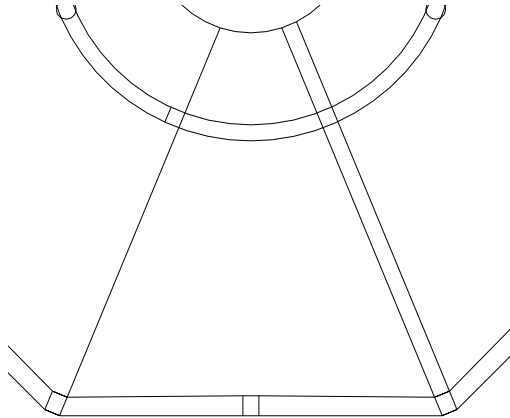

In the applied method for creating finite element mesh, size of the variables defines mesh density.

First finite element mesh for central array is generated. Divided parts have density of 9 parts in longitudinal and transverse direction.

Command: SURFTAB1

Enter new value for SURFTAB1 <8>: 9

Command: SURFTAB2

Enter new value for SURFTAB2 <2>: 8

Now, generation of surface is done. Surface edge selection schedule is shown on the picture.

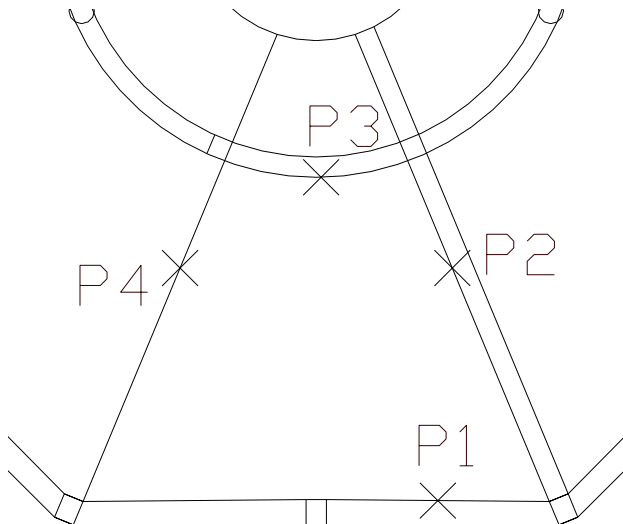

Command: `_edgesurf`

Current wire frame density: SURFTAB1=9 SURFTAB2=8

Select object 1 for surface edge: (click on point P1)

Select object 2 for surface edge: (click on point P2)

Select object 3 for surface edge: (click on point P3)

Select object 4 for surface edge: (click on point P4)

First surface has been created.

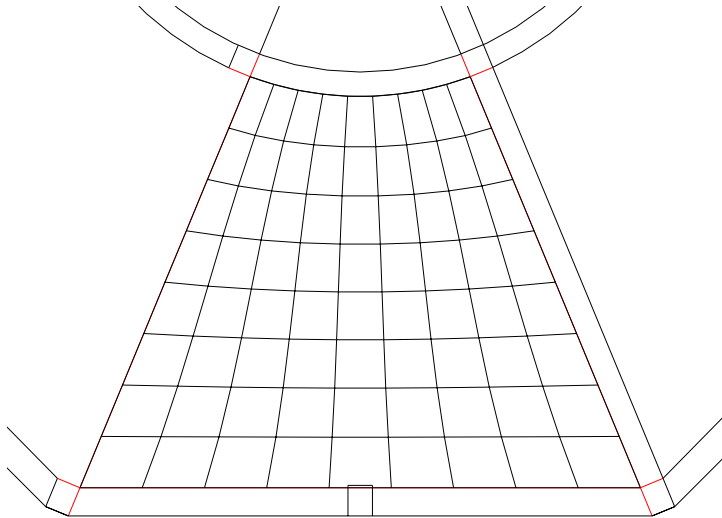

In the next step second surface over the lower beam is formed. You should be careful on the edge division number which merge to remain the same. Thus, same division of parts are used in longitudinal direction and only variable that defines divisions in transverse direction of the beam is changed. (minimal possible number 2 is used).

Command: SURFTAB2
Enter new value for SURFTAB2 <8>: 2

Surface edge selection plan is shown on this picture.

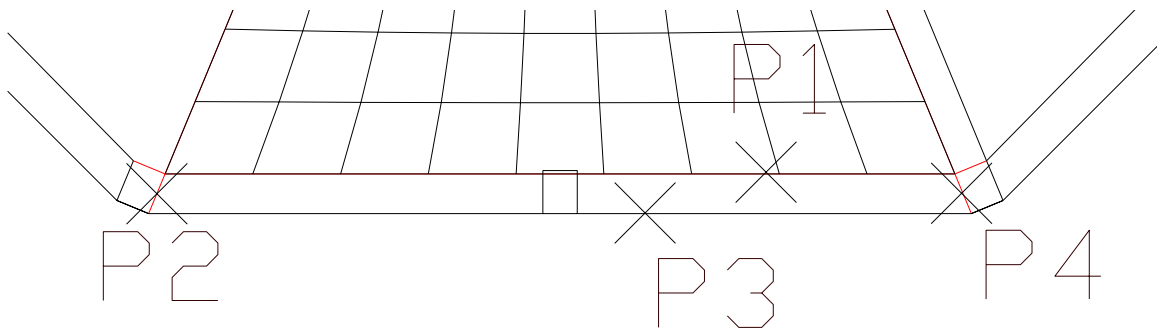

Second surface has been created.

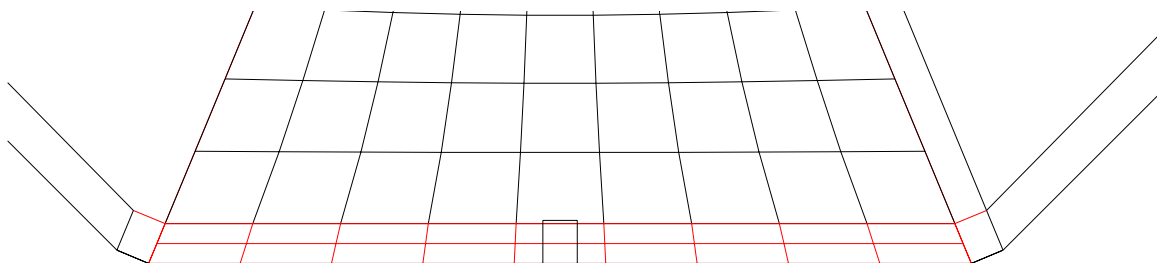

This process continues until all characteristic surfaces of the segment are created.

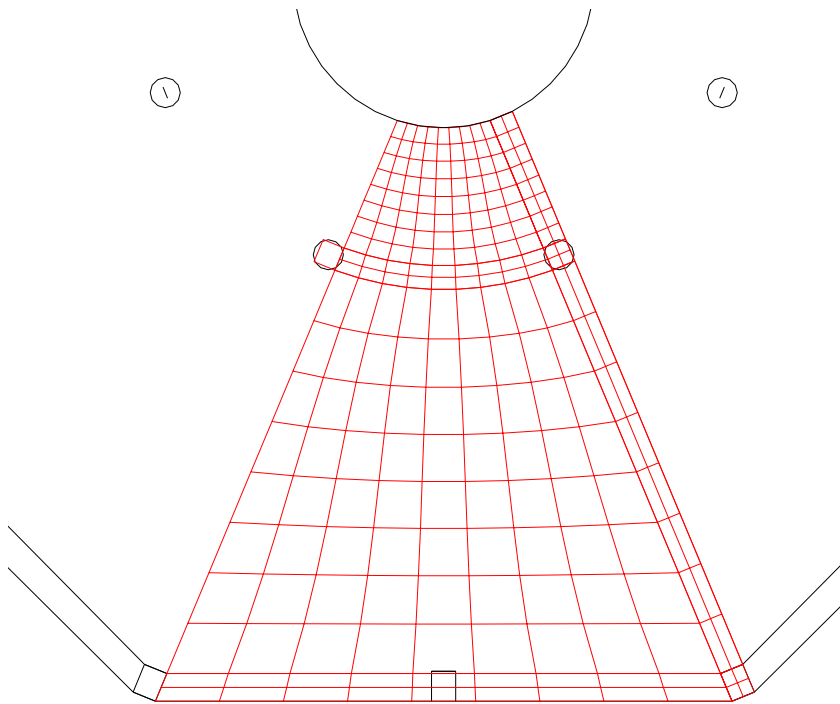

Base segment is regular octagon, created from eight equivalent segments. The remaining segments of the slab will be formed by copying them with circle array.

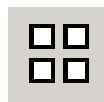

ICONA: Array
MENU: Modify→Array
Command: Array

Command: **array**
Select objects: 1 found
Select objects: 1 found, 2 total
..... (select all surface segments)
Select objects: **Return**
Enter the type of array [Rectangular/Polar] <R>: **P**

Specify center point of array: **_cen of**
Enter the number of items in the array: **8**
Specify the angle to fill (+=ccw, -=cw) <360>: **Return**

Rotate arrayed objects? [Yes/No] <Y>: **Return**

RECOMMENDATION: It is useful to close all layers except surface and central circle layer, before using *Array* command. Auxiliary lines should be precisely drawn, so inspected segment is supposed to represent 1/8 of circle.

As a result of *Array* command whole central surface is covered with surfaces.

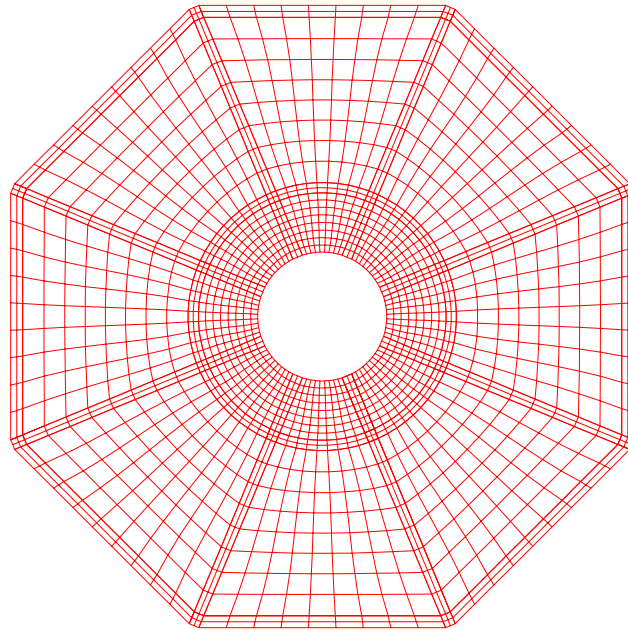

6.2 CREATION OF FINITE ELEMENT MESH

Finite element mesh is created by using AutoCAD objects (surfaces):

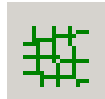

ICONA: Generate with objects
 MENU: SOFiPLUS→Generate→With Objects
 Command: SOF_GNETGEN

In the dialogue box

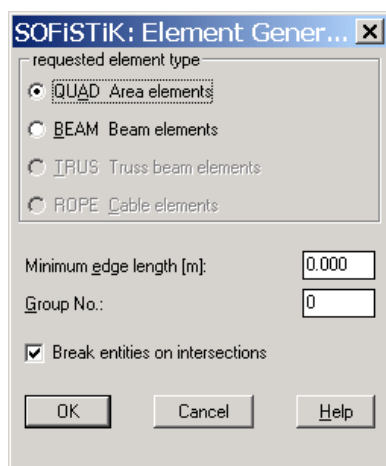

select QUAD (quadrilateral area elements are generated). If you specify value for *Minimum edge length*, only smallest element size is will be defined. This is usually used for filtration, in case some small elements are not supposed to be taken in the mesh. Created elements may be located in a groups (*Group No.* option). *Break entities on intersection* should be checked in order to acquire line intersection nodes. Program itself searches for intersection nodes on lines, arches and polygonal lines, generates node points and creates finite elements between

these node points. Merging lines are not taken under consideration. A message like this pops up,

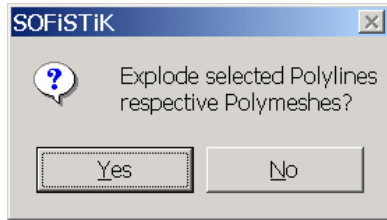

to determine if polygonal lines and meshes are going to be deleted from selected set (answer Yes). Generation is finished after answering the question about first element number to be generated with this task.

Select objects:

.....
 First Element number<1>: **Return**

Searching intersections
 Treating partial-lines ...
 Making Elements ...

6.3 CREATING FINITE ELEMENT MESH USING MACROS

SOFiPLUS offers several possibilities for creating finite element mesh using macros. Quadrilateral areas can be created combining different lines and points.

Positive side in generating finite element mesh using macros is creating the mesh directly without using auxiliary lines. Node points which are previously generated on edges, are recognized by a macro and for those edges information about number of elements are not needed.



ICON: 1/3 Line
 MENU: SOFiPLUS →Generate→With Macros
 Command: SOF_G_DOL

With this command user can create quadrilateral, beam, truss or cable elements. Selection is done in the dialogue box which is called up after this command.

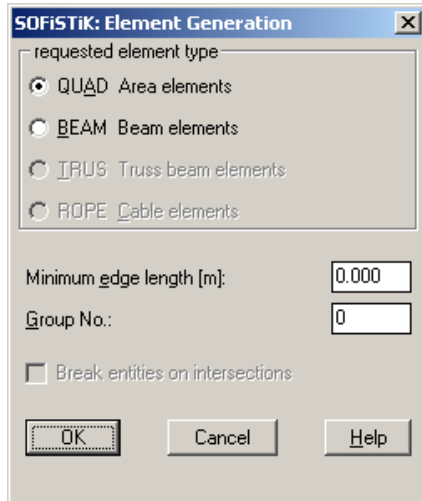

In this example, slab system is examined, therefore TRUSS (Truss beam elements) and ROPE (Cable elements) are not available. First finite element mesh is created in the slab area which lies over the column using the option 4Lines.

Command:

Determine input order <4Lines>[4Lines/3Lines/2Lines/1Pt 2lines/2Pts 1line/4Points/Element type/Help...]:

1. Pick line: (select first column line)
2. Pick line: (select second column line)
3. Pick line: (select third column line)
4. Pick line: (select fourth column line)

If lines are selected correctly, SOFIPLUS marks the contour

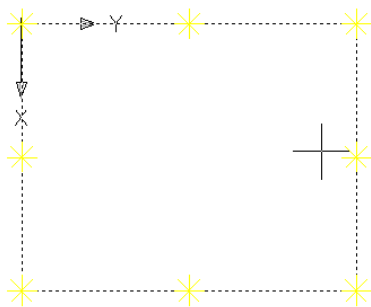

and asks user for verification of desired geometry:

Geometry as desired? [<Yes>/No]: Y

In the next step mark the rectangle edge to input number of elements to be created on the edge. In this example, one element is adopted for the first edge.

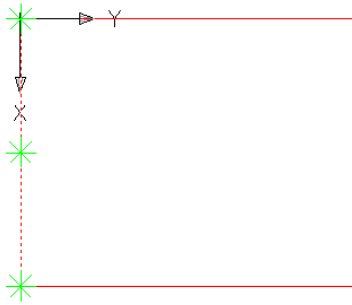

Enter number of elements: **1**

Next edge is marked to input number of elements.

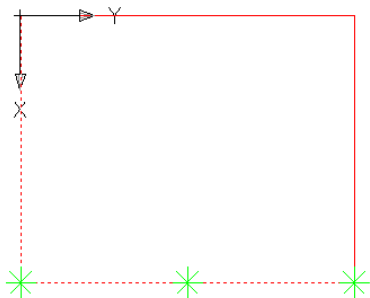

Enter two elements for this edge.

Enter number of elements<1>: **2**

Enter number of the elements for the remaining two edges. After that SOFiPLUS displays messages to enter odd and even number of elements.

Enter odd number of elements<1>: **Return**

Enter even number of elements<2>: **Return**

At the end enter the first element number from the group to be created.

First Element number<1763>: **Return**

Mesh created for the selected edges is shown on the following draft.

Finite element mesh for beam element is also created by macro command. Other option is used: *2Lines*

Command:

Determine input order <4Lines>[4Lines/3Lines/2Lines/1Pt 2lines/2Pts
1line/4Points/Element type/Help...]: **2L**

1. Pick line: (select upper beam edge)

2. Pick line: (select downward beam edge)

Geometry as desired? [<Yes>/No]: **Y**

Enter number of elements<6>: **6** (number of elements of the upper edge)

Enter even number of elements<6>: (number of elements of the downward edge)

In this case SOFiPLUS recognizes previously defined elements on other two edges and accepts that number.

First Element number<1765>:

Finite element mesh in other parts of the structure can be created by objects or macros. This procedure is already described in previous lines, so only final look of the mesh is presented.

6.4 CORRECTIONS IN FINAL ELEMENT MESH

In the actual structure opening is present in the center, where staircase is situated. In the mathematical model final elements in that area have to be erased. Deletion is done by simple AutoCAD command *Erase*. Click on the *Erase* button and click to select all elements to be erased. After deletion mathematical model looks like the one on the picture.

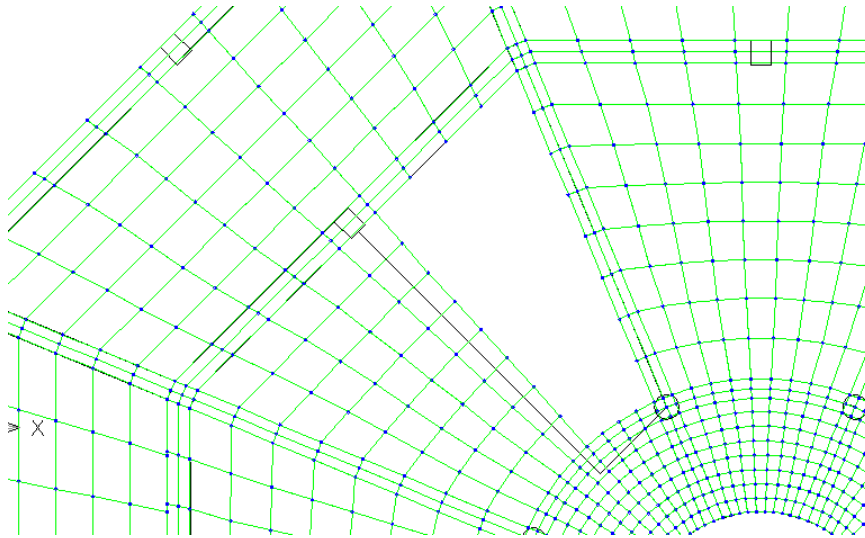

During finite element mesh creation, on few edges elements of neighboring areas do not match.

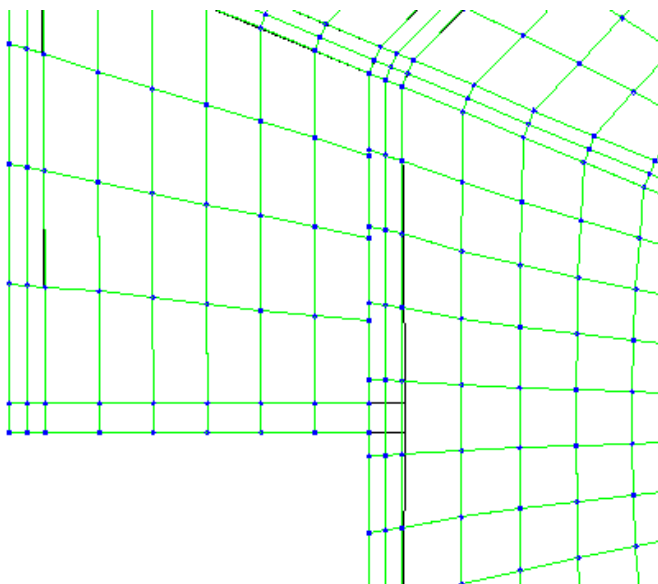

Points from both meshes have to be compatible. For this purpose, AutoCAD commands *Move* and *Stretch* are used. First move the points P1, P2 and P3 to match points P1 and P4.

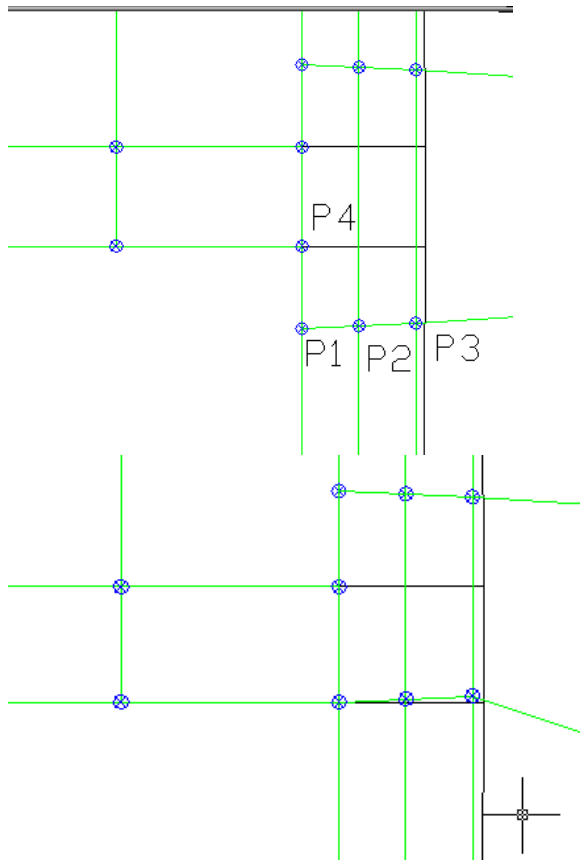

On the same way points from the slab where no matching of elements on neighboring areas are present, are modified.

6.5 CONSTRAINTS

CONSTRAINTS stands for connecting several points to reference point, so that points have same deformation as reference point. In this example points from the contour are connected with the point in the center of the column (reference point).

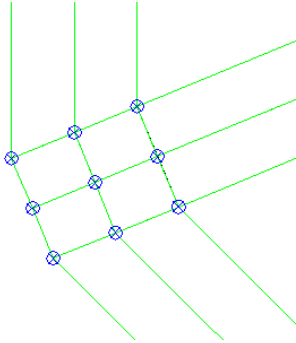

ICON: Constraint

MENU: SOFiPLUS→Create Finite Element→Constraint

Command: SOF_GKOPP

Command:

nodes to couple

Select objects: (select contour points of the column)

Reference node (end+cen+nod+int+ext): (select center point of the column)

Type of constraint [KPZ/KMX/KMY/KP/KL/KQ/KF]: **KP**

(KP match by all deformations of the slab)

nodes to couple

Select objects: (continue with other points where CONSTRAINTS has to be entered)

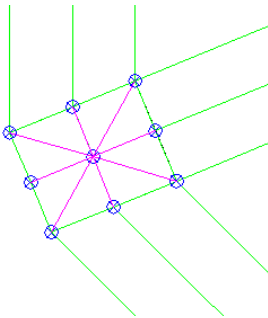

During finite element mesh creation with commands *Generate With Objects* or *Generate With Macro*, node points in the mesh are freely supported. Displacement of the reference point on the column should be restrained. Use *Modify Node* or *Info/Edit*. In this example first command is used.



ICON: Modify Node

MENU: SOFiPLUS→Modify Finite Element→Modify Node

Command: SOF_GKNOTMOD

In the following dialogue box

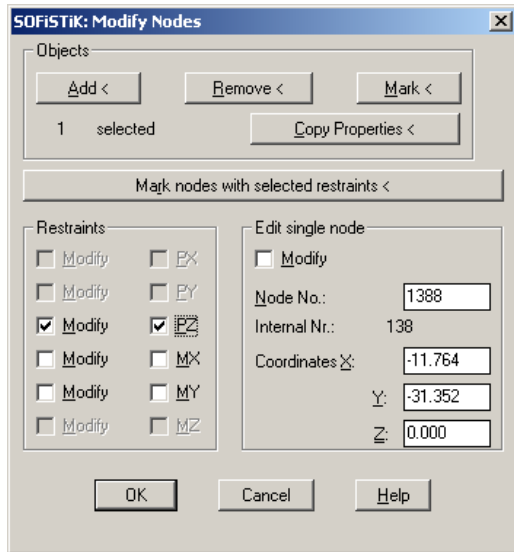

mark PZ check box to restraint node to move in Z direction, namely to accept vertical reaction.

When reference point is set, it can be deleted from the drawing. If reference point is not already created, you can create it with previous command.

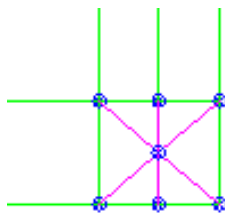

← New created point

By doing this, deformations for contours are connected with center points of the columns in the structure.

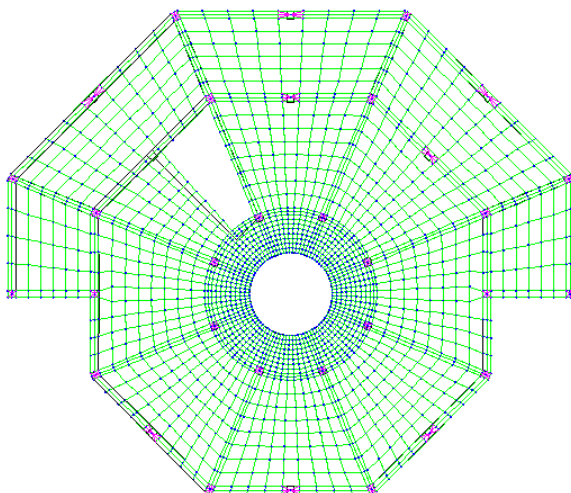

6.6 BOUNDARY ELEMENTS

Boundary elements are used for line supports. User enters first and last point of the line support. Automatically all nodes which lay on that line are recognized by the program and prescribed deformations are applied. If line supports have to be entered on circle arch, nodes are entered one by one.



ICON: Boundary Element

MENU: SOFiPLUS→Create Finite Element→Boundary element

Command: SOF_GRAND

Command:

First node of boundary element (end+mid+nod+int):
(click on point R1)

Last node of straight boundary element (end+mid+nod+int):

(click on point R21)

Support direction [CZ/DX/DY/DN/DT]: **DN**

Spring constant at start in kN: **15000**

(Rotational stiffness of the wall in point R1)

Spring constant at end in kN<15000.0000>:

(Rotational stiffness of the wall in point R2)

Name of boundary element: **Bound1**

Connect found intermediate node? [<Yes>/No]: **y**

Select additional intermediate nodes

(additional nodes are not entered)

First Boundary element No.<1>:

First node of boundary element (end+mid+nod+int): **Return**

Refer. point (end): **Return**

Few types of constraints of the contour elements are possible:



If *Name of boundary element* is not entered, program inputs blank name to avoid errors in static program. All reactions contained in this line support in the program for static calculation are distributed along support length.

Line support for second wall at the staircase is created on same way.

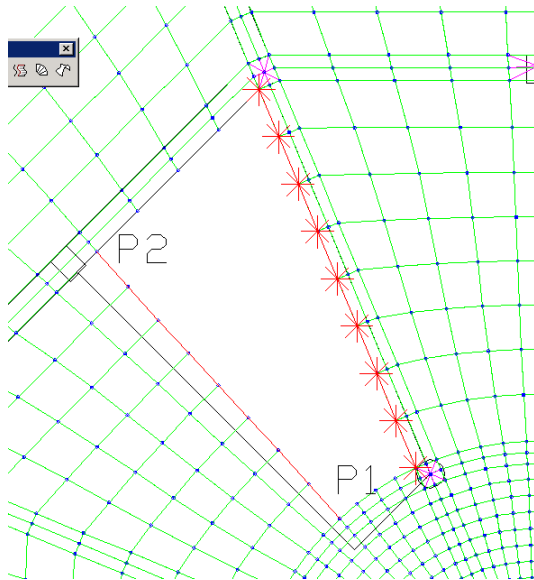

Constraint type DN creates elastic rotation along the line. Limited vertical displacement should be added to this displacements. Using *Info/Edit* or *Modify node* vertical displacement in nodes along the line support should be constrained.

6.7 BEAM ELEMENTS

On the outward contour of the hallway, slab is supported on beams. Those beams have to be entered in the model.



ICON: Beam
 MENU: SOFiPLUS→Create Finite Element→Beam
 Command: SOF_GSTAB

Command:

Start node (end+mid+nod+int): (Start node of the beam)

End node (end+mid+nod+int): (End node of the beam)

Connect marked intermediate node? [<Yes>/No]: Y

(Intermediate points between start and end node are recognized by the program)

First Beam No.<1>: 1

Section number<1>: 2

Start node (end+mid+nod+int): (Continue with other beams)

Beam elements passing above outward columns in central slab are created in the same manner.

6.8 MODIFYING THICKNESS OF AREA ELEMENTS

Area elements created by objects or macros have equal thickness as assumed (in this example 20 cm). Usually this thickness is not equivalent to real and should be changed. Modification is done using *Modify Area Element* or *Modify Area Element Variable*. First command is used whenever modification is permanent at whole selected slab area and the second command when slab has variable characteristics (variable thickness, placenta and etc). In this example, slab thickness should be changed to 18 cm.



ICON: Modify Area Element

MENU: SOFiPLUS→Modify Finite Element→Area Element

Command: SOF_GQUADMOD

After activating this command, elements to be modified have to be selected. In the example, select all area elements. After selection, enter slab thickness 0.18 m in Dim edit box.

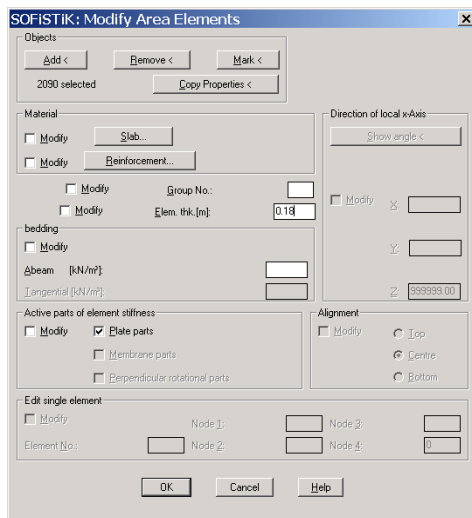

To control input data use following command:



ICON: Info/Edit

MENU: SOFiPLUS→Info/Edit...

Command: SOF_GINFO

to display element information for clicked area.

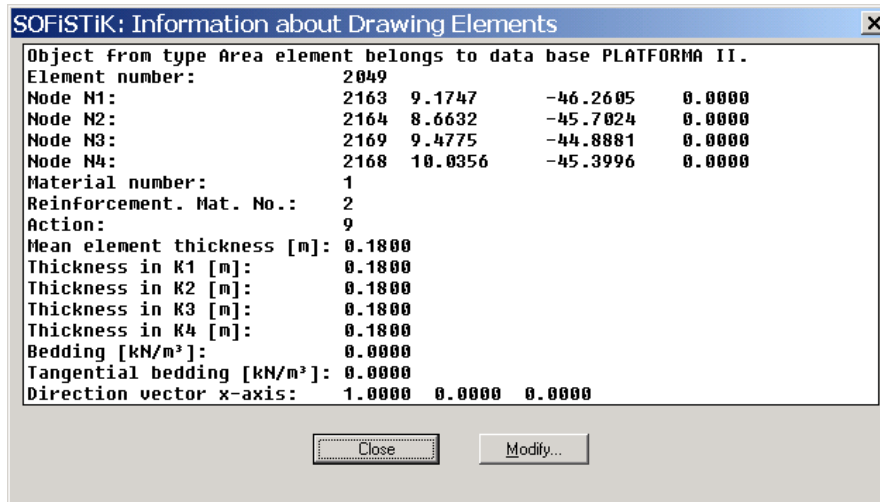

6.9 LOADING

During finite element mesh generation by objects or macros, load cases are not automatically created. First use *Loadcase Manager* to define load cases and then apply all loads acting on the slab.



ICON: Loadcase Manager
 MENU: SOFiPLUS→ Loadcase Manager
 Command: SOF_GLFMOD

Two load cases are analyzed.

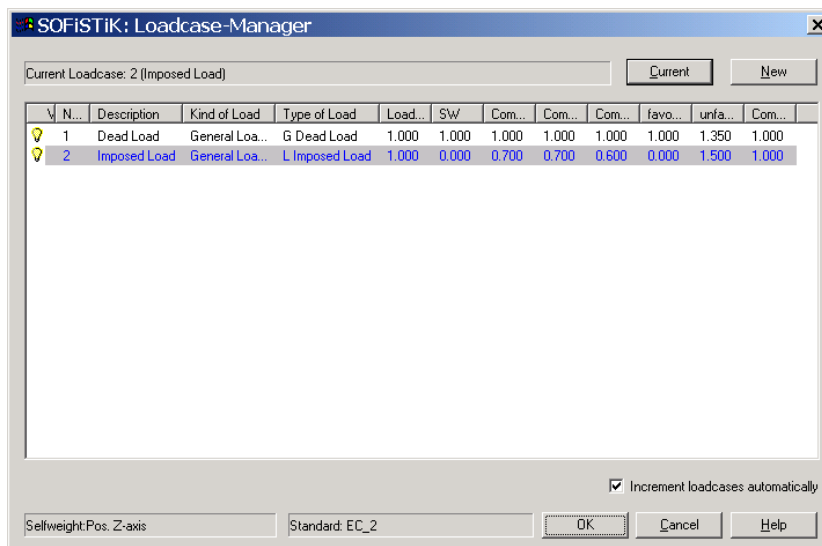

Enter SW factor 1.00 for the first load case. It indicates that for this load case self weight of elements is automatically calculated and participates 100% in defining loads. As a result of other loads which act on the slab, it should be loaded with additional load of 2.00 kN/m². To enter this load, make first load current in *Loadcase Manager*. Select first load case and click on *Current* button.



ICON: Free Area
 MENU: SOFiPLUS→Create Loads→Free Area
 Command: SOF_GBLAS

Enter load parameters in the dialogue box.

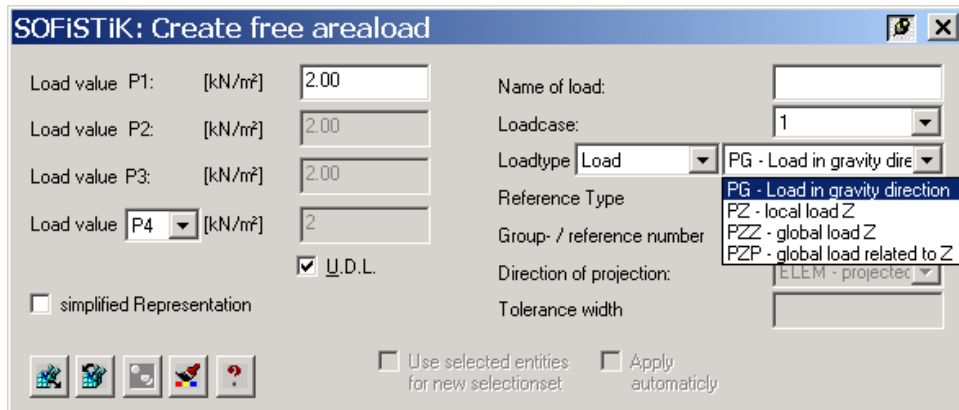

U.D.L. (Uniform Distributed Load) check box is marked so load is uniformly distributed. In the edit text box enter load value 2.00 kN/m². Select load direction in Loadtype combo box as gravity direction. Pick for nodes on the screen to form rectangular area which covers the part of the slab to be loaded. Area may go out of the slab contours and the program automatically computes loads on area elements.

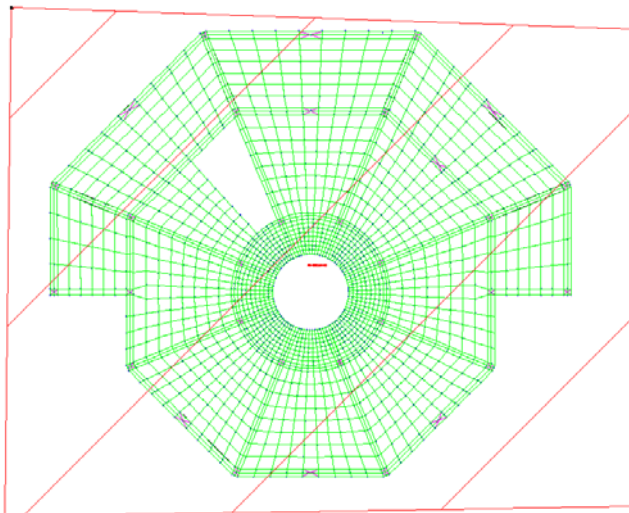

To retain visual control over the process, loading area is hatched. Load area is drawn on layer: X__B001_PLATFORMA II. To preserve bigger visual control over the loading areas it is desirable to close this layer before other loadings are entered for the second load case. For the second load case two uniform loads are entered. Central part is loaded with 7.00 kN/m² and the staircase are with 4.00 kN/m². Make second load case current from the *Loadcase Manager*. Activate *Create Loads→Free Area* and enter load parameters.

SOFISTIK: Create free areaload

Load value P1: [kN/m ²]	<input type="text" value="7.00"/>	Name of load:	<input type="text"/>
Load value P2: [kN/m ²]	<input type="text" value="7.00"/>	Loadcase:	<input type="text" value="1"/>
Load value P3: [kN/m ²]	<input type="text" value="7.00"/>	Loadtype:	<input type="text" value="Load"/> <input type="text" value="PZZ - global load Z"/>
Load value P4: [kN/m ²]	<input type="text" value="7"/>	Reference Type:	<input type="text" value="AUTO - automati"/>
<input type="checkbox"/> simplified Representation	<input checked="" type="checkbox"/> U.D.L.	Group- / reference number:	<input checked="" type="checkbox"/> all
		Direction of projection:	<input type="text" value="ELEM - projected"/>
		Tolerance width:	<input type="text"/>

Use selected entities for new selectionset
 Apply automatically

Command:

pick 1 cornerpoint (end+mid+nod+int) or [Enter polygon]: e
(Loadng area is polygonal)

pick 1 cornerpoint (end+mid+nod+int): (First polygon point)

pick 2 cornerpoint (end+mid+nod+int) or [Undo]: (Second point)

(click all polygon points)

Refer. point (end): **Return**

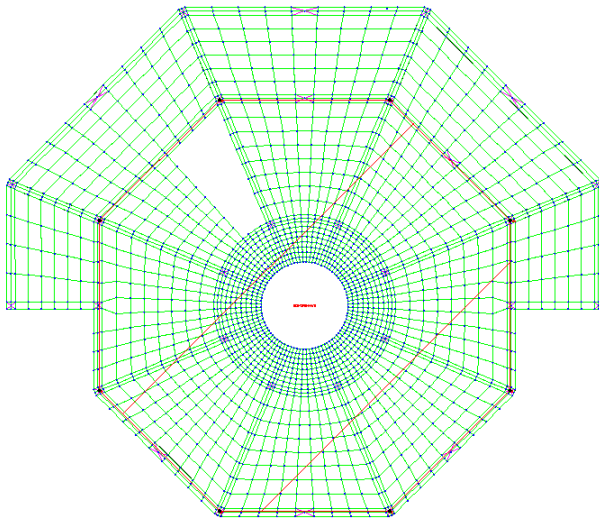

Central part is loaded with uniform distributed load with intensity 7.00 kN/m². Enter hallway load on the same way.

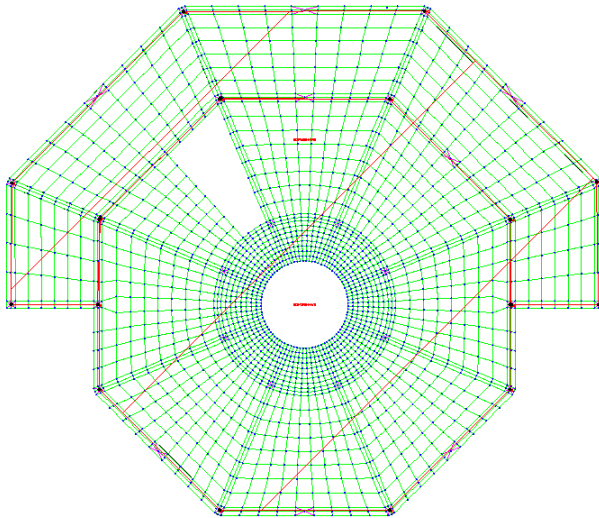

Staircase transport line load on the slab with intensity of 10.00 kN/m².



ICON: Free Line
 MENU: SOFiPLUS→Create Loads→Free Line
 Command: SOF_GLLAS

Enter load parameters on similar style as for area loads.

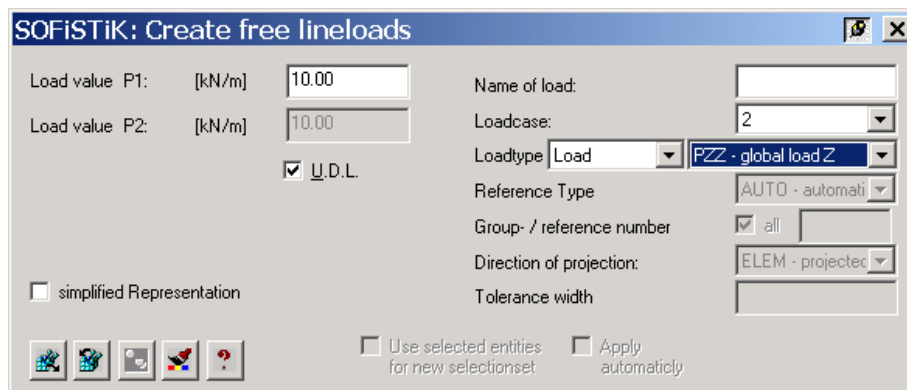

Line load is placed on polygon which covers circle arch at staircase area.

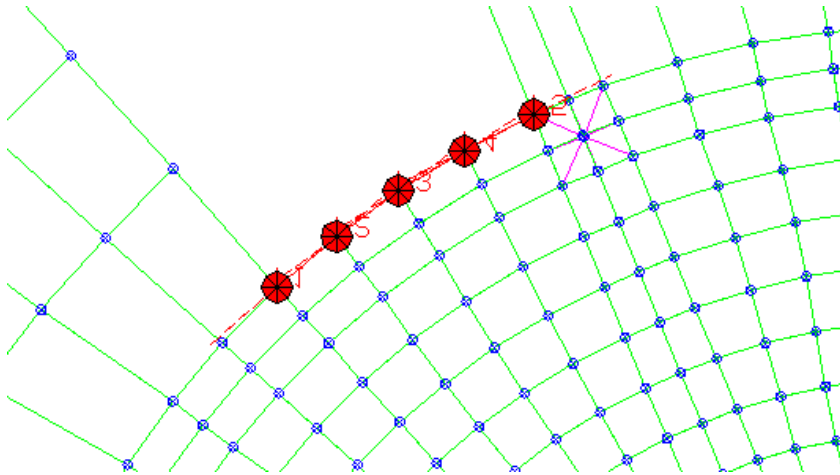

Loads from the second load case are drawn on the layer: X_B001_PLATFORMA II.

6.10 EXPORTING DATABASE

Before running the calculation, element and load data have to be saved in the analysis database. It may be good idea to control database for complex structures.



ICON: Export

MENU: SOFiPLUS→Analyze Data Base (CDB)→Export (.dwg→.cdb)

Command: SOF_GENFIN

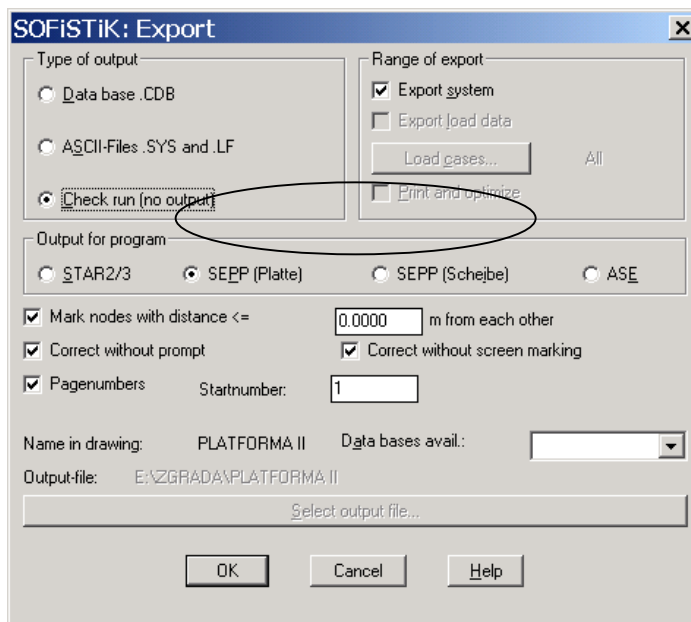

During control some mistakes are eliminated. For example node duplication, deleted nodes from elements are retrieved and etc.

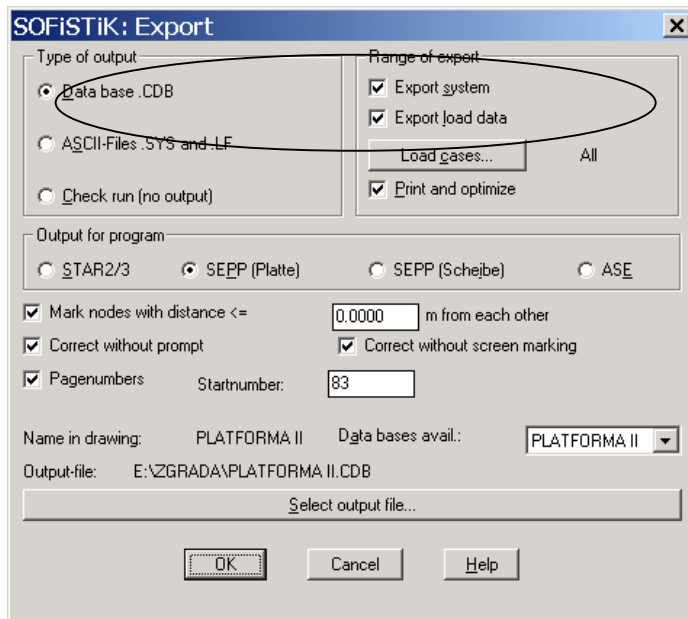

After control is accomplished, database is exported again. Drawing data are placed into the analysis database and ready for further processing.

6.11 ANIMATOR

It is advisable to run visual control of the structure before analysis is performed.



ICON: Animator
Command: Animator

When visual check is under progress, pay special attention on supports.

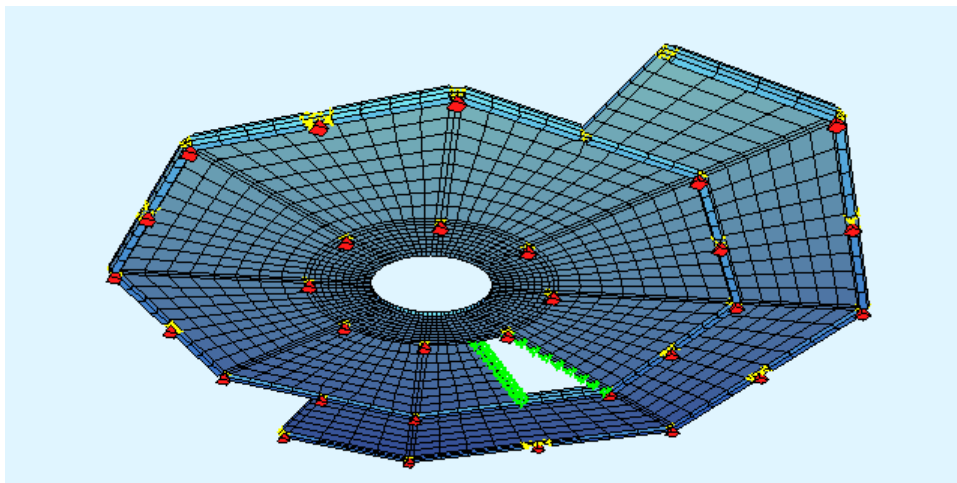

From this control it is obvious that displacements of two columns are not correctly assigned in the mathematical model. Make necessary corrections in SOFiPLUS. Activate following command:



ICON: Info/Edit
 MENU: SOFiPLUS→Info/Edit...
 Command: SOF_GINFO

Select node which is modified.

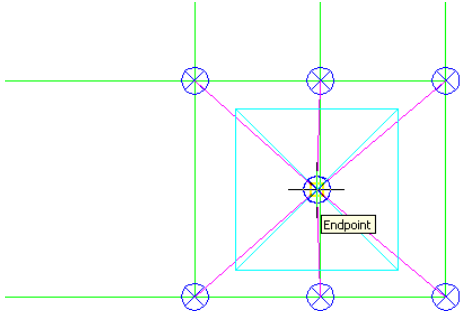

Enter the modification in the dialogue box. Program may not recognize this node point. Click on the *Next* to display all objects which contain selected point. When node is displayed in the dialogue box make the change,

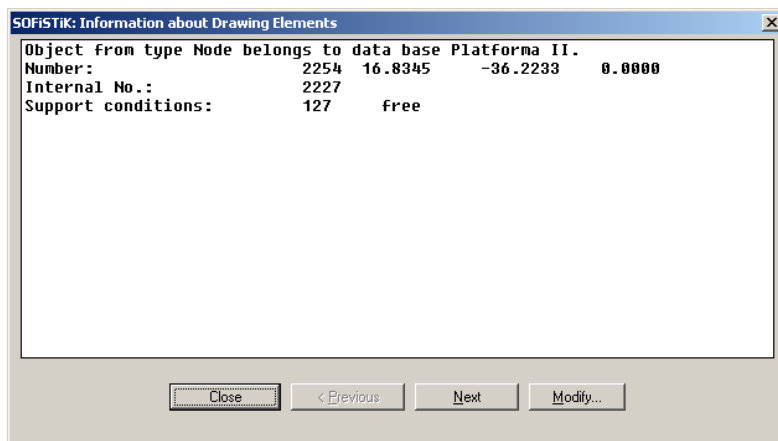

by clicking on *Modify* and enter the changes in the dialogue box.

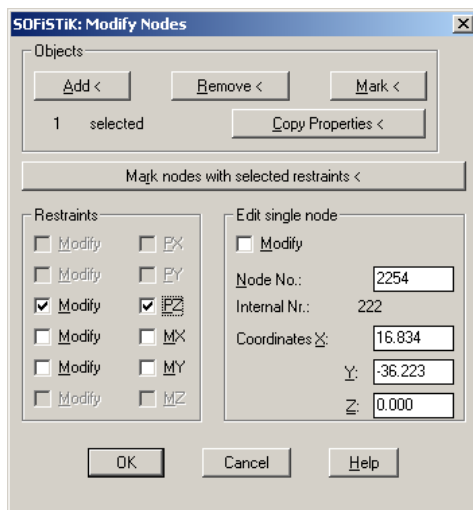

This process continues by changing the characteristics for the second node which has wrong displacements.
After this changes you have to export analysis database again.

6.12 STUCTURE ANALYSIS

Analysis is performed in program WTEDY.



ICON: Edit (Win Ted)
MENU: SOFiPLUS→Analysis ...
Command: SOF_G

Enter the file name in the next dialogue box.

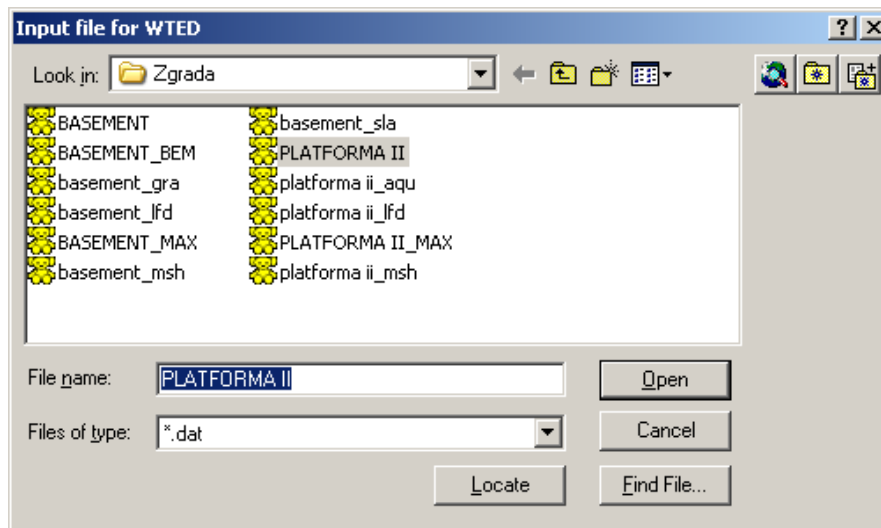

Working area of the Teddy program is displayed on the screen. Any additional data for the analysis which are not contained in SOFiPLUS may be entered. For this example all proposed options are accepted.

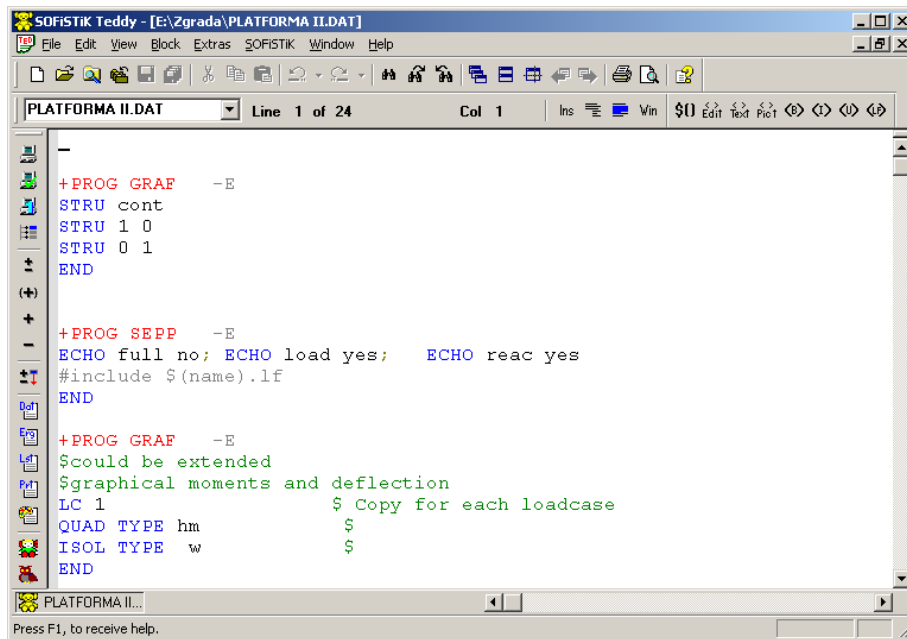

```

+PROG GRAF -E
STRU cont
STRU 1 0
STRU 0 1
END

+PROG SEPP -E
ECHO full no; ECHO load yes; ECHO reac yes
#include $(name).lf
END

+PROG GRAF -E
$could be extended
$graphical moments and deflection
LC 1 $ Copy for each loadcase
QUAD TYPE hm $
ISOL TYPE w $
END

```

Start the program WinPs to begin with the analysis. You have full control over the computation process in WinPs.

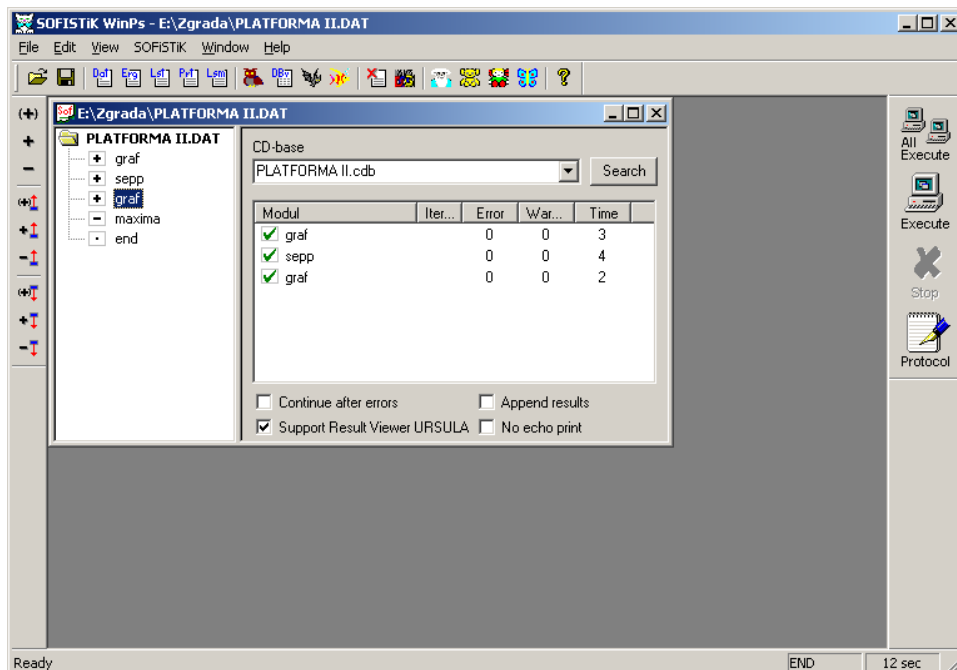

The WinPs interface shows the execution progress of the analysis. The 'CD-base' is set to 'PLATFORMA II.cdb'. A table displays the execution status of the modules:

Modul	Iter...	Error	War...	Time
graf		0	0	3
sepp		0	0	4
graf		0	0	2

Additional options at the bottom include:

- Continue after errors
- Append results
- Support Result Viewer URSULA
- No echo print

The status bar at the bottom indicates 'Ready' and 'END' with a duration of '12 sec'.

Icon *Execute* starts the calculation. If this process finishes without errors, output data files may be created.



URSULA

is used to create output files which contain text and graphic presentation of the results. File contents are predefined. Its contents may be rearranged with friendly Teddy instructions. This

files can not be modified after the analysis. Preview of the files can be done by selecting the file in the left pane of the *Explorer*.

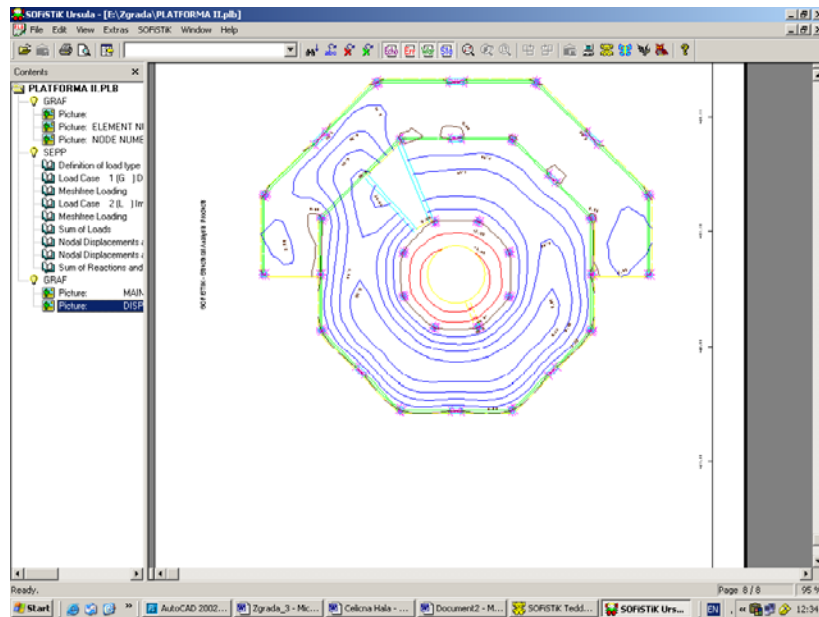

For fast preview of the results, without creation of output files, use Animator and its tools for different visual views.

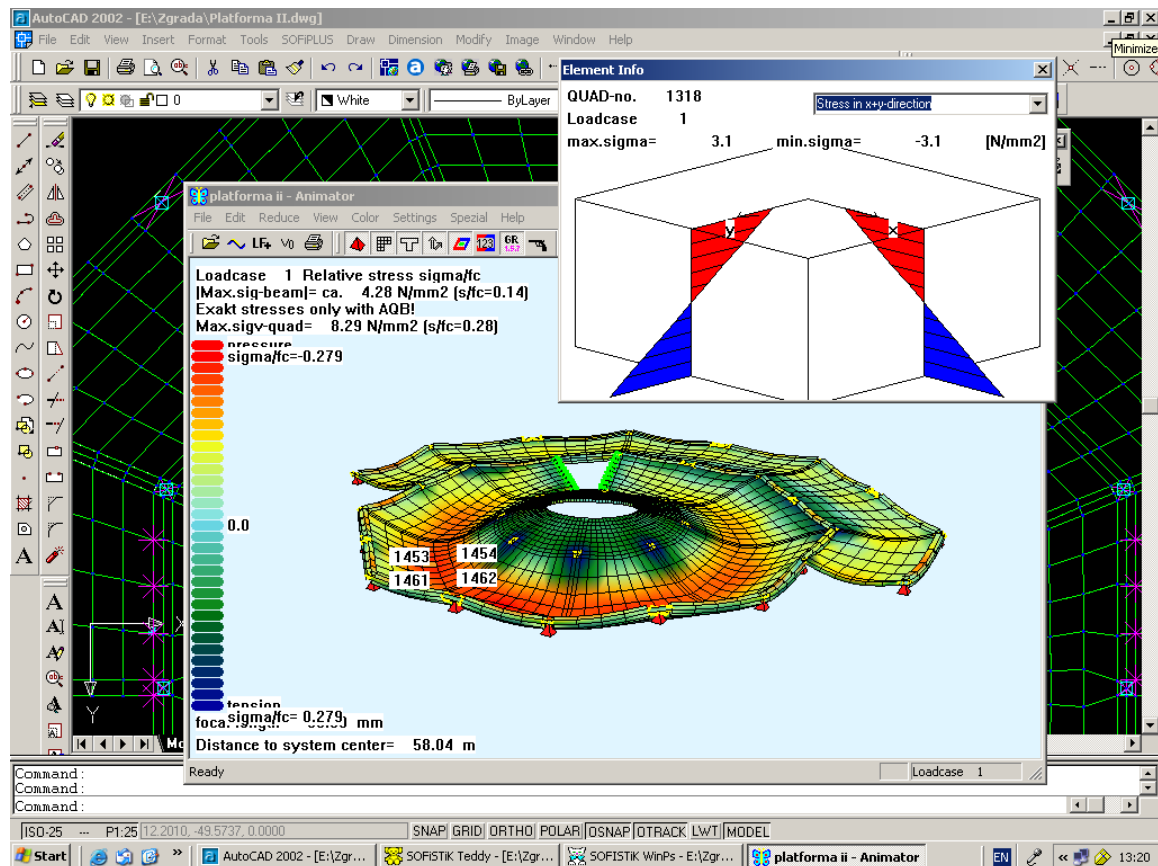

7. Example 4 :ROOF STRUCTURE

Roof structure is consisted of 16 parabolic-hyperbolic segments. The segments are formed by elevating one point from the base for 1 meter. On edges segments are supported by edge beams ($b/h=30/30$). Central part of the structure represents annular slab. Story height is 4 meters. Central columns are circular with diameter $d=40$ cm, while ending columns are rectangular with dimensions of the cross section $b/h=40/40$ cm.

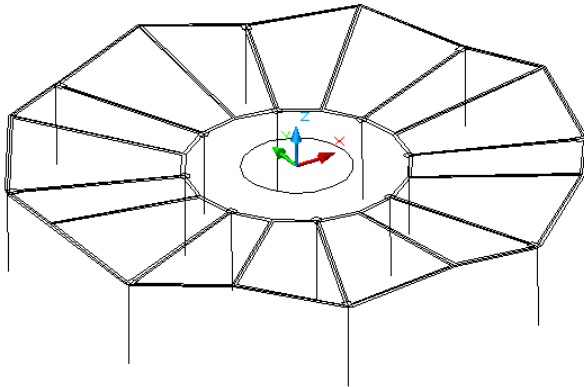

7.1 AutoCAD PREPARATION

First we should make a three-dimensional drawing of the structure. After that three-dimensional surfaces have to be created. For drawing the surfaces several AutoCAD commands may be used: *Edge Surface* or *3D Mesh*. If you create the finite element mesh by macros, mesh generation may be exuded. In order to create finite element mesh for the annular slab, two structural lines should be drawn.

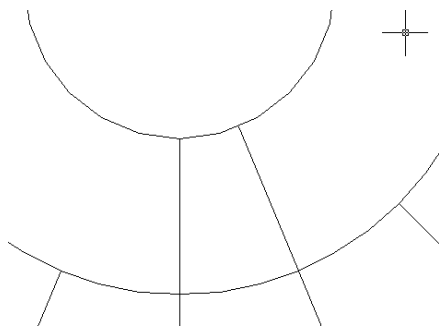

To enable better visual control, three layers should be created: *Axis* - for structural lines, *Construction* - for structure contours and *Meshes* - for wire models of 3D surfaces of the structure. 3D surfaces can be created on all areas of the structure or on one characteristic area and copied in circle raster mesh by using *Array* command. In this example, the mentioned styles for creating the meshes above are not preferred but techniques which depend on the users style.

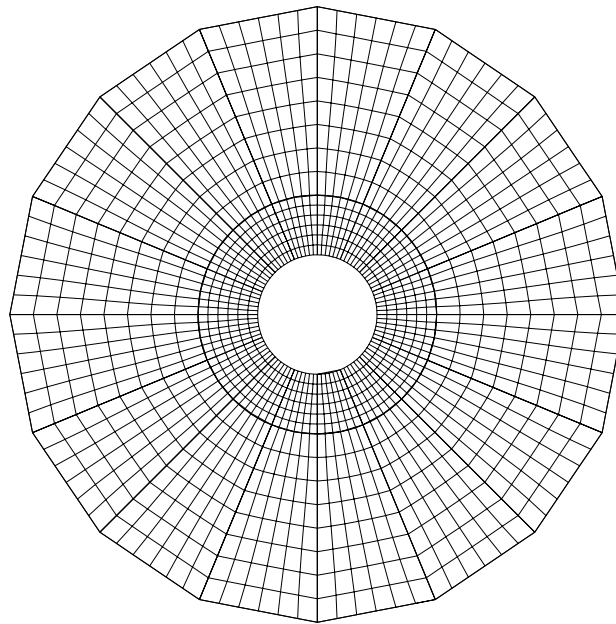

To gain better visual control of the drawing it is desirable to view it from three view ports.

Command: vports

Enter an option [Save/Restore/Delete/Join/Single/?/2/3/4] <3>: **3**

Enter a configuration option [Horizontal/Vertical/Above/Below/Left/Right]

<Right>: **L**

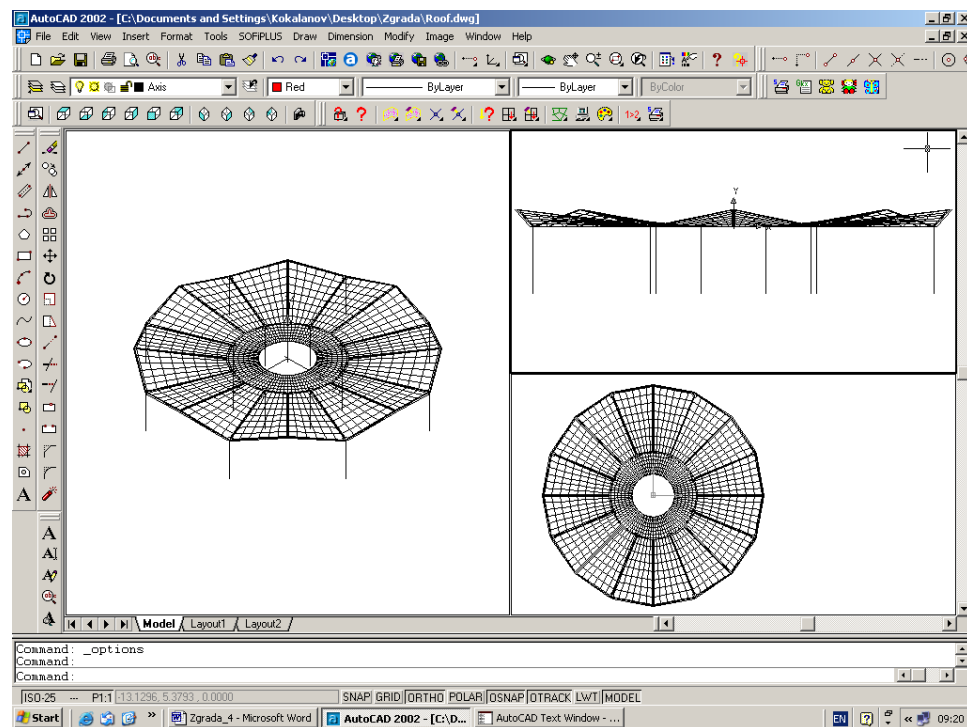

7.2 STRUCTURAL SYSTEM

Structural model of this example is *Space* model. Analysis will be proceeded under EuroCode (EC 2) standards. Structural system is set by:



ICON: Structural system
 MENU: SOFiPLUS → Structural system...
 Command: SOF_GSYSMOD

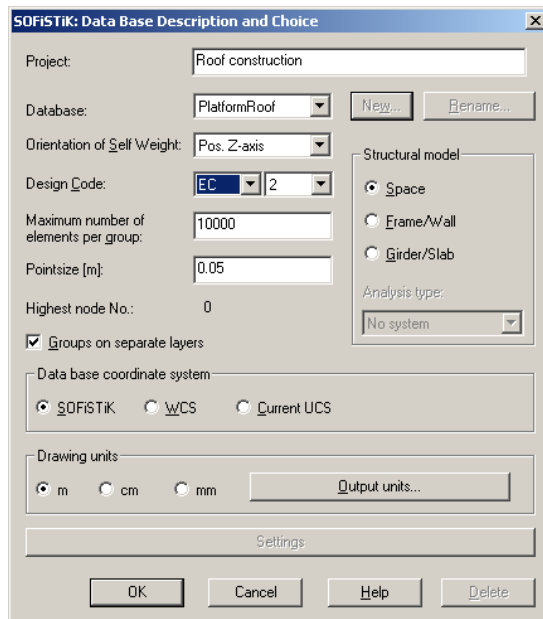

Input parameters for the structural system and database are:

Project	Roof construction
Database	PlatformRoof
Orientation of Self Weight:	Pos. Z axis
Maximum number of element per group	10000
Point size	0.05
Structural mode	Space
Database coordinate system	SOFISTIK
Drawing units	m

7.3 MATERIAL

Slab material is concrete 35.



ICON: Material
 MENU: SOFiPLUS →Defined model→Material
 Command: SOF_GSYMATE

Default materials are used:

Standard Concrete	S35 (EC 2)
Standard Reinforcing Steel	S500 (EC 2)

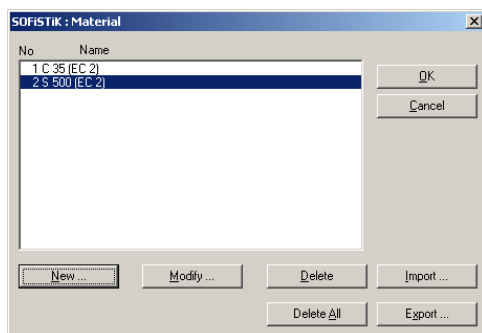

7.4 CROSS SECTIONS

Three types of cross sections are used in this example: rectangular (b/h=30/30 cm), square (b/h=40/40 cm) and circular (d=40 cm).



ICON: Cross Section
 MENU: SOFiPLUS →Defined model→Cross Section
 Command: SOF_GQUER

In the dialogue box click on *New* button.

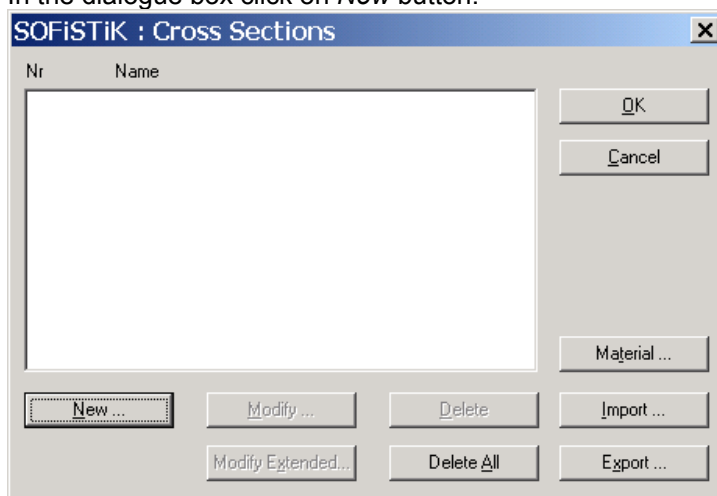

Select *Rectangle* cross section from the list.

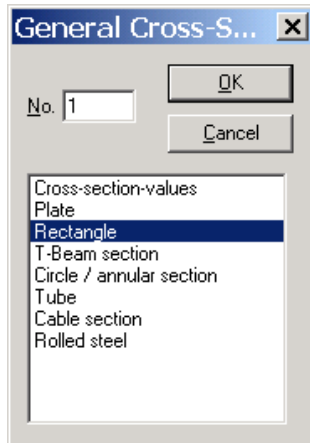

and enter cross section data for edge beams.

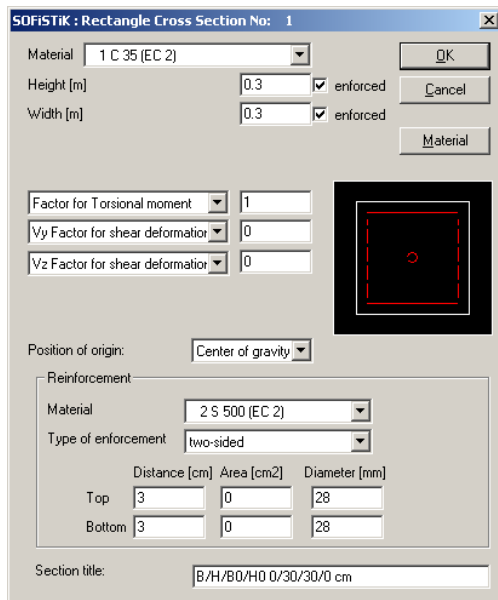

Continue entering cross section data as explained before.

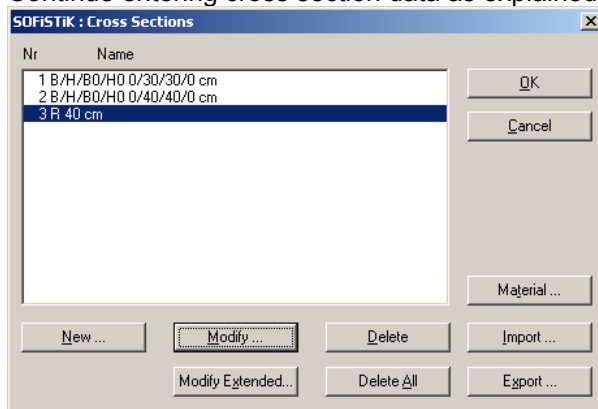

7.5 FINITE ELEMENT MESH

Finite element mesh can be created by objects or by macros. In this example, it is much simpler to generate finite element mesh by objects. Mesh is already generated by AutoCAD commands and should be selected and converted in finite element mesh. The best way to do this is to use second drawing projection. Select the upper part of the structure using *Select Window*.

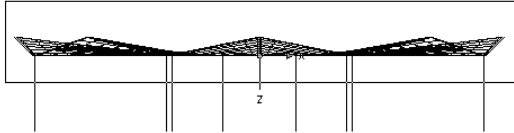

It is recommended to turn off all layers except layer with surface meshes.



ICON: Generate with Objects
 MENU: SOFiPLUS →Generate→With Objects
 Command: SOF_GNETGEN

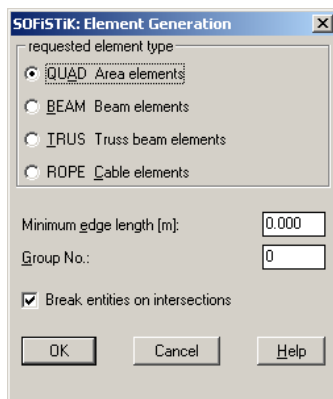

After selecting the roof structure, on the following question:

First Element number<1>: 1

enter number of the first element in the selected group (1).

7.6 FINITE ELEMENT MODIFICATIONS

Slab elements created by objects are formed with thickness equal to assumed (20 cm). In the example, thickness of the shell elements is 8 cm and circle annular slab has thickness 16 cm. Modification of the finite element thickness is necessary. Change is done by command *Modify Area Element* or *Modify Area Element Variable*. As previously explained, first commands is used whenever modification is permanent along whole selected slab area while second command is used when slab has variable characteristics (variable thickness, etc). To change the thickness in this example first command is used.



ICON: Modify Area Element
 MENU: SOFiPLUS→Modify Finite Element→Area Element
 Command: SOF_GQUADMOD

Select all element which will be changed. In this example select all shell elements. After selection, in the following dialogue box

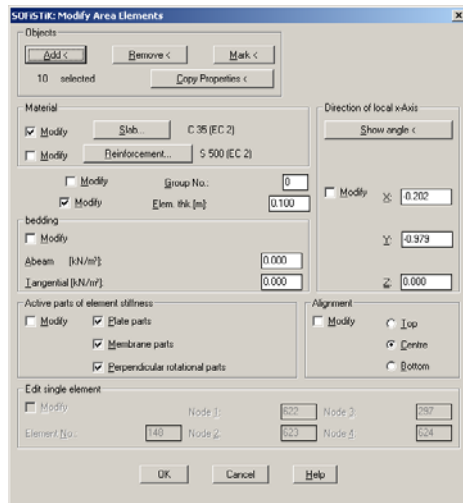

enter slab thickness 0.10 m in the edit text box *Dim*. Change the annular slab thickness as performed before. (d=0.16 m)



ICON: Info/Edit
 MENU: SOFiPLUS→Info/Edit...
 Command: SOF_GINFO

If you click with the mouse inside any element area, information about element are presented as on the picture.

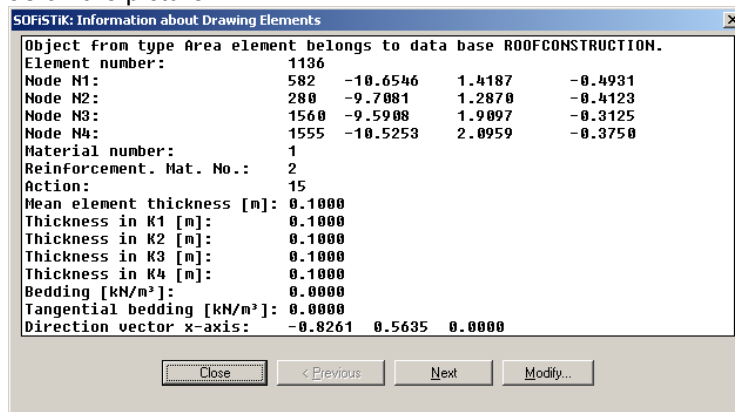

7.7 EDGE BEAMS

Whenever structural model is consisted of combination of beam and area/shell elements, attention should be paid on generation schedule. First, area/shell element mesh should be formed and then beam element mesh. At this sequence SOFiPLUS easily recognizes nodes on the mesh which lie on beam axes. This parts are divided on segments, so beams and area element have same nodes.

Activate *Beam* command.



ICON: Beam
 MENU: SOFiPLUS→Create Finite Element→Beam
 Command: SOF_GSTAB

Command:
 Start node (end+mid+nod+int): (First beam node)
 End node (end+mid+nod+int): (End beam node)
 Rotation of y-axis <0> or [Xx/Yy/Zz/Negx/nEgy/neGz]: **Return**

Connect marked intermediate node? [<Yes>/No]: **Y**
 (Program recognizes inter-nodes which lie between first and end node, and if you answer with Y on the question, nodes are temporary marked. With this action easier control of the beam element generation is enabled).

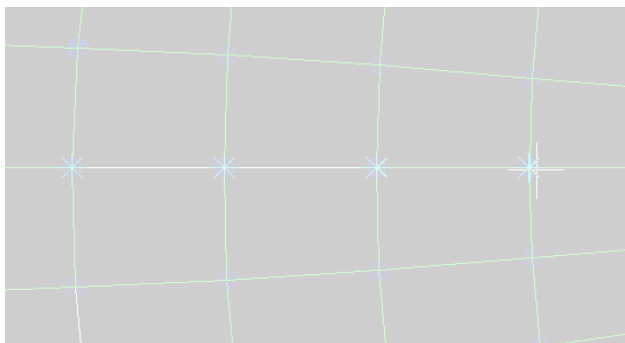

First Beam No.<1>: **1**
 Section number<1>: **1**

Start node (end+mid+nod+int): (Continue with next beams)

All beam elements are generated as stated before.

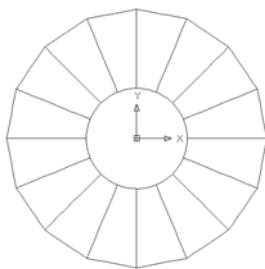

7.8 COLUMNS

In this example two types of columns are used: circle and square. For circle columns position of the local Y-axis is not important, while at square columns you should be careful because they are in rotating position so Y-axis has different orientation of the columns. Firstly circle columns are generated. Columns are beam elements formed with *Beam* command. Generation method is previously explained and will not be repeated here.

Command:
 Start node (end+mid+nod+int): (Start column node)
 End node (end+mid+nod+int): (End column node)
 Rotation of y-axis <0> or [Xx/Yy/Zz/Negx/nEgy/neGz]: **Return**
 marked intermediate node? [<Yes>/No]: **Y**

First Beam No.<1>: **256**
 Section number<1>: **3**

Start node (end+mid+nod+int): (continue with next circle column)

Rectangular columns are formed by same method. Difference is in section number (2) so, now for every column, orientation of the Y-axis should be entered.

Proposed procedure for creating finite element mesh is not general. If user is familiar with AutoCAD, he may find out more adequate work styles. For example, observed structure is formed by 8 equal segments. Instead creating finite element mesh for whole structure, mesh can be formed on one segment.

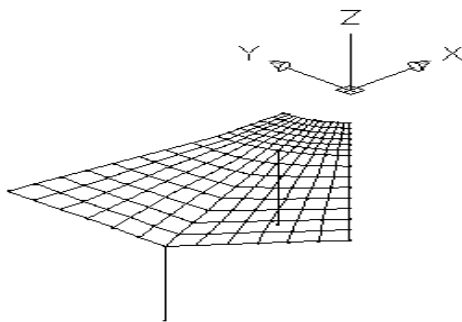

By using AutoCAD command *Copy Array (polar)*, other segments are created. This way is simpler because at copying process, option: *rotate object as copied* is involved and adjustment of the local Y-axis of columns is automatically executed.

This approach requires special attention. Finite element meshes have to concur ideally. Having in mind that AutoCAD disposes of great number of tools for precise positioning this correspondence is not a problem. When SOFiPLUS copies segments, it does not automatically enters new node points. Therefore this type of generated mesh is liable to regular controls.



ICON: Import
 MENU: SOFiPLUS→Analysis Data Base (CDB)→Import (.cdb→.dwg)
 Command: SOF_GENFIN

In the dialogue box, select the option: *Check run (no output)*. As stated before in the text, this Command eliminates errors according as node duplication, deletion of nodes connected to elements and etc.

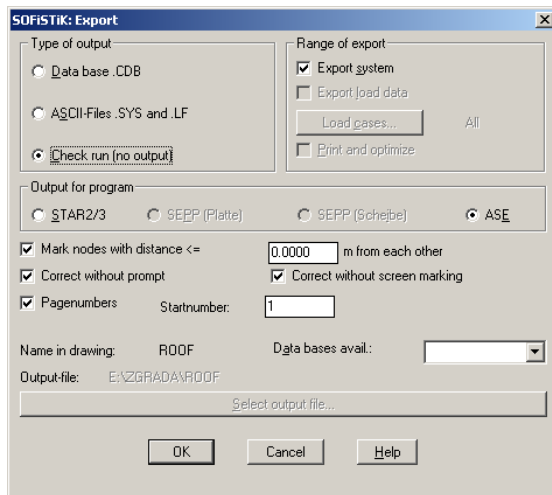

7.9 LOADING

At finite element mesh generation process by objects and macros, load cases are not automatically created. Firstly define load cases using *Loadcase Manager* and afterward apply the loads which act on the slab.



ICON: Loadcase Manager
 MENU: SOFiPLUS → Loadcase Manager
 Command: SOF_GLFMOD

Two load cases will be analyzed.

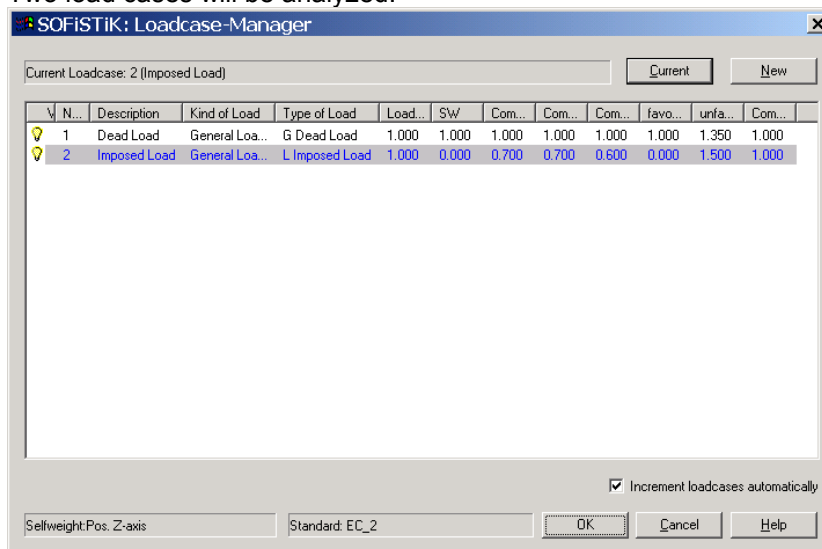

Enter SW 1.00 for the first load case. It denotes that self weight of the elements is automatically calculated in this load case and participates 100%. As a result of other dead loads, the whole slab should be loaded with load of 2.00 kN/m². To input this load in the computation, first in *Loadcase Manager* make the first load as current. Select the first load case and click on the *Current* command button.

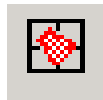

ICON: Free Area
 MENU: SOFiPLUS→Create Loads→Free Area
 Command: SOF_GBLAS

Enter load attributes in the following dialogue box.

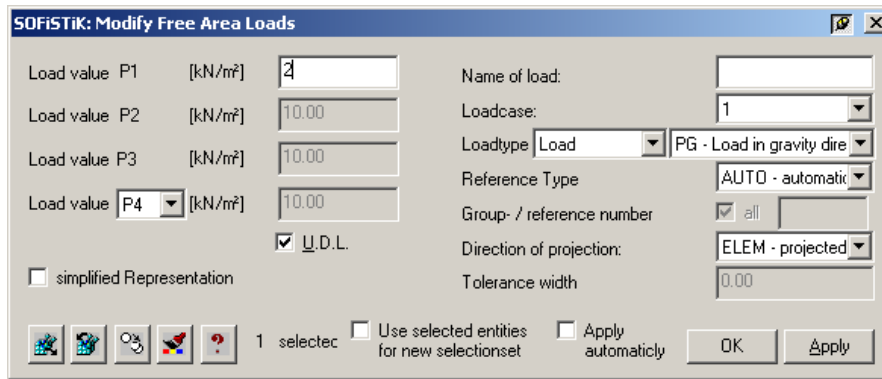

U.D.L. (Uniform Distributed Load) check box is marked which specifies that load is uniformly distributed. In the edit box enter load value 2.00 kN/m². For *Loadtype* pick *Load in gravity direction* to define load direction. Pick four nodes on the screen which form square area and cover the part of the slab area to transfer loads. This area may come out of the slab contours, so the program automatically calculates certain loads on area elements.

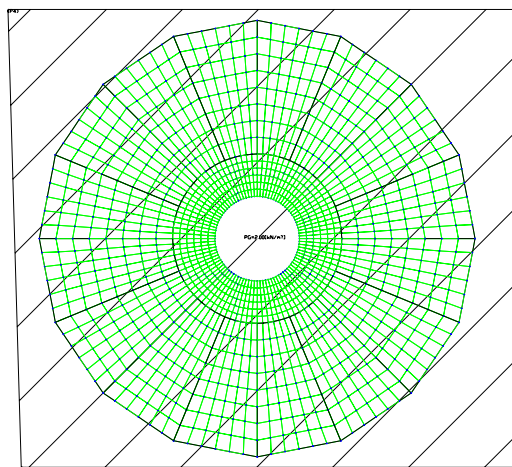

To have better visual control of the process, loading area is hatched. Loading area of the slab is drawn on the layer: X__B001__ROOFCONSTRUCTION. To obtain greater visual control over the loading areas it is desirable to close this layer, before entering loads for the second load case.

In order to illustrate other possibility for entering loads, small modification in the finite element properties from annular slab is created. All its finite elements are placed in group 1.



ICON: Modify Area Element
 MENU: SOFiPLUS→Modify Finite Element→Area Element
 Command: SOF_GQUADMOD

Select the elements from the annular slab.

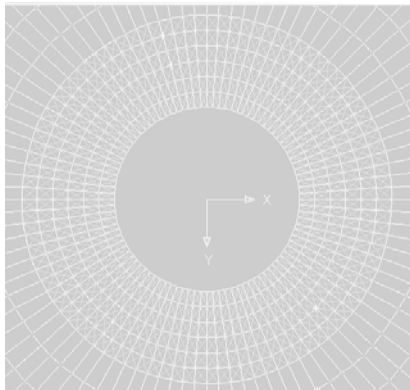

In the edit box *Group No.* enter group 1. Since maximal number of elements in one group is appointed to 10000 (Structural system ...), numbering of the elements starts from 10000. In the second load case two distributed load act on the slab: central part is loaded with 7.00 kN/m² whilst hallway is loaded with 4.00 kN/m². Make the second load case current by using *Loadcase Manager*. Trigger command *Create Loads*→*Free Area* and enter load parameters.

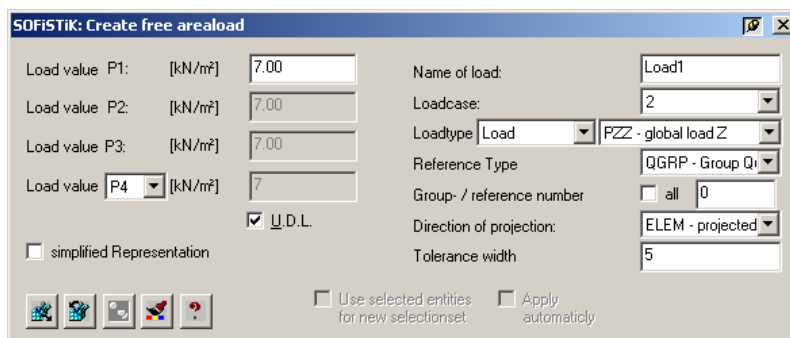

At entering the second load case load distribution is conducted according the group of member elements.

Reference Type QGRP – Group Quadrilateral Element

Click to clear *ALL (Group/reference Type)* check box and enter the group on which load 0 acts.

Direction of projection ELEM – projection

Load acts along element projection perpendicular to load direction (PZZ – global load Z).

Tolerance width 5

This reference defines depth for the load. All QUAD elements on distance +/- 5 m from the loading area will be loaded with prescribed load.

First load for shell elements is entered with value of 7.00 kN/m².

Command:

pick 1 cornerpoint (end+mid+nod+int) or [Enter polygon]: e

(Loading area is polygon)

pick 1 cornerpoint (end+mid+nod+int): (First polygon node)

pick 2 cornerpoint (end+mid+nod+int) or [Undo]: (Second)

pick 3 cornerpoint (end+mid+nod+int) or [Undo]: (Third)

pick 4 cornerpoint (end+mid+nod+int) or [Undo]: (Fourth)

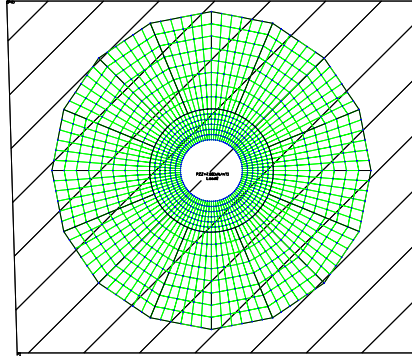

Repeat this process for the central annular slab. Its area is loaded with uniformly distributed load of 4.00 kN/m^2 and its elements are in group 1.

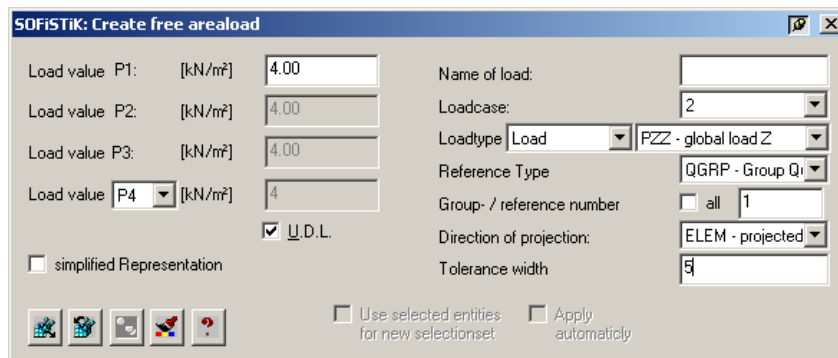

Loading area may be same as in the previous case. Analysis database exportation and analysis process are same as in the other examples and are not presented here.

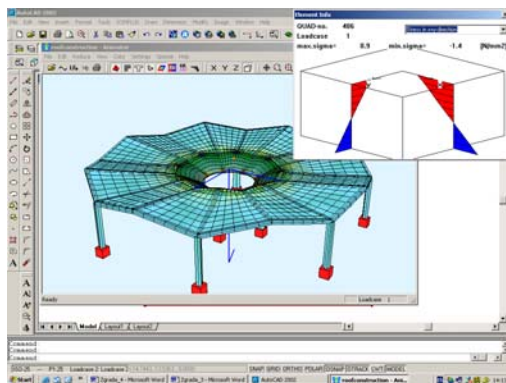

8. Space Analysis of the building

In previous chapters specific floors of a building were under observation. Using 2D analysis static values in area and beam elements of the entresols were calculated. In continuance, the same structure is reviewed, as overall or space structure. Proposed methodology is only one of the possible solutions. Purpose of this example is to present AutoCAD and SOFiPLUS capabilities, not to give critical mark of the structural solution namely mathematical model. First make a drawing of the building with entered all characteristic plans of the building. For easier manipulation, separate plans are placed on different layers.

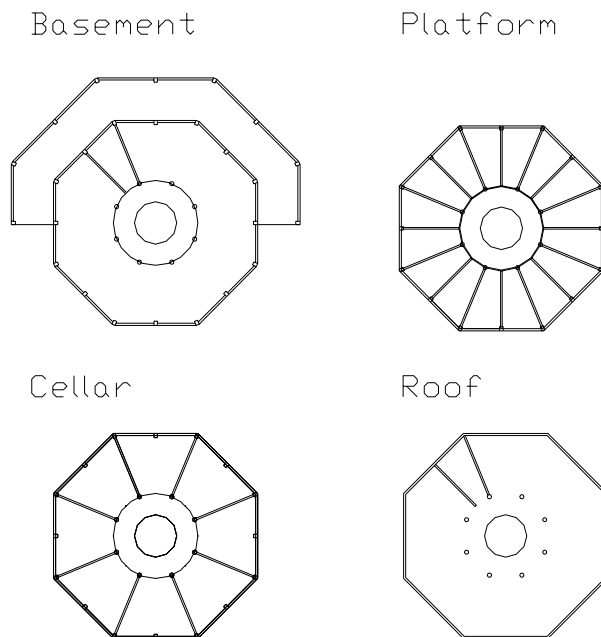

Concept of the analysis is as follows:

- For every characteristic platform make mathematical model (finite element mesh/loads);
- Put all platforms in their positions in the structure (Move/Copy);
- Connect platforms by columns and walls;
- Enter supports;
- Enter additional loads which are not previously entered in the separate platform analyses;
- Check the structure;
- Analysis;
- Presentation of the results.

8.1 STRUCTURAL SYSTEM

Structural system is *Space*. Analysis is performed following DIN (EC 2) standards. Structural system is entered by:



ICON: Structural system
 MENU: SOFIPLUS → Structural system...
 Command: SOF_GSYSMOD

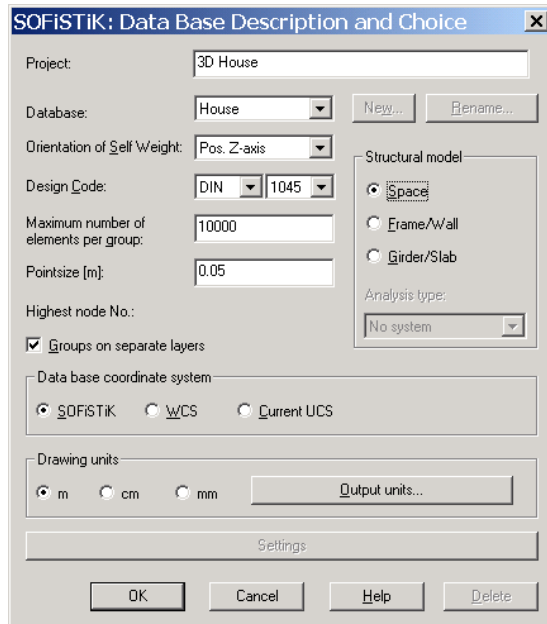

In the *Data Base Description and Choice* dialogue box enter the following database parameters:

Project	3D House
Database	House
Design Code	DIN 1045
Orientation of Self Weight:	Pos. Z axis
Maximum number of element per group	10000
Point size	0.05
Structural mode	Space
Database coordinate system	SOFiSTiK
Drawing units	m

8.2 MATERIAL

Slab material is concrete 35.



ICON: Material
 MENU: SOFiPLUS →Defined model→Material
 Command: SOF_GSYMATE

Enter materials for the inspected structure in the dialogue box.

Standard Concrete	C 35
Standard reinforcing Steel	BST 500

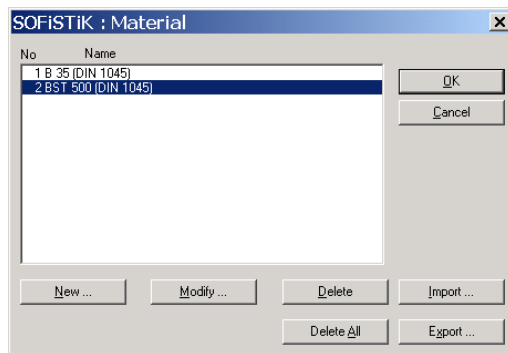

8.3 STRUCTURAL LINES

As background for defining mathematical model architectural drawings are used. This drawing is utilized to train structural lines. For outward walls structural line passes on 1/3 of the wall thickness.



ICON: 1/3 Line
 MENU: SOFiPLUS →Defined model→Auxiliary Line→1/3 Line
 Command: SOF_DRITTEL_LINIE

Firstly click on the inner wall line and then on the outward line. SOFiPLUS draws structural line on 1/3 of the inner wall edge.

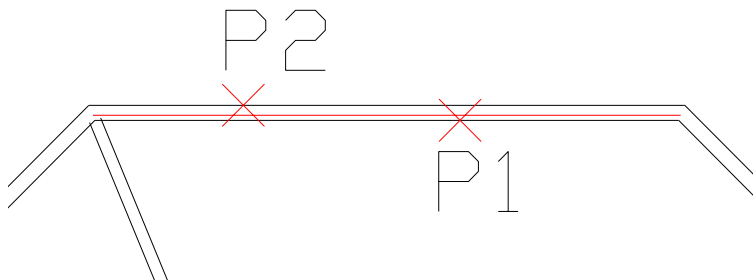

Inner walls are presented with structural lines which pass through center of the wall.



ICON: Center Line
 MENU: SOFiPLUS →Defined model→Auxiliary Line→ Center Line
 Command: SOF_MITTEL_LINIE

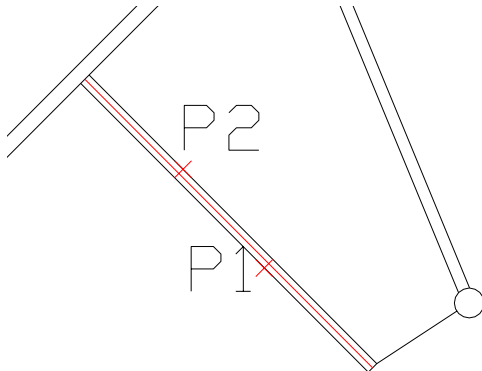

Structural lines are placed on layer: X_AUFL

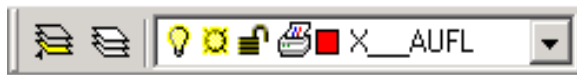

Beside these lines, several other structural lines are drawn. By using simple AutoCAD command *Line*, draw lines over the contours of the area segments. These lines should be placed on layer: X_AUFL. If these lines are not on the stated layer, you must change *Layer* attribute on all lines.

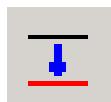

ICON: Copy to structural Layer
 MENU: SOFiPLUS→Defined model→Auxiliary Line→S Copy to structural Layer
 Command: SOF_DRITTEL-LINIE

After selecting this command, click on the auxiliary lines. Lines are now transported on layer: X_AUFL and they become structural lines.

8.4 STRUCTURAL AREAS

Structural areas are parts of the slab limited with structural lines. At space systems, lines should be coplanar. Before defining the areas it is desirable to close all layers except layer with the structural lines. After that make control over the components of the structural lines so as to eliminate errors (usually contours are not ideally closed) or to select creating areas by selecting contour lines which do not require closed contours.



ICON: Structure area
 MENU: SOFiPLUS→Defined model→Structure area
 Command: SOF_PM_AREA

Execution of the command is combined: by selecting data on the command line:

Select option <Pick point in area>[PICK Point in area /SELECT Boundary/SELECT Plane/PICK Structural edge]:

and by entering slab attributes in edit boxes in the *structural area* dialogue box.

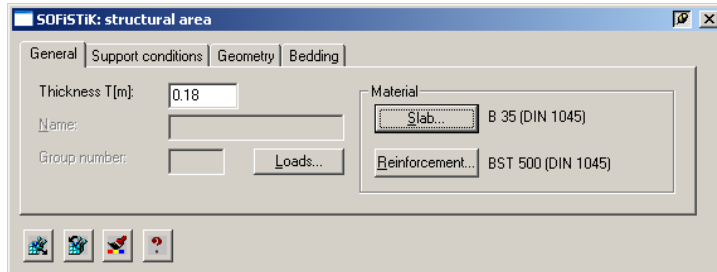

Predefined slab thickness is 18 cm. If this thickness is not adequate it should be changed. Current materials are shown in the window. They can be changed using buttons *Slab* (for concrete) and *Reinforcement*.

Loads... button starts the process of defining loads for the area which is generated. By first start of *Loads...* *Loadcase Manager* dialogue box is called up because there are no previously defined load cases. In this dialogue box enter all load cases which will be used in the slab analysis process, and place the current load case which will be first to define the loads. In this example it is 1 Loadcase Dead Load.

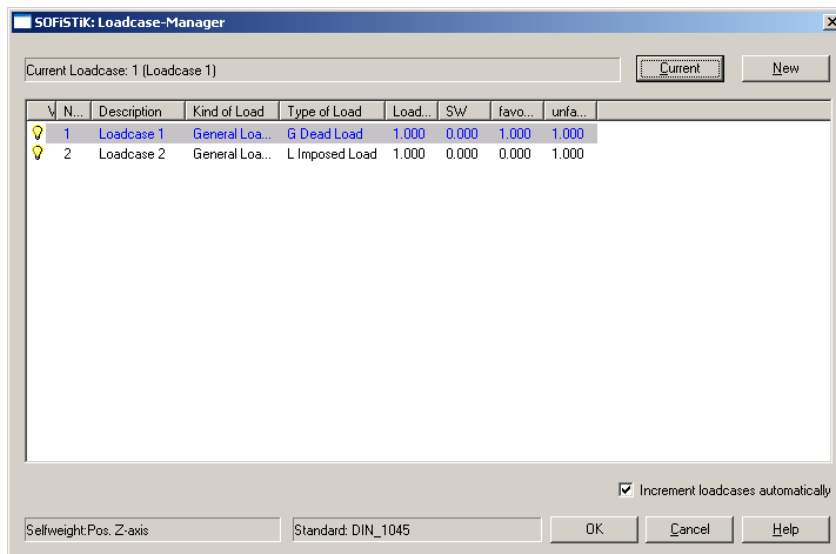

In *Loads and Areas* dialogue box enter value for the *Dead load* 1.5 kN/m² and *Imposed load* 3.5 kN/m².

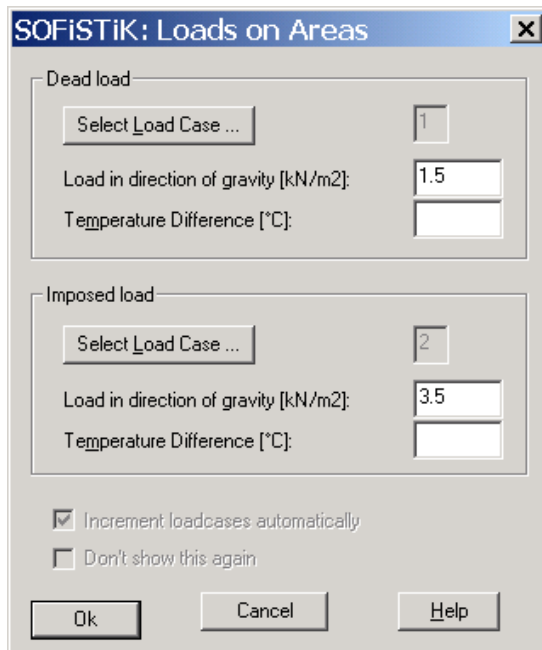

Since loads are entered, click inside closed contour. SOFiPLUS analyzes contour and if everything is correctly specified it marks the contour and displays labels for area and loads. Structural areas may be generated by clicking point which lies inside area contour or by clicking on the boundary lines (SELECT Boundary) namely structural edges (PICK Structural edge).

Select option <Pick point in area>[PICK Point in area /SELECT Boundary/SELECT Plane/PICK Structural edge]:

If first option is used (Pick point in area), contour which defines structural area has to be ideally closed and has to lie in current XY plane. For example, if structural area of one of the vertical walls has to be defined, first a change in coordinate system has to be made, so the wall should lie in the new XY plane.

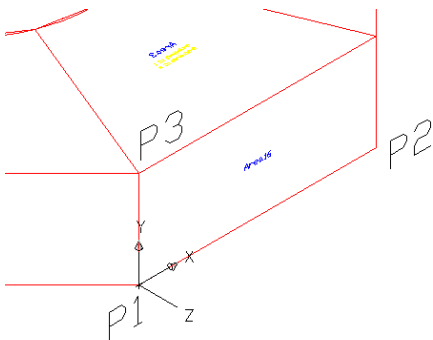

Select option <pick Structural edge>[PICK Point in area/SELECT Boundary/SELECT Plane/PICK Structural edge]: **select-p** (defines new drawing plane-xy)
_3point

Specify new origin point <0,0,0>: (click on point P1)

Specify point on positive portion of X-axis <-3.8588,-11.9044,-4.0000>: (click on point P2)

Specify point on positive-Y portion of the UCS XY plane

<-4.8588,-10.9044,-4.0000>: (click on point P3)

This process continues with entering point which lies inside closed wall contour. If the procedure is correctly performed, program itself labels the area displaying the number and load values.

At complex areas second mode for defining structural areas is simpler to use, by selecting the structural edges (PICK Structural edge). Before this option takes place, auxiliary lines which will be used for defining area contours have to be converted in structural edges.



ICON: Structure edge
 MENU: SOFiPLUS→Defined model→Structure edge
 Command: SOF_PM_EDGE

Start point (end+cen+nod+int) or [Select entity]:
 (select entities to convert into structural edges)

You should have in mind that selection direction determines direction of local Y-axis. User should pay attention on the text shown after creation of the structural area. If text is normal, local Z-axis is directional to user. If text is inversed, local Z-axis is in the reversed direction. It is eligible to make visualization by showing the directions of the local element axes.

8.5 OPENINGS

Definition of the openings at space systems differs from the described definition in line systems.



ICON: Opening
 MENU: SOFiPLUS→Defined model→ Opening
 Command: SOF_PM_HOLE

At space systems, firstly area in which opening lies is set and hence structural lines which define the opening are clicked.

Command:
 Define opening
 structural area: (click on structural area)
 pick structural line (end+cen+int+nea):
 (click on the first structural line)
 pick structural line (end+cen+int+nea):
 (click on the second structural line)

As far as area is correctly defined, program itself marks the area with the text *Hole*.

8.6 BEAMS/COLUMNS

In this example, easiest way to enter beams and columns is by modification of structural edges.



ICON: Modify Structural Edges
 MENU: SOFiPLUS→Modify model→Structural Edges
 Command: SOF_PM_EDGE_M

Select all edges to place rectangular beams. In the dialogue box click on *Beam* tab.

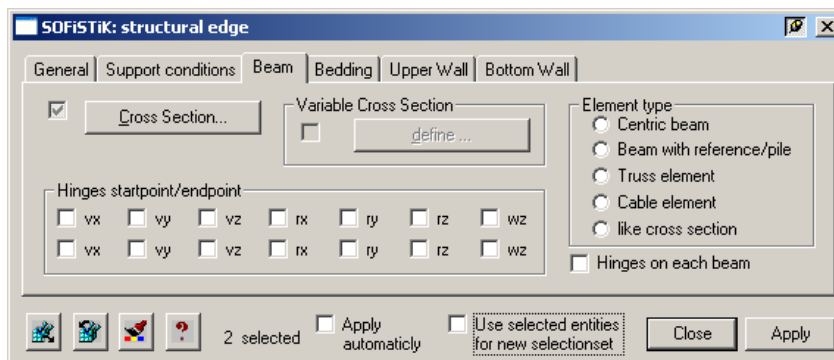

With button *Cross Section*, cross sections of beam elements is created, i.e. cross section of the respective beam. In this example two cross sections are defined: rectangular 40/50 cm and circular d=40 cm,

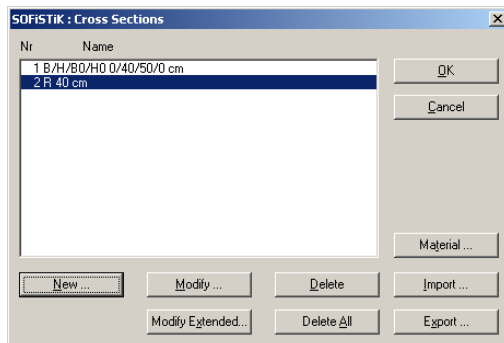

and cross section 1 of beam elements is selected. Similarly columns which lie on area boundaries are created. These columns have section no. 2. The rest columns are created with command:



ICON: Beam
 MENU: SOFiPLUS→Create Finite Elements→Beam
 Command: SOF_GSTAB

Command:
 Start node (end+mid+cen+nod+qua+int+per+nea):
 (Enter first node of the column)
 End node (end+mid+cen+nod+qua+int+per+nea):

(Enter second node of the column)
 Rotation of y-axis <0> or [Xx/Yy/Zz/Negx/nEgy/neGz]:
 (Enter rotational angle of column local y-axes)
 First Beam No.<337>: **Return**
 Section number<1>: (Enter section number)
 Start node (end+mid+cen+nod+qua+int+per+nea): **Return**

To simplify this process, only one column may be created and the rest may be copied with AutoCAD commands Copy or Array.

NOTICE: When elements are copied (Copy or Array), the program does not enter new nodes automatically. Therefore control of the system is necessary.



ICON: Import
 MENU: SOFIPLUS→Analysis Data Base (CDB)→Import (.cdb→.dwg)
 Command: SOF_GENFIN

In the following dialogue box click to check: *Check run (no output)*. As stated before this command eliminates errors like node duplication, deletion of nodes which are connected to elements and etc.

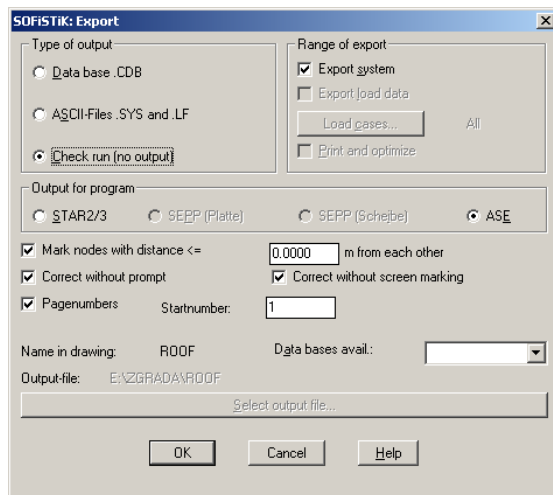

8.7 BOUNDARY CONDITIONS

As difference from plane structures where by definition area edges are formed as freely supported (PZZ), in space structures by definition no limitations of structure are introduced. Walls are plane structures which have constrained displacements in the supports along the length and height of the wall (local X and Z coordinate).

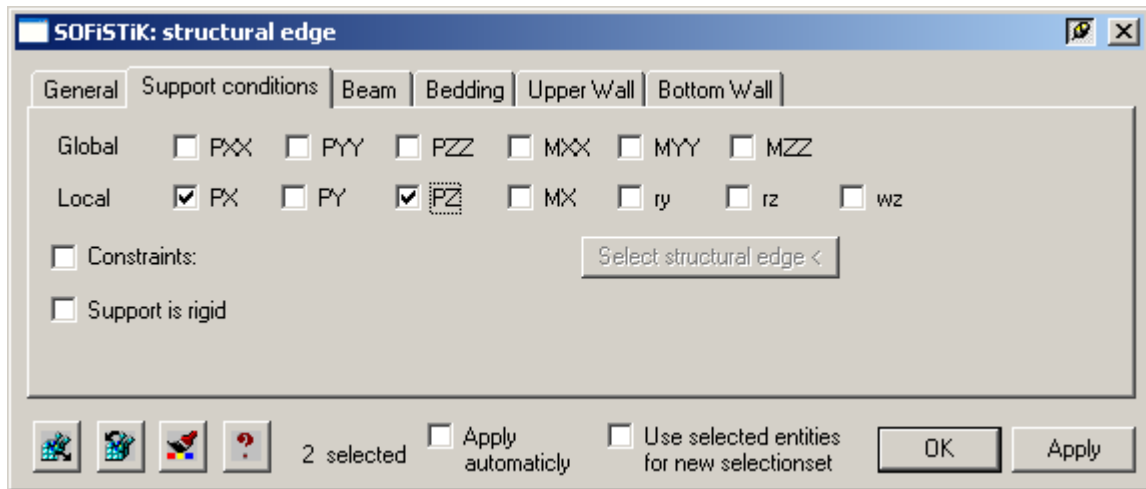

Also, displacements in the points where columns are supported should be constrained. Since these nodes are spatial, displacements and rotations in all directions of the supports should be constrained.



ICON: Modify Structure Point

MENU: SOFiPLUS→Defined model→Modify Column/Structure Point

Command: SOF_PM_POINT_M

Select all points of column supports and mark all boxes of prescribed deformations.

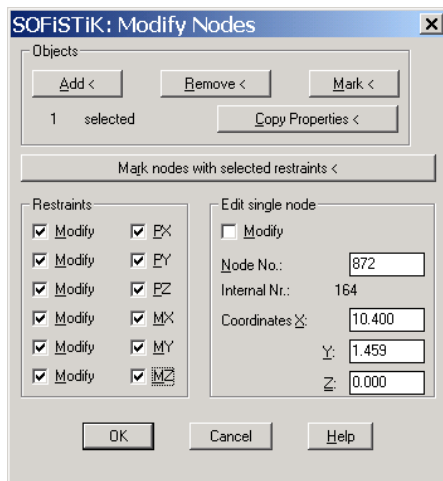

8.8 FINITE ELEMENT MESH (FEM)

The procedure conducted in the previous steps is predefined for automatic finite element mesh generation.



ICON: Mesh Generation

MENU: SOFiPLUS→Generate→Automatic mash generation

Command: SOF_G_MASHGEN

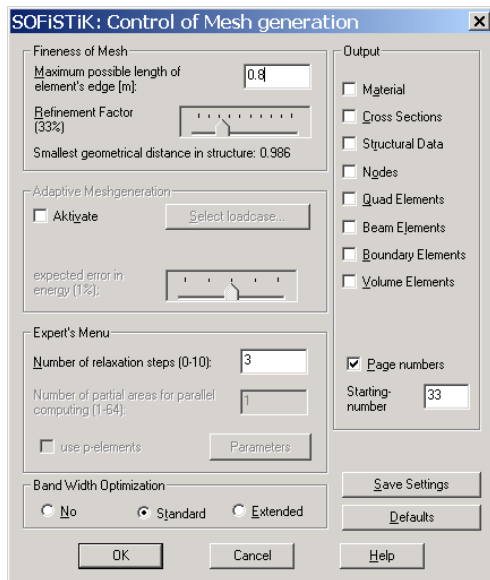

Accept maximum length of element's edge 0.8 m, and leave the remaining parameters as selected by default.

8.9 DATABASE IMPORT

When generation process is finished, finite element mesh is invisible for the user. To display it on the screen analysis database should be imported.



ICON: Import

MENU: SOFiPLUS→Analysis Data Base (CDB)→Import (.cdb→.dwg)

Command: SOF_GENFIN

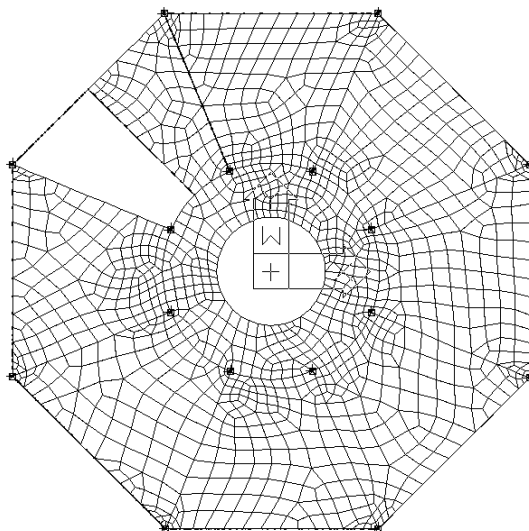

8.10 STRUCTURE CONTROL

Since mesh is generated, it is advisable to make visual control over the structure. Program *Animator* enables the best visual control of the structure.

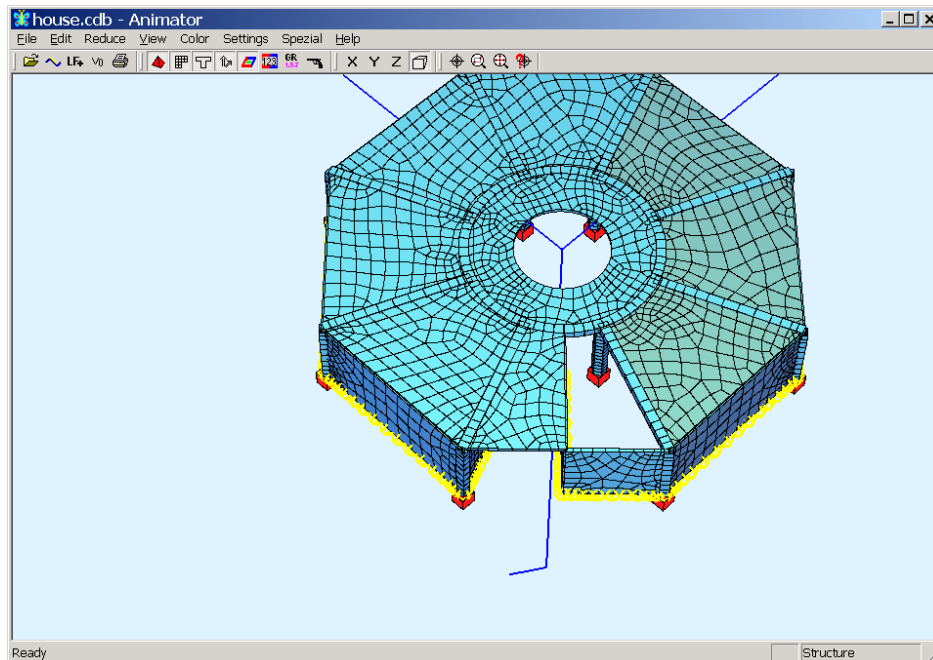

Straightaway user notices that error occurred while modeling the structure. Region over the staircase area is molded with finite elements. This region should be empty and the neighboring area has to be moulded.

Also good practice is to check supports. Usually at complex structures, some supports may be forgotten or wrong moulded.

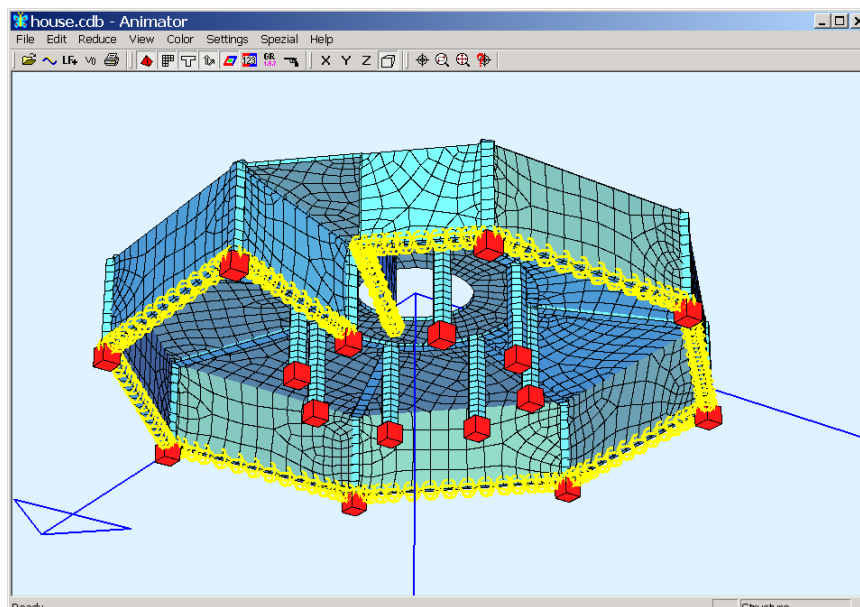

In this case there are no errors in the supports.

8.11 CORRECTION OF THE FINITE ELEMENT MESH

In the inspected example, errors are eliminated by deleting the structural area over the staircase region (use AutoCAD command *Erase*) and designing new area in the neighboring area. After this corrections, finite element mesh and visual controls should be repeated. You should be careful when re-creating the finite element mesh prescribed displacements in points on the columns are not remembered and must be set again.

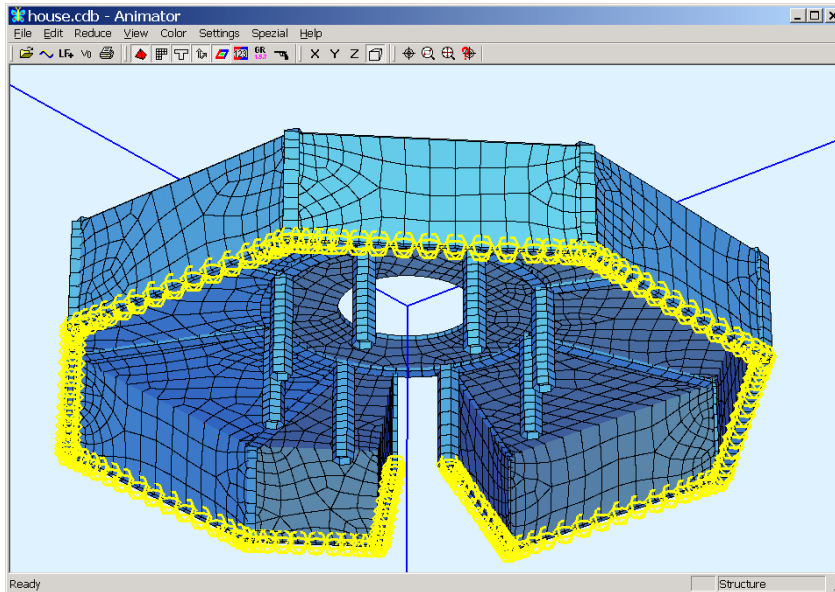

Correct structure is shown below.

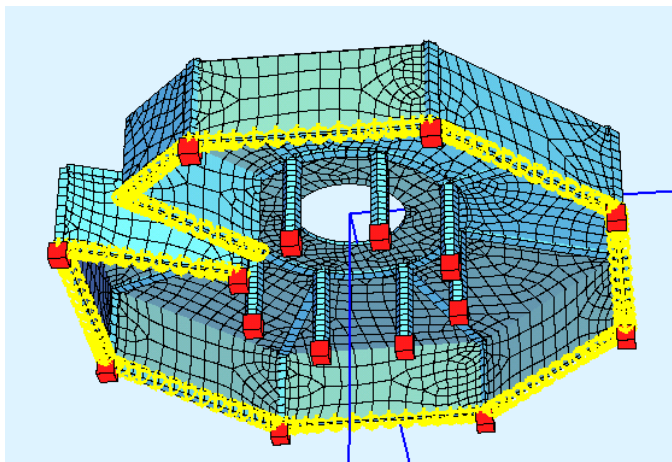

Usually, in the process for generation structural areas, schedule of edge selection is not taken under consideration. As a result, local coordinate systems of area segments may be irregularly oriented. Ordinarily control on the local systems of area elements is made.



ICON: Display Area Elem. Coordinate System
 MENU: SOFIPLUS→Visualize→Area Elem. Coordinate System
 Command: SOF_GQKS

Select the elements to draw coordinate systems. It is enough to select one element from the group, because all elements have same orientation.

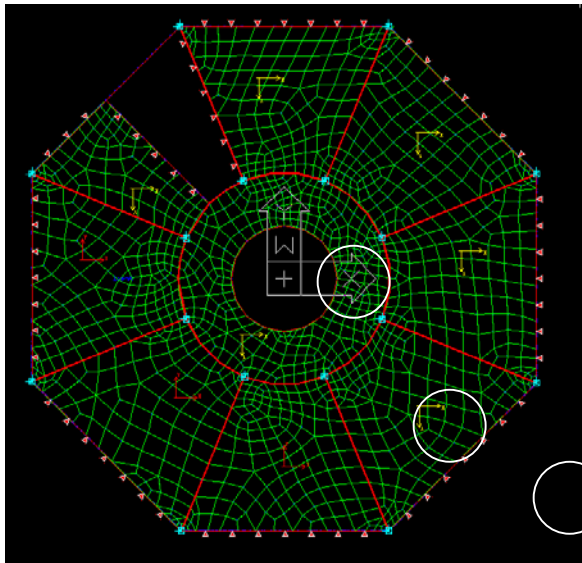

For this example, it is obvious that three areas are oriented in opposite direction to the default (Z-axis should be downwards). For these areas on all elements local coordinate system should be rotated.



ICON: Rotate Area Element

MENU: SOFiPLUS→Modify Finite Element→Rotate Area Element

Command: SOF_GQUADDREH

Select all elements which have to rotate the local coordinate system.

8.12 BASEMENT PLATFORM

First, *Auxiliary Lines* will be converted into *Structural Edges*. All structural edges, except edges along the central opening, will be generated as beams with dimensions of cross section 40/50 cm.



ICON: Structure edge

MENU: SOFiPLUS→Defined model→Structure edge

Command: SOF_PM_EDGE

Command: SOF_PM_EDGE

Start point (end+cen+nod+int) or [Select entity]: **S**

(Select all lines which will be converted as beams)

Select objects: 56 found

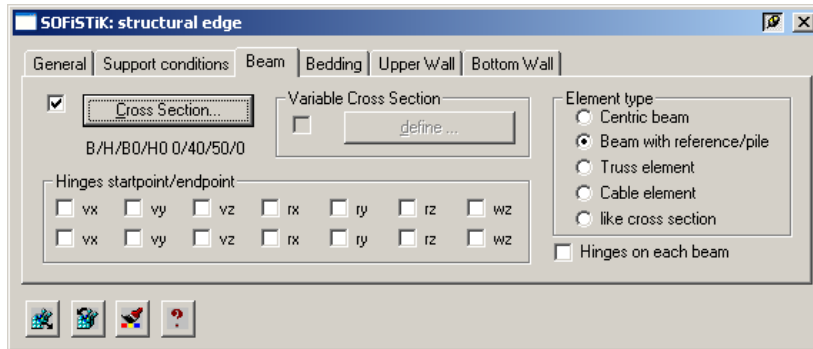

8.13 STRUCTURAL AREAS

Structural areas will be formed with option *Pick Points in Area*.



ICON: Structure area
 MENU: SOFiPLUS→Defined model→Structure area
 Command: SOF_PM_AREA

Select option <Pick point in area>[PICK Point in area /SELECT Boundary/SELECT Plane/PICK Structural edge]: **PICK-P**

To make the creation of the central area much easier, circle opening may be temporary eliminated.

8.14 OPENINGS

During defining the opening in the center of the structure, first select the area in which opening lies, and then the edge which defines the opening.



ICON: Opening
 MENU: SOFiPLUS→Defined model→ Opening
 Command: SOF_PM_HOLE

When circular opening was transformed into structural edge, program divides the opening on four circle arches.

Command:
 Define opening
 structural area: (click on the structural area)
 pick structural line (end+cen+int+nea):
 (click on the first circular arch)
 pick structural line (end+cen+int+nea):
 (click on the second circular arch)

8.15 BEAMS/COLUMNS

Beams will be entered by modifying the structural edges.



ICON: Modify Structural Edges
 MENU: SOFiPLUS→Modify model→Structural Edges
 Command: SOF_SOF_PM_EDGE_M

Select all edges which have to assign rectangular beams along their length. In the dialogue box select *Beam* tab.

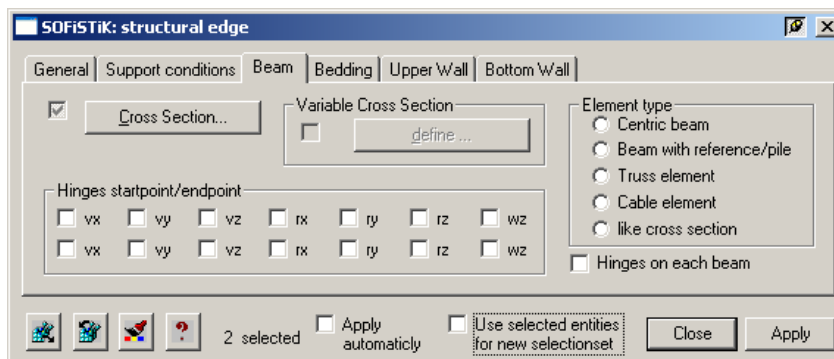

From the list select the appropriate cross section for the beam.

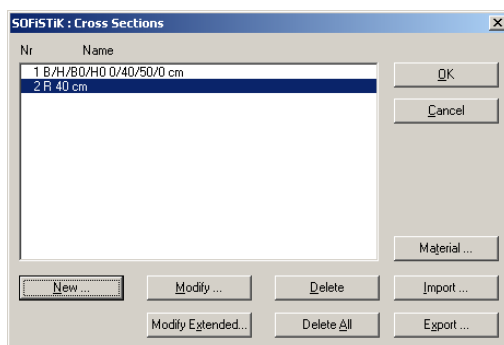

Columns are created with command:



ICON: Beam
 MENU: SOFiPLUS→Create Finite Elements→Beam
 Command: SOF_GSTAB

Command:

Start node (end+mid+cen+nod+qua+int+per+nea):
(Enter first node of the column)

End node (end+mid+cen+nod+qua+int+per+nea):
(Enter second node of the column)

Rotation of y-axis <0> or [Xx/Yy/Zz/Negx/nEgy/neGz]:
(Enter angle of rotation for the local Y-axis of the column)

First Beam No.<337>: **Return**

Section number<1>: (Enter cross section number)

Start node (end+mid+cen+nod+qua+int+per+nea): **Return**

To simplify the process, only one column may be created and the remaining columns may be copied with AutoCAD commands *Copy* or *Array*.

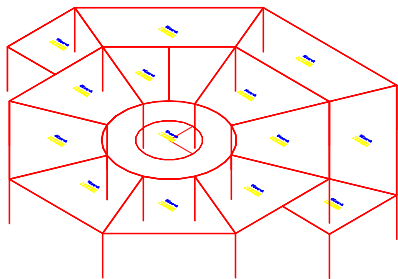

8.16 PERMANENT PLATFORMS

Similarly other characteristic platforms are formed.

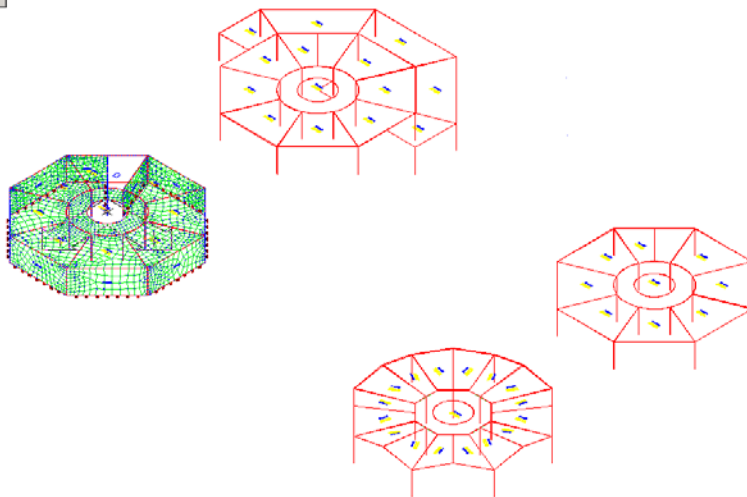

8.17 FINITE ELEMENT MESH (FEM)

Since structural areas will be created, finite element mesh is generated.



ICON: Mesh Generation

MENU: SOFiPLUS→Generate→Automatic mash generation

Command: SOF_G_MASHGEN

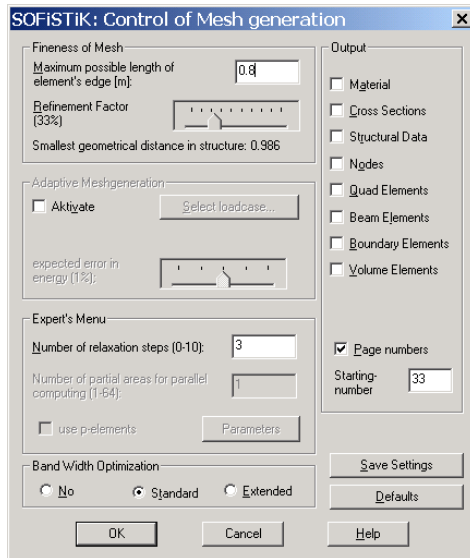

8.18 3D STRUCTURE

In the next steps, each platform is placed on the appropriate location in the structure. Therefore, AutoCAD command *Move* is used. If a platform is repeating in the structure it can be copied with *Copy* command.

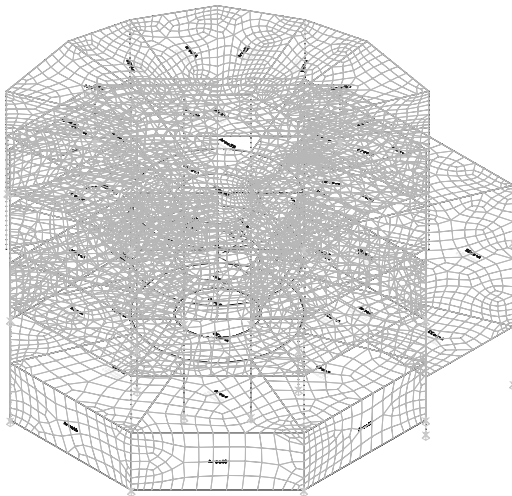

8.19 EXPORTING DATABASE

To save all data related to the drawing in the analysis database, it has to be exported. In complex structures it is advisable to control the database before exporting.

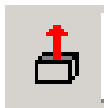

ICON: Export
 MENU: SOFiPLUS→Analyze Data Base (CDB)→Export (.dwg→.cdb)
 Command: SOF_GENFIN

8.20 ANALYSIS OF STRUCTURE

Analysis of the structure is done with *WTEDY* program.



ICON: Edit (Win Ted)
MENU: SOFiPLUS→Analysis ...
Command: SOF_G

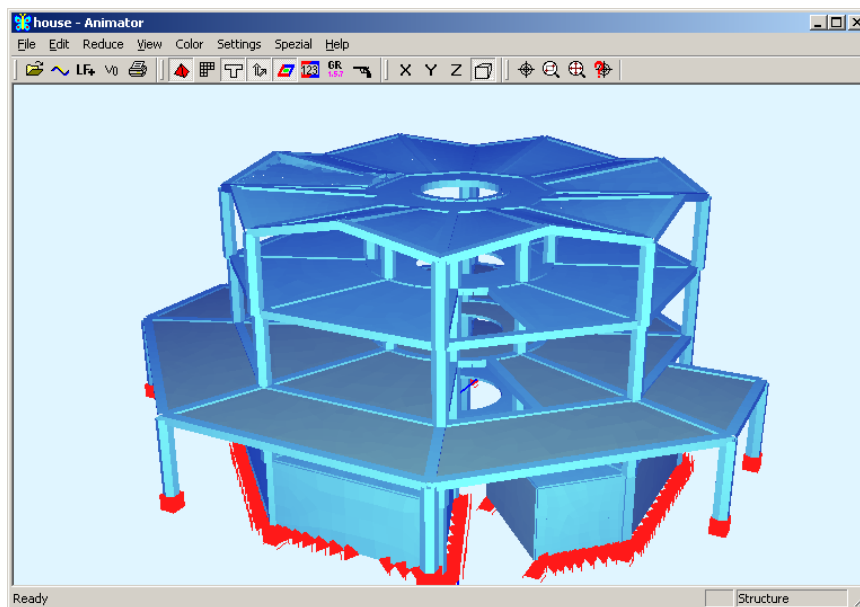

9. SPACE TRUSS - DOME

The space truss creates dome with radius 30 meters. The dome is made from steel tubular profiles. The upper part of the dome has opening for illuminating the interior. The roof is made from light materials that have no structural meaning. The roof is only for covering the area. It receives and transfers loads from self weight, wind, snow and do not participates in force distribution.

9.1 AutoCAD DRAWING PREPARATION

Create layer *Mesh* and use AutoCAD command:

Draw→Surfaces→3D Surfaces→Dish

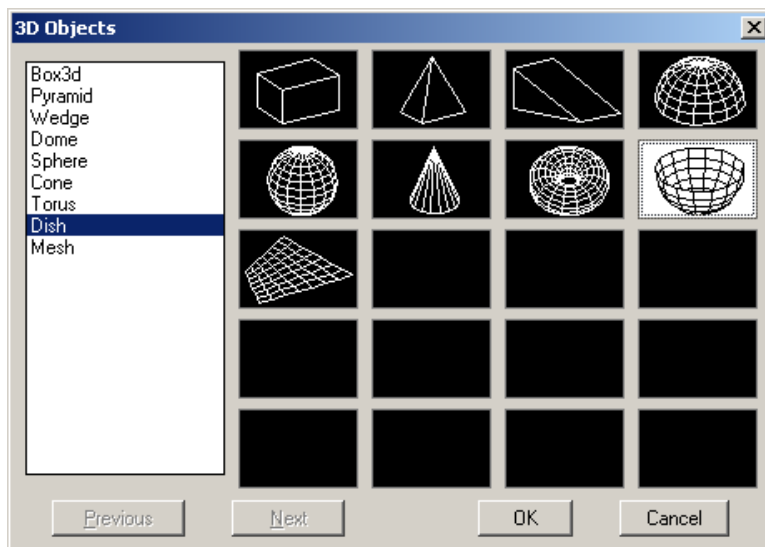

to plot the area of sphere dome.

Command: **ai_dish**

Specify center point of dish: **0,0,0**

Specify radius of dish or [Diameter]: **30**

Enter number of longitudinal segments for surface of dish <16>: **20**

Enter number of latitudinal segments for surface of dish <8>: **10**

Command: **zoom**

Specify corner of window, enter a scale factor (nX or nXP), or

[All/Center/Dynamic/Extents/Previous/Scale/Window]

<real time>: e

The dome is rotated upside down, because you will use SOFiSTiK coordinate system in the analysis, which has opposite direction of Z-axis than AutoCAD.

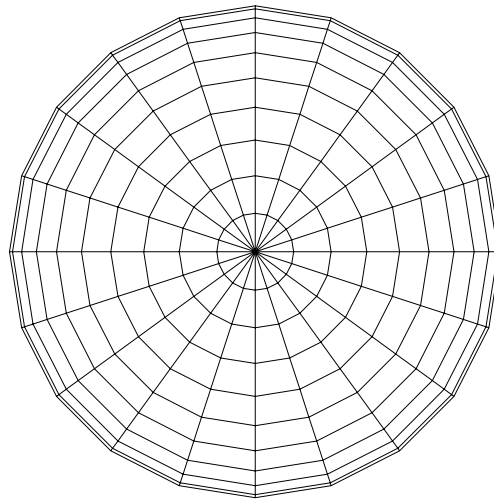

For better description, three view ports are established:

View→Viewports→3 Viewports →L

Command: -vports

Enter an option [Save/Restore/Delete/Join/Single/?/2/3/4] <3>: 3

Enter a configuration option [Horizontal/Vertical/Above/Below/Left/Right]

<Right>: L

Regenerating model.

The first view is axonometric review, the second view is second projection and the third is first structure projection.

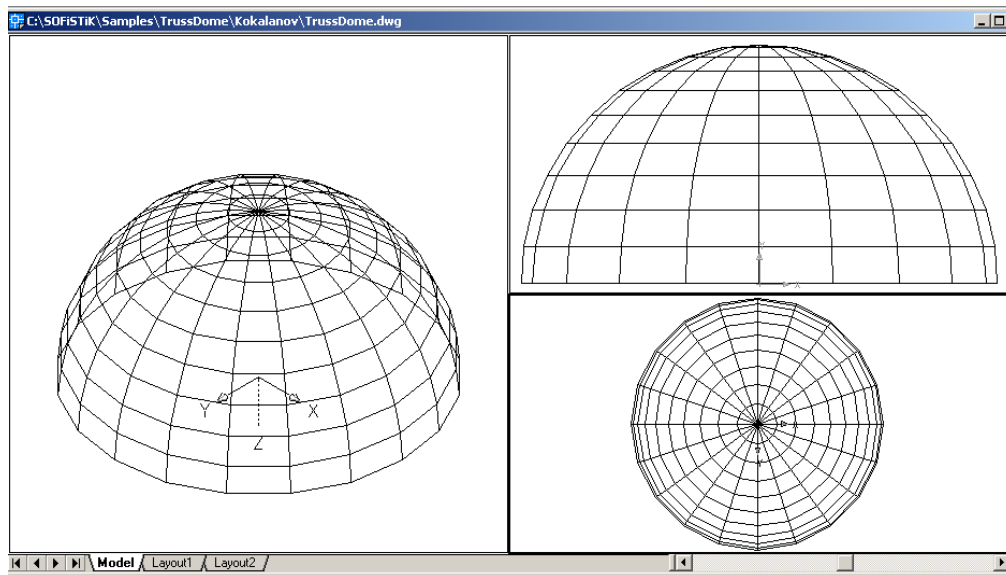

9.2 STRUCTURAL SYSTEM

Structural system is spatial (*Space*). Analysis is performed according EuroCode (EC 2).
Structural system is revived with:



ICON: Structural system
MENU: SOFiPLUS → Structural system...
Command: SOF_GSYSMOD

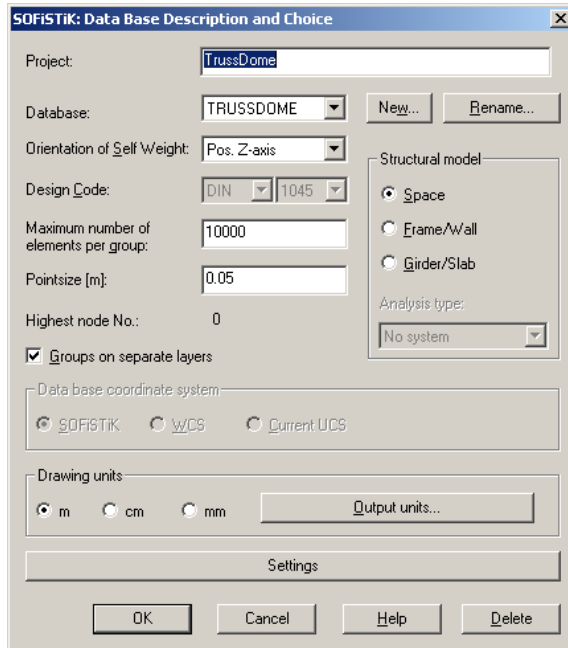

SOFiSTIK: Data Base Description and Choice

Project:

Database:

Orientation of Self Weight:

Design Code:

Maximum number of elements per group:

Pointsize [m]:

Highest node No.:

Groups on separate layers

Data base coordinate system:
 SOFiSTiK WCS Current UCS

Drawing units
 m cm mm

Settings

Appointed parameters for structural system and database are:

Project	TrussDome
Database	TRUSSDOME
Orientation of Self Weight:	Pos. Z axis
Design Code	DIN 1045
Maximum number of element per group	10000
Point size	0.05
Structural mode	Space
Database coordinate system	SOFiSTiK
Drawing units	m

9.3 MATERIAL

The material for the slab is standard structural steel



ICON: Material
 MENU: SOFiPLUS →Defined model→Material
 Command: SOF_GSYMATE

Acquired material is:

Structural Steel	ST 37 (DIN 17100)
------------------	-------------------

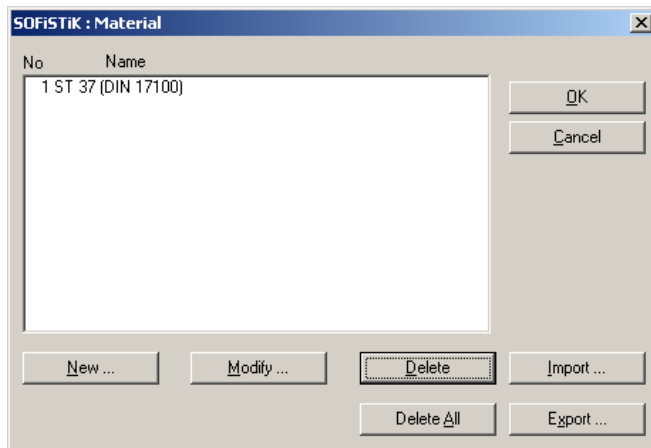

9.4 CROSS SECTIONS

Two types of cross section are used in the structure: tubular profile D=70/2 mm and D=51/2 mm.



ICON: Cross Section
 MENU: SOFiPLUS →Defined model→Cross Section
 Command: SOF_GQUER

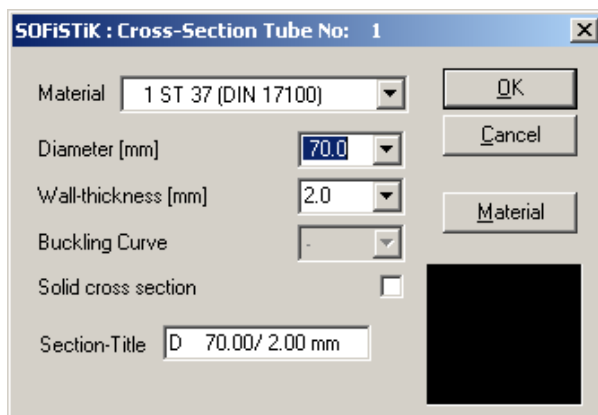

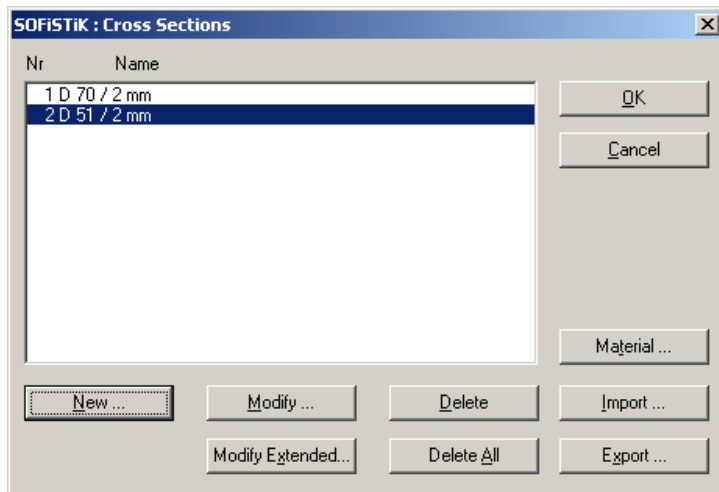

9.5 FINITE ELEMENT MESH

Two types of finite elements are used in the mathematical model of the structure: truss and shell. First, shell element are generated. Finite element mesh density is determined during drawing the surface.

Enter number of longitudinal segments for surface of dish <16>: **20** (20 segments along the dish lenght)

Enter number of latitudinal segments for surface of dish <8>: **10** (10 segments in meridian direction)

Shell finite element mesh will be created with objects.



ICON: Generate with Objects
 MENU: SOFiPLUS →Generate→With Objects
 Command: SOF_GNETGEN

Select *QUAD Area elements* from the dialogue box, and enter 5 in the group number edit box. It indicates that all shell elements belong to group 5 i.e. their number starts from 50000 (5·10000 maximum number of elements per group)

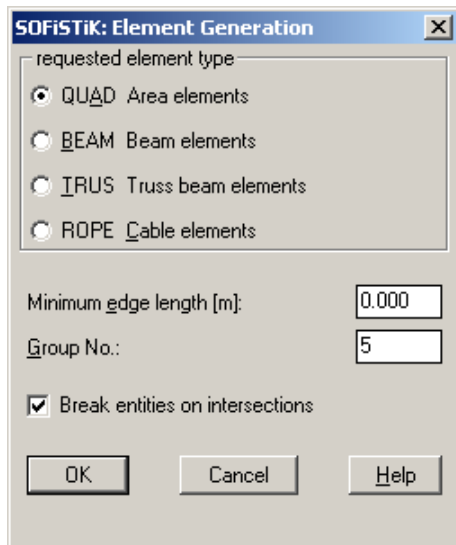

Select the mesh during drawing the shell. On the following message:



answer with Yes.

First Element number<50000>: **Return**

Accept offered number for numeration the first node in the group. Program converts the mesh in shell finite elements. Exception is made in the upper part of the dome where mesh concludes with triangular elements.

++++ ERROR: Spurious 3-D-Element can not be converted to a QUAD

Opening is positioned in the upper part of the dome and you should not cover it with finite elements.

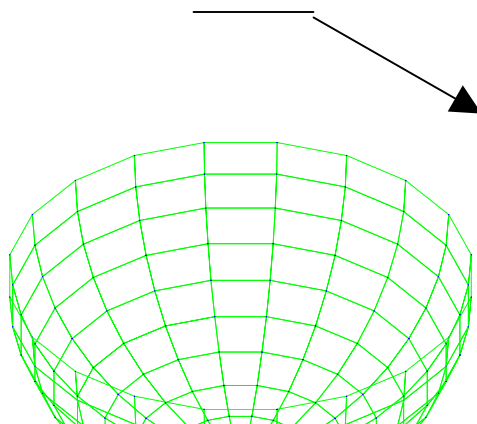

9.6 CORRECTION OF FINITE ELEMENT MESH

Let the opening be larger and extend to the first group of finite elements. Opening is enlarged by deleting finite elements from the uppermost segment of the shell. Deletion is done with simple AutoCAD command *Erase*.

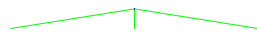

Command: **erase**

Select objects: (Click on point P1)

Specify opposite corner: (Click on point P2)

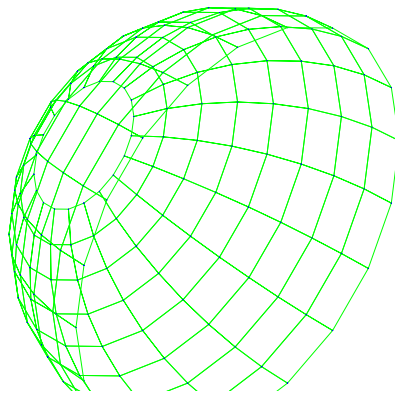

Truss elements will be created with the command:

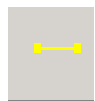

ICON: Truss element

MENU: SOFIPLUS→Create finite element→Truss element

Command: SOF_GFACH

First, elements on meridian direction are created.

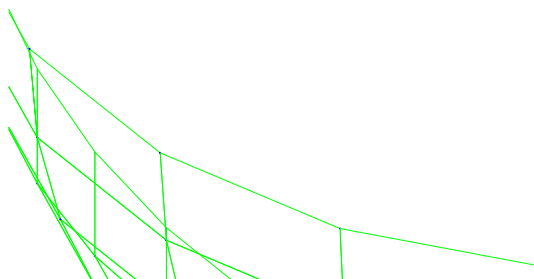

Command:

Node NA (end+mid+cen+nod+int+ins): (Click on point PA)

Node NE (end+mid+cen+nod+int+ins): (Click on point PE)

Section number<1> or [Prestress force]: **Return**
(accept proposed number of cross section)

First Truss beam No.<1>:
(accept proposed element start number)

Node NA (end+mid+cen+nod+int+ins):
(continue with the next meridian elements)

Node NE (end+mid+cen+nod+int+ins):

Then, generate horizontal segments, but only in range of one segment.

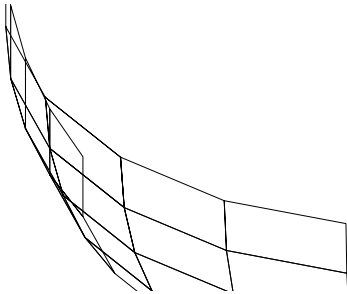

In the end, generate diagonal segment bars. For these bars number of cross section is 2.

Section number<1> or [Prestress force]: **2**

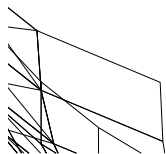

With help of the command *Array* you are able to create truss elements for whole structure. To simplify selecting the elements, make invisible all layers, except layer with truss elements X00FACH_TRUSSDOME.

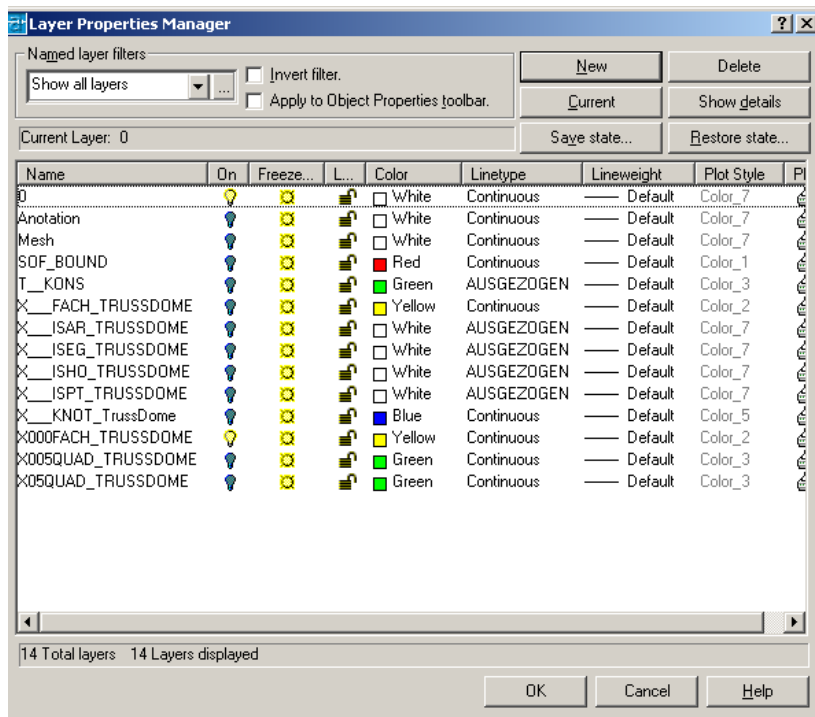

Activate the command *Array* and enter the data according the copy of polar mesh and data entered in dialogue box.

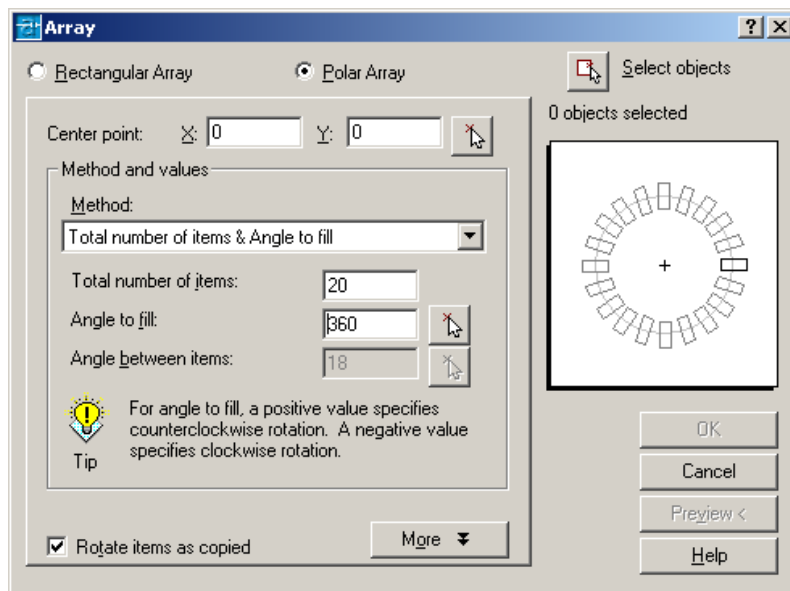

Select already generated truss elements.

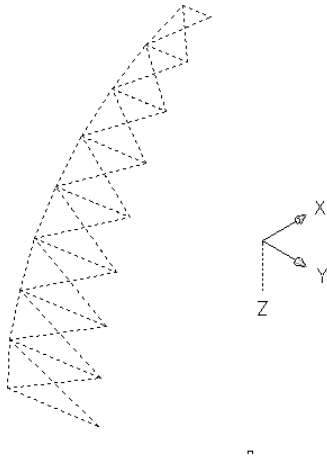

and perform the copy process.

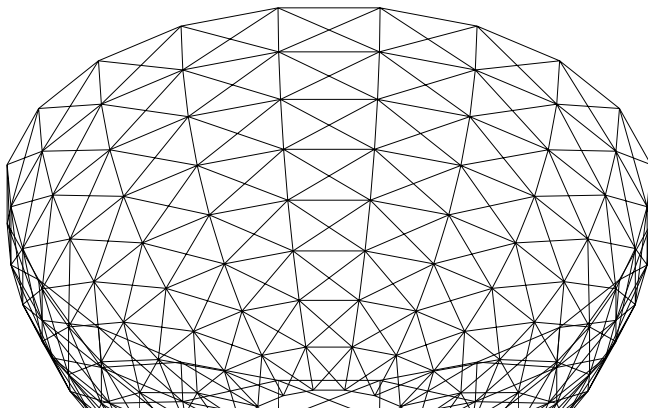

9.7 SUPPORTS

Shell is supported on the bottom ring. Nodes in that part have limited displacements in direction of all three axes.



ICON: Modify Node
 MENU: SOFiPLUS→Defined model→Modify Node
 Command: SOF_GKNOTMOD

Select support points.

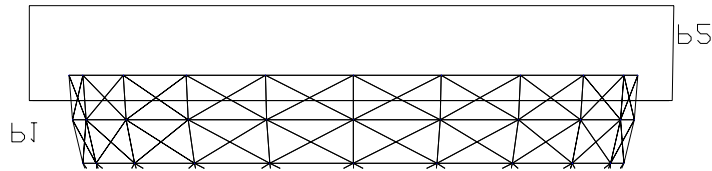

Enter conventional displacements.

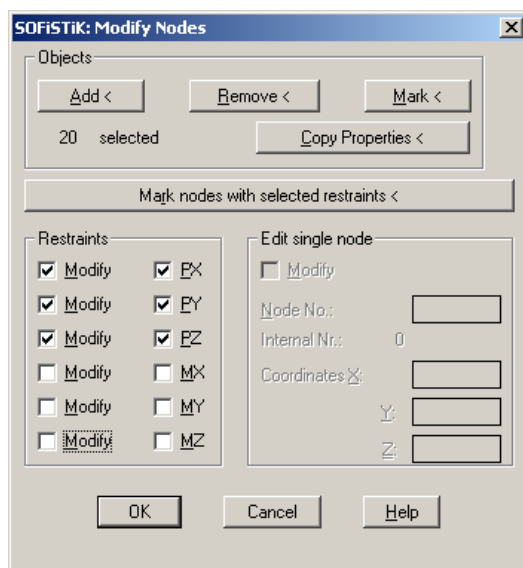

To control the supports, make restraints visualization.



ICON: Display Restrains
 MENU: SOFiPLUS→Visualize→Restrains
 Command: SOF_GFEST

You can fulfill particular adjustment in appearance of the supports.

Command: **SOF_GFEST**
 Loading blocks for restraint symbols
 Settings? [Yes/<No>]: **Y**

In this example, select red color and symbol size of 1.00 m.

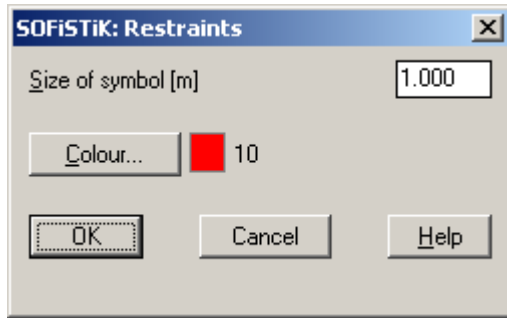

Supports are displayed on the drawing.

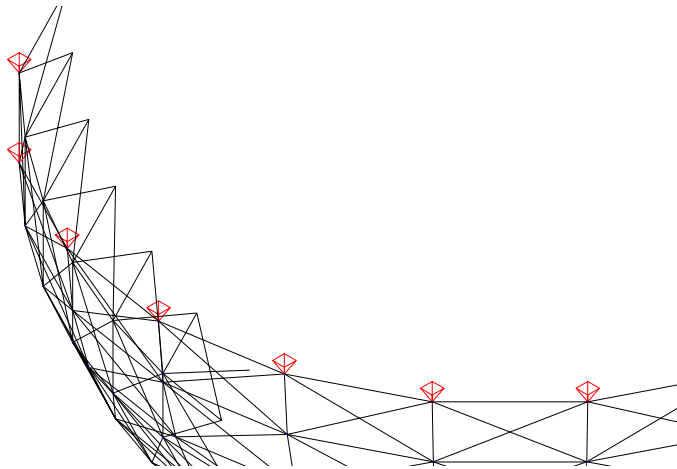

In certain situations, supports may overload the drawing. To hide the supports, you should switch off the layer XV__FEST_TRUSSDOME or use the command:

SOFIPLUS→Visualize→Delete Visualization

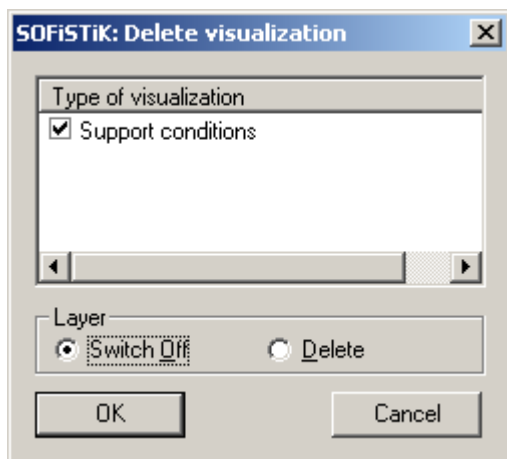

9.8 MODIFICATION OF SHELL ELEMENTS

By definition, you should generate shell elements with default thickness (0.20 m) and material (1). In this example, shell elements have no structural meaning. They are inputted only to limit

the space and to transfer the load from self weight, wind and snow on structural elements. Removing elements from the structure stiffness can be made on several methods.

Accept small shell thickness, for example 0.01 m. For that purpose modify shell elements.



ICON: Modify Area Element
 MENU: SOFiPLUS→Defined model→Modify Node
 Command: SOF_GKNOTMOD

Select all shell elements and enter new thickness in the dialogue box.

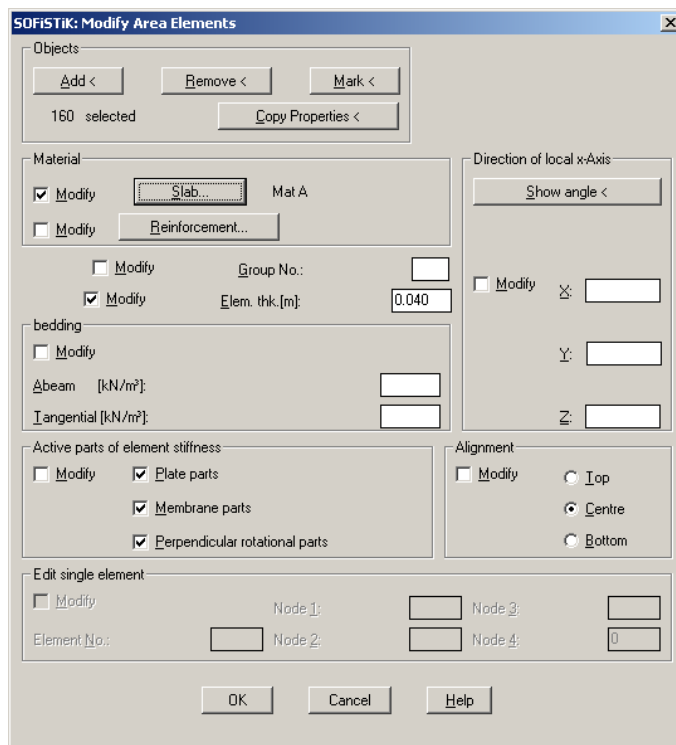

You should input new material that has small modulus of elasticity. Click on the *Slab* command button in the dialogue box. After that, click on the *New* button in the *Material* dialogue box to create new material.

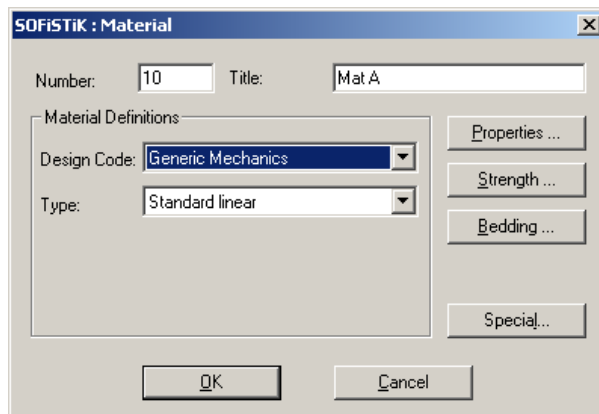

Declare a name for the new material and click on the button *Properties...* to enter material properties.

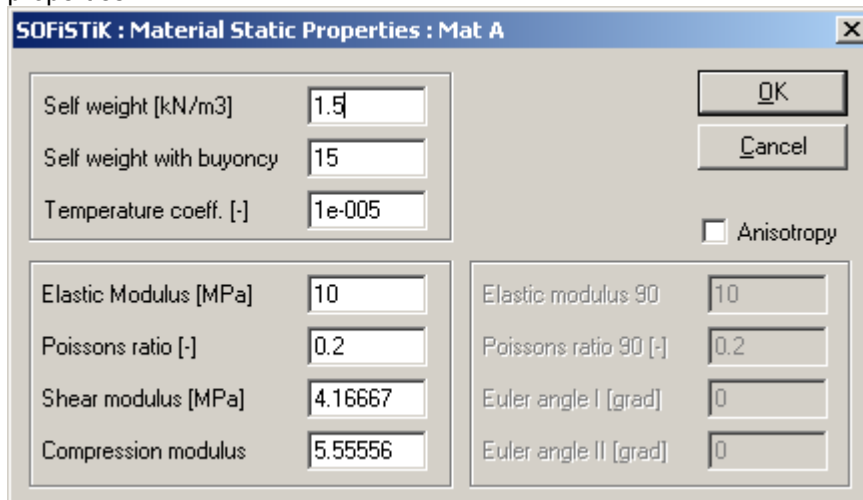

The dialog box 'SOFISTiK : Material Static Properties : Mat A' contains the following fields and controls:

- Self weight [kN/m³]: 1.5
- Self weight with buoyancy: 15
- Temperature coeff. [-]: 1e-005
- Elastic Modulus [MPa]: 10
- Poissons ratio [-]: 0.2
- Shear modulus [MPa]: 4.16667
- Compression modulus: 5.55556
- Elastic modulus 90: 10
- Poissons ratio 90 [-]: 0.2
- Euler angle I [grad]: 0
- Euler angle II [grad]: 0
- Buttons: OK, Cancel
- Checkbox: Anisotropy (unchecked)

Self weight [kN/m³] 1.5
Elastic Modulus [MPa] 10 small value.

During structure analysis make sure not to adjoin stiffness of shell elements in the overall structure stiffness. Click to clear check boxes in the dialogue box that belong to the group *Active parts of element stiffness*.

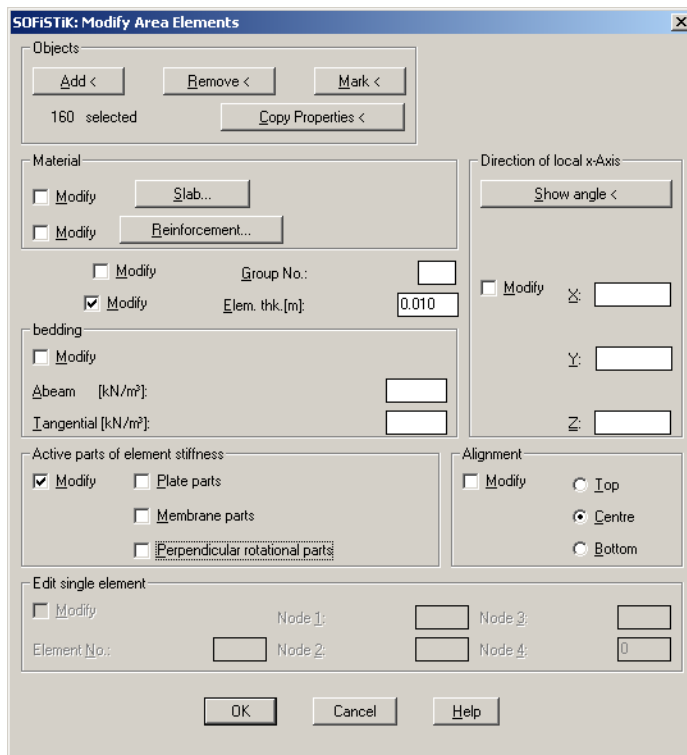

The dialog box 'SOFISTiK: Modify Area Elements' contains the following sections and controls:

- Objects:** Add <, Remove <, Mark <, 160 selected, Copy Properties <
- Material:**
 - Modify Slab... (unchecked)
 - Modify Reinforcement... (unchecked)
 - Modify Group No.: (empty)
 - Modify Elem. thk. [m]: 0.010 (checked)
- bedding:**
 - Modify (unchecked)
 - Δbeam [kN/m²]: (empty)
 - Δtangential [kN/m²]: (empty)
- Direction of local x-Axis:**
 - Show angle <
 - Modify X: (empty)
 - Y: (empty)
 - Z: (empty)
- Active parts of element stiffness:**
 - Modify (checked)
 - Elate parts (unchecked)
 - Membrane parts (unchecked)
 - Perpendicular rotational parts (unchecked)
- Alignment:**
 - Modify (unchecked)
 - Top (radio button)
 - Centre (radio button, selected)
 - Bottom (radio button)
- Edit single element:**
 - Modify (unchecked)
 - Node 1: (empty) Node 3: (empty)
 - Element No.: (empty) Node 2: (empty) Node 4: 0
- Buttons: OK, Cancel, Help

Also this procedure can be conducted in the *TEDY* module as additional command in *PROGRAM ASE*. This process will be explained *STRUCTURE ANALYSIS* chapter.

9.9 INFORMATION / MODIFICATION OF STRUCTURAL ELEMENTS

INFO/EDIT

With INFO/EDIT command you are able to review main properties of structural elements with possibility to modify them if necessary.



ICON: Info/Edit
 MENU: SOFIPLUS→Info/Edit...
 Command: SOF_GINFO

Select structural element that you want to get information i.e. you want to modify. Dialogue box is called up on the screen where all information about selected element are shown. If previously selected element belongs to more structural elements, only information about one element are shown.

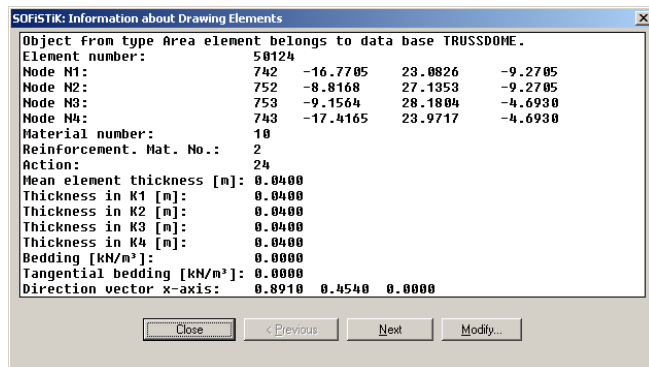

With the button *Help* information about the next element, which has mutual edge with selected, are shown. By moving forward (*Next*) or backward (*Previous*) you can locate element you want to review information.

9.10 LOADING

Define all load cases. In the example, default loads are accepted:

Roof weight	1.50 kN/m ³
Snow	0.75 kN/m ²
Compression wind	0.40 kN/m ²
Sucking wind	0.20 kN/m ²
Equipment weight	1.00 kN/m' along contour of the upper ring
Temperature	30°



ICON: Loadcase Manager
 MENU: SOFIPLUS→Loadcase Manager
 Command: SOF_GLFMOD

Enter load cases with the button *New*.

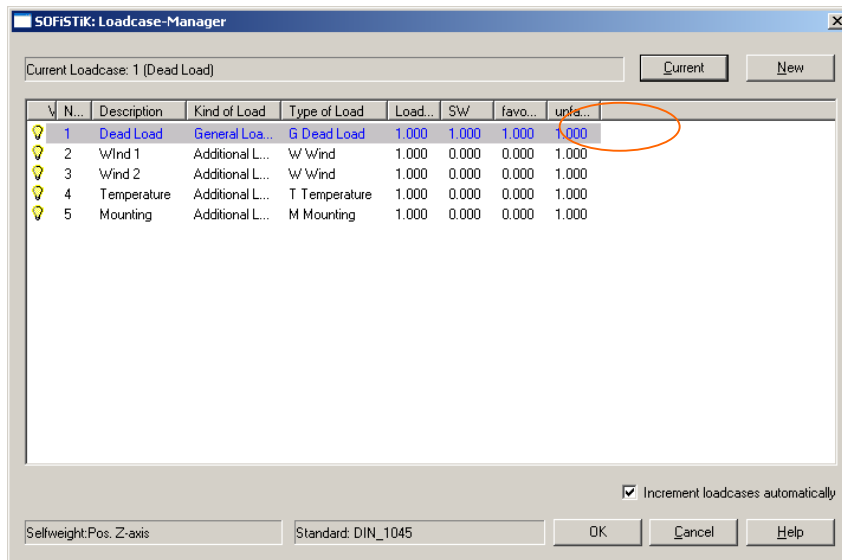

9.10.1 Dead Load

With *Load Manager* make the first load case current. Select the first load case and click on the *Current* button.

In the load case 1 Dead Load, self weight is entered automatically by declaring value 1.00 (100%) to the factor SW. If in other load cases, you need to enter only percentage of the self weight, you can accomplish that by entering proper value for the factor SW.

The weight of the steel profiles will be derived by multiplying the area with weight on m'. Roof structure will be calculated as product in multiplying roof weight (shell element) on m³ and height of shell elements.

9.10.2 Wind 1

Acts on the front side of the shell. It is a load that acts in direction of global X-axis and on whole element area. Before applying loads on elements, make the second load case current. After that, apply the loads that act on area elements.



ICON: Element Loads
 MENU: SOFiPLUS→Create Loads→Element Loads
 Command: SOF_GQLAS

Command: **SOF_GQLAS**

Area elements to be loaded

Select objects: Specify opposite corner: 426 found

362 were filtered out.

Select objects: 1 found, 70 total

Select objects: **Return**

(elements from the front half of the dome are selected)

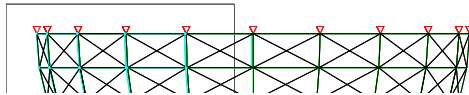

Load type [Load/Mass/Strain/CURvature/Temperature/Prestress/CReep]: **L**
 Load [PX/PY/PZ/PXP/PYP/PZP/PXX/PYY/PZZ]: **PX**
 Load value in kN/m²: 0.40
 Load growth in z-direction<0.0000>: **Return**

9.10.3 Load 2

Make the third load case current and, as done before, apply loads on the rear side of the dome, Px with intensity 0.2 kN.

Command: **SOF_GQLAS**
 Area elements to be loaded
 Select objects: Specify opposite corner: 426 found
 362 were filtered out.
 Select objects: 1 found, 70 total
 Select objects: **Return**
 (elements from the rear half of the dome are selected)

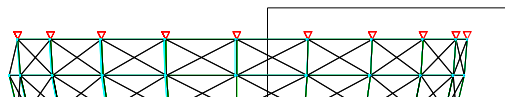

Load type [Load/Mass/Strain/CURvature/Temperature/Prestress/CReep]: **L**
 Load [PX/PY/PZ/PXP/PYP/PZP/PXX/PYY/PZZ]: **PX**
 Load value in kN/m²: 0.20
 Load growth in z-direction<0.0000>: **Return**

9.10.4 Snow

Snow is a load that acts vertically on horizontal unit area. Make the fourth load case current. Activate aging the command **SOF_GQLAS**, and select all dome elements and apply force PZP with intensity 0.75 kN/m².

Command: **SOF_GQLAS**
 Area elements to be loaded
 Select objects:
 (select all dome elements)

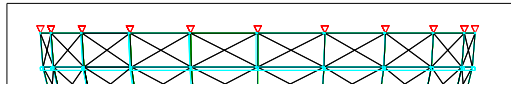

Load type [Load/Mass/Strain/CURvature/Temperature/Prestress/CReep]: **L**
 Load [PX/PY/PZ/PXP/PYP/PZP/PXX/PYY/PZZ]: **PZP**
 Load value in kN/m²: 0.75
 Load growth in z-direction<0.0000>: **Return**

NOTE: To simplify selection of elements, it is eligible to hide temporary already created loads. It performed by the command:

SOFIPLUS→Visualize→Delete Visualization

In the dialogue box, check the *&Loads* check box and click to select *Switch Off*.

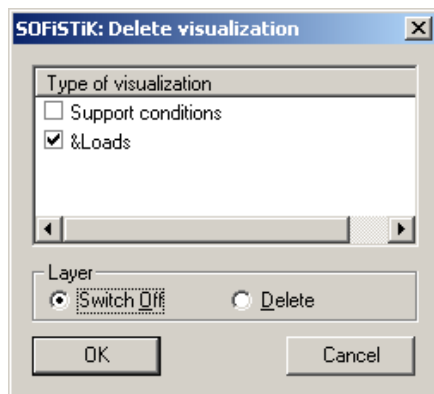

9.10.5 Installation

Forces from installation act as uniformly distributed line load along the length of the uppermost dome ring. After you select fifth load case (*Mounting*), activate the command:



ICON: Boundary Loads
 MENU: SOFIPLUS→Create Loads→Boundary Loads
 Command: SOF_GRLAS

This command requires sequence input of nodes that receive the line load.

Command: **SOF_GRLAS**

Start node (end+mid+cen+nod+int+ins): <Osnap on>

next node (end+mid+cen+nod+int+ins):

Select additional intermediate nodes **Return**

next node (end+mid+cen+nod+int+ins):

Select additional intermediate nodes **Return**

(select all nodes from the uppermost ring)

Load type [PX/PY/PZ/PXP/PYP/PZP/PS/MX/MY/MZ/M]: PZ
Load value in kN/m Start: 1.00
Load value in kN/m End<1.0000>:

9.10.6 Temperature

Make Load case 6 Temperature current. Activate again the command:



ICON: Element Loads
MENU: SOFiPLUS→Create Loads→Element Loads
Command: SOF_GQLAS

Command:

Area elements to be loaded

Select objects:

(select all structure elements)

Load type <Load>[Load/Mass/Strain/CURvature/Temperature/Prestress/CReep]: T

Load [TEMP/DT]: TEMP

Load value in °C<0.7500>: 30

9.11 DATABASE EXPORT

Drawing data have to be transferred into analysis database, wherefrom the rest modules will get necessary information.



ICON: SOFiPLUS→Export
MENU: SOFiPLUS→Analysis Data Base (CDB)→Export(..
Command: SOF_GENFOUT

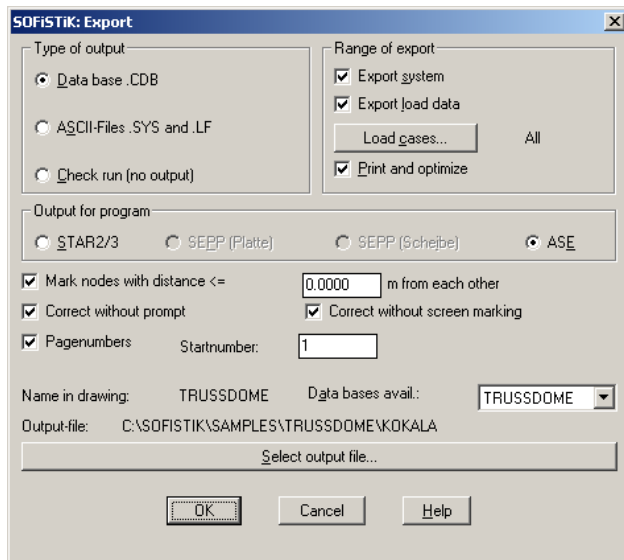

9.12 STRUCTURE ANALYSIS

Analysis of the structure is done in the program *WTEDY*.



ICON: Edit (Win Ted)
 MENU: SOFiPLUS→Analysis ...
 Command: SOF_G

At the first start of this module, a dialogue box is called up where you should enter input file name.

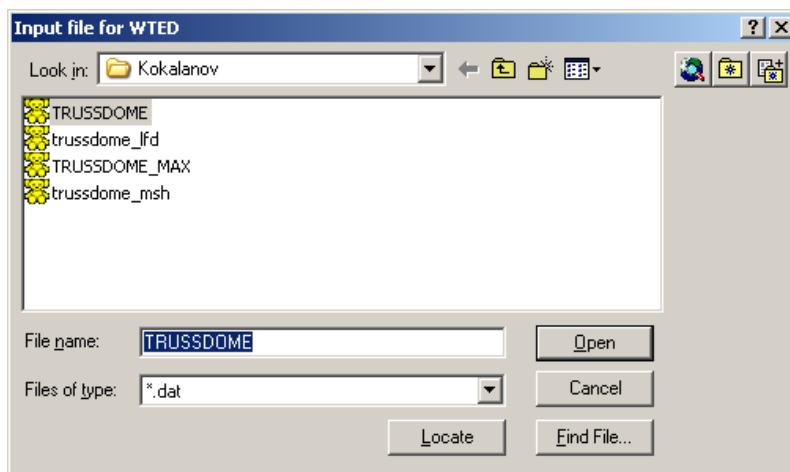

In this example it is the file TRUSSDOME.DAT. After you select the file, working environment of the program *WTED* is shown. Program disposes of large number of functions which control the calculation and commit selection and method of viewing the results. By activating this working environment, input file is loaded in the editor. This file can be additionally modified in order to load certain operations not enclosed with the default options or to change the parameters of the default options.

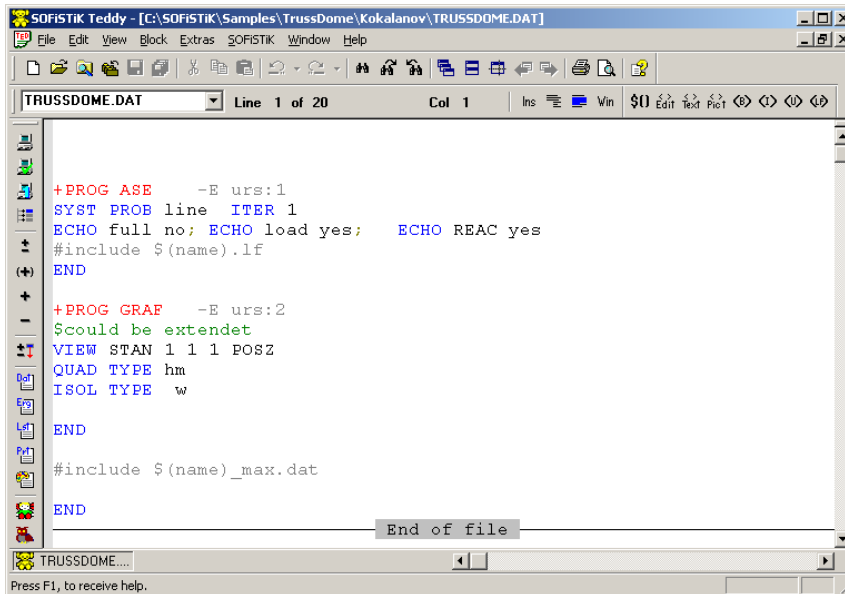

```

+PROG ASE      -E urs:1
SYST PROB line ITER 1
ECHO full no; ECHO load yes;   ECHO REAC yes
#include $(name).lf
END

+PROG GRAF    -E urs:2
$could be extendet
VIEW STAN 1 1 1 POSZ
QUAD TYPE hm
ISOL TYPE w
END

#include $(name)_max.dat

END
    
```

In previous chapters, process of turning off the stiffness of the shell elements was explained by using small modulus of elasticity or small shell thickness. In continuance, this process is explained in module *ASE* (module for 3D structure analysis). Enter the command:

GRP 5 OFF

that turns off elements from the group 5 (shell elements)

```



+PROG ASE M80 -E urs:1
SYST PROB LINE ITER 1
ECHO FULL NO; ECHO LOAD YES; ECHO REAC YES
GRP 5 OFF
#include $(name).lf
EIGE 10 LC 101
END
    
```

From the input file, it is obvious that the calculation process can be activated by two program modules: *ASE* and *GRAF*. The list of default program modules is determined by the selected structure model. You can extend the list, or you can remove certain modules that are not in analysis interest.

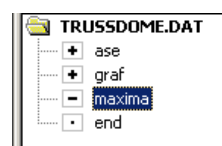
In the list of modules:



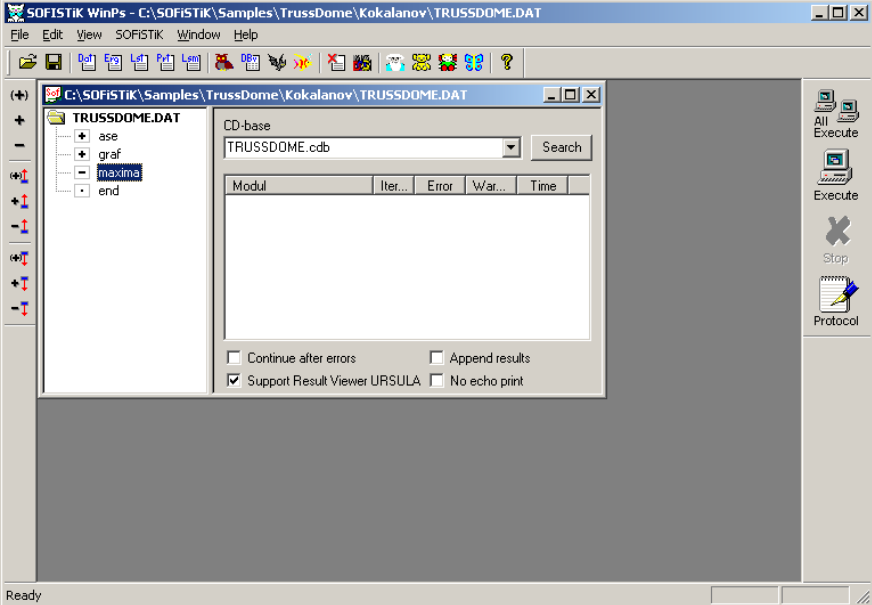

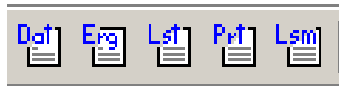

the sign “+” denotes that a module is included in the analysis. Module can be removed from the analysis by changing the sign in “-“ (click on the sign “+”). Thus, user is able to control the programs which participate in the calculation. Three separate icons start the calculation process:

	<p>Starts the WinPs module which allows control of the computation process.</p> 
	<p>Starts the calculation immediately. All marked modules will execute.</p>
	<p>Only module in which cursor is positioned, will execute.</p>

During the analysis, several text files are created which contents are possible to view by the following icons:



	<p>TRUSSDOME.DAT - input file formed by exporting the database and can be modified in <i>TEDY</i>.</p>
	<p>TRASSDOME.ERG - file that contains loads and reactions data</p> <pre> SOFISTIK AG * License No. 4140:001 ASE - ADVANCED SOLUTION ENGINE (V11.01-99) 5/30/02 TrussDome DEFINITION OF LOAD TYPE IN THIS OUTPUT: PZZ - load in global direction Z in reference to the element 1 PZP - load in global direction Z in reference to the projection Pz - load in local direction z PG - load in dead load direction in reference to the element LOAD CASE 1 (G) Dead Load Factor forces and moments 1.000 Factor dead weight DL-ZZ 1.000 unfavourably safety factor 1.000 favourably safety factor 1.000 </pre>
	<p>TRUSSDOME.Lst</p>

	<p>TRUSSDOME.PRT- file that contains output files data</p> <pre> *** Start: Program WinPs - Version 99.4.5.8 *** Start: Program ASE ASE - ADVANCED SOLUTION ENGINE - VERSION: 11.01-99 Windows_NT Input file TRUSSDOME.#01 Output on file trussdome.lst Grafic output on file trussdome.plb 121 status 0 CDBase is working multi-user-/multi-task-mode Memory allocated : 512 datablocks with length 540 Project data base .\trussdome.cdb - 14. access Project:TrussDome Projectfile .\trussdome.\$d1 status 1 unit 101 Projectfile .\trussdome.\$d2 status 1 unit 102 Projectfile .\trussdome.cde status 0 unit 103 Projectfile .\trussdome.\$d4 status 0 unit 104 Workspace 5.7 Megabyte loadcase 1 loadcase 2 loadcase 3 loadcase 4 loadcase 5 </pre>
	<p>TRUSSDOME.Lsm</p>

9.13 DISPLAYING NODE/ELEMENT

If during the analysis program displays errors then the messages for those errors are usually connected with the node or element where they appear. At large structures with plenty of elements and nodes it is very difficult to find directly the needed element/node. The right module for that purpose is *WinGraf* module and its option for displaying elements from the structural system.



ICON: WinGraf

MENU: SOFIPLUS→Graphical output→Graphical output... Command:

For example, if you want to find nodes with the numbers from 750 to 760 from the work area, activate *Result types*:

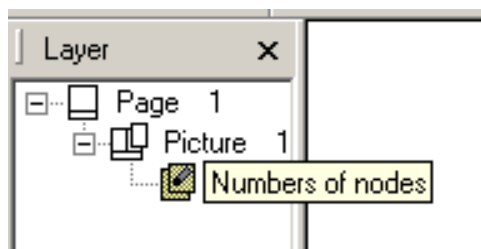

or the icon



Draw System Variables

to open the Draw system-definitions dialogue box, wherefrom you should select Definitions of elements→Numbers of elements.

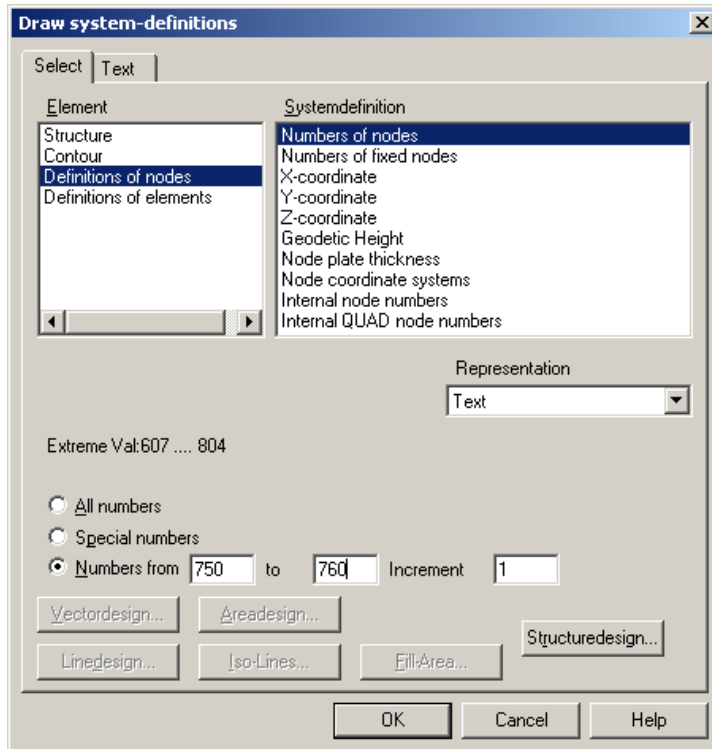

Click on the option *Number from ... to ...*, to enter the range of numbers that you want to display.

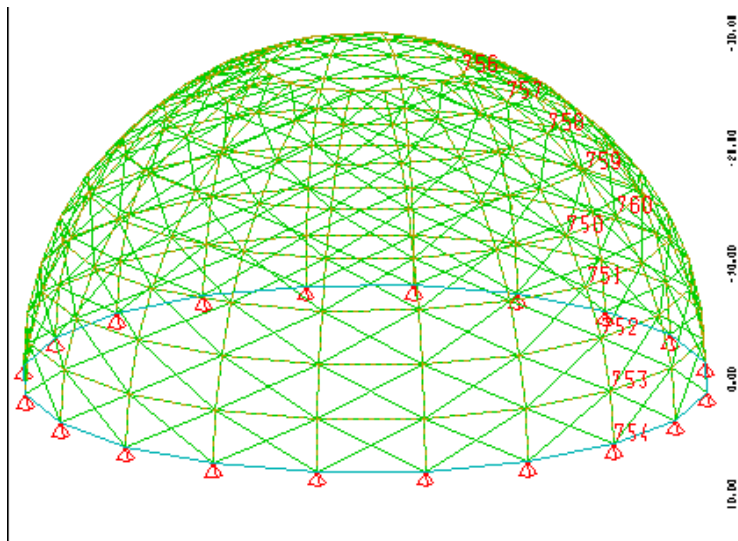

9.14 LOAD CONTROL

Load control can be performed in text files, program *URSULA* or *WinGraf* and its tools for displaying the loads. For example, to display the forces for the load case 2 *Wind 1*, select the option *Area Loads in local components* from the *Result types* work area

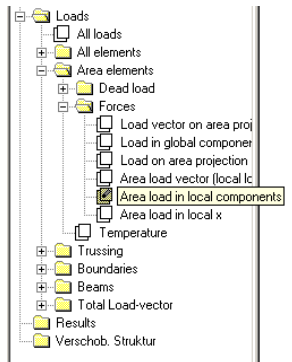

or by clicking on the icon



Draw loads

to call up the *Draw loads* dialogue box and select *Trussing*→*Forces*→*Area Loads in local components*. From the combo box *Loadcase* select 2 Wind 1. Representation is by vectors. *Representation*→*Vector*

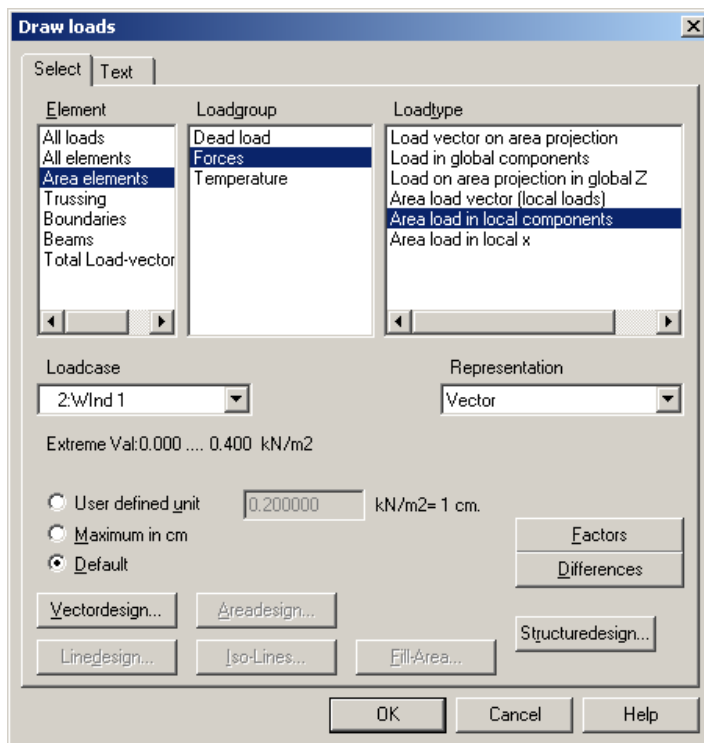

Results from the appointed options are shown on the following picture.

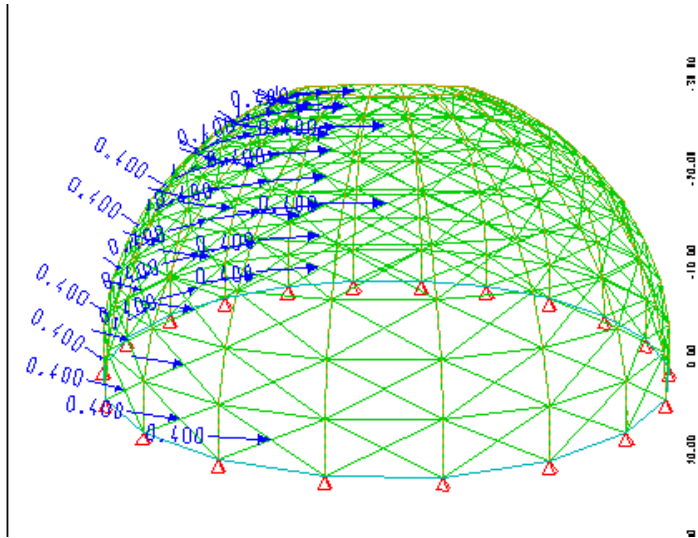

9.15 RESULTS

Results in *WinGraf* are presented by the command:



ICON: Draw Results
MENU: Select→ Draw Results...

or select Results→Trussing→Trussing Normal Forces in the Result types work area.

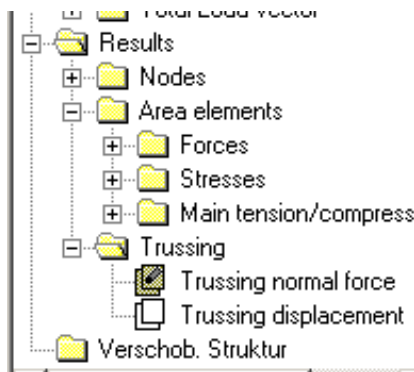

Select the load case in the opened dialogue box to display results and the method for showing the results.

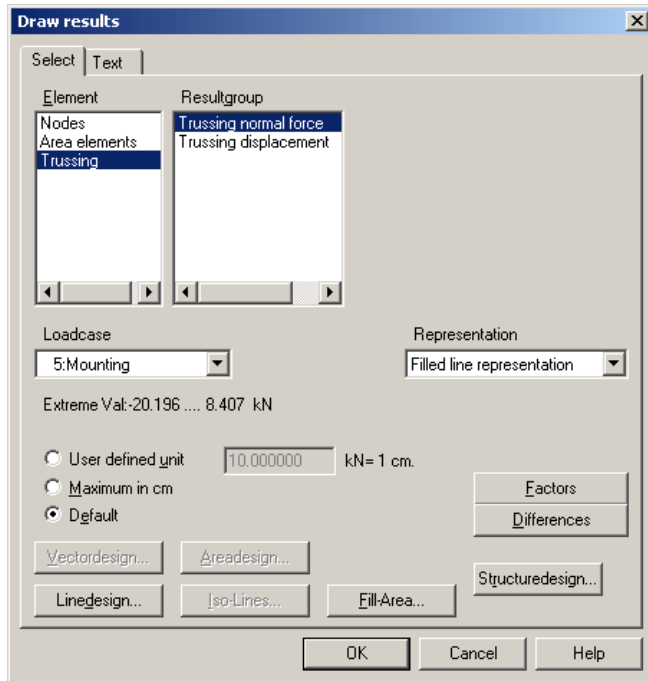

Graphical presentation of the results for the load case 5. *Mounting* is as shown on the following picture:

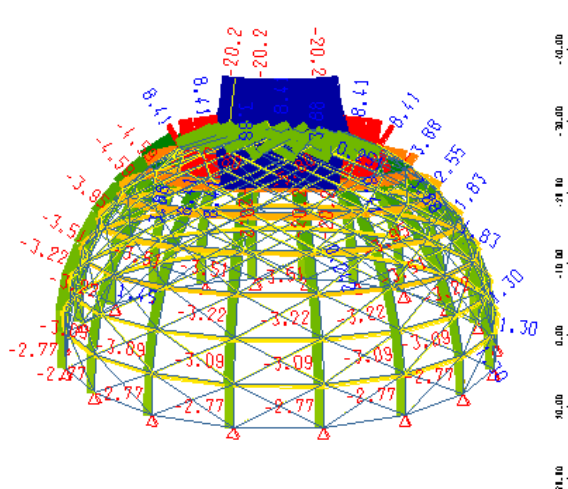

9.16 VISUAL CONTROL ON THE STRUCTURE AND RESULTS

For quick visual control on the structure and its geometry, you should use the program *ANIMATOR*.



In the current example, main interest are truss elements, so it is advisable to hide the shell elements in the structure.



Command - *Shoot one group*, allows to hide the shell elements by clicking on them (shell elements belong to special group 5).

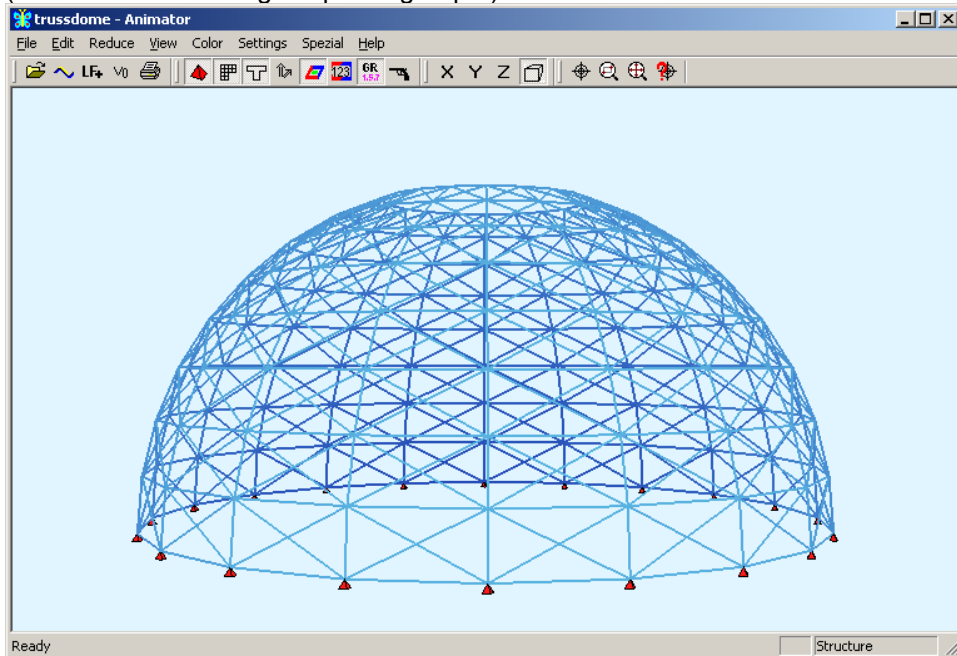

You can obtain deformations from certain load case, by clicking the load case in the combo box which is activated by



Command - Choose loadcase

Select the load case in the following dialogue box, the magnitude, animation speed and picture rotation speed.

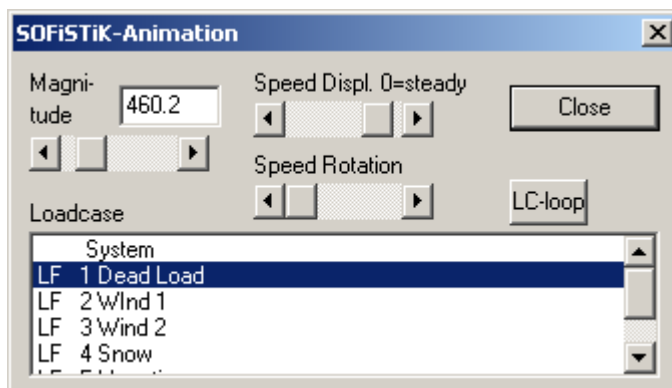

If you select:



Command - Coloured result, beside deformations, the stress alteration in the elements during structure deformation is shown in differed colors. If you click on the icon:



animations stops and representation of the structure deformed shape is displayed.

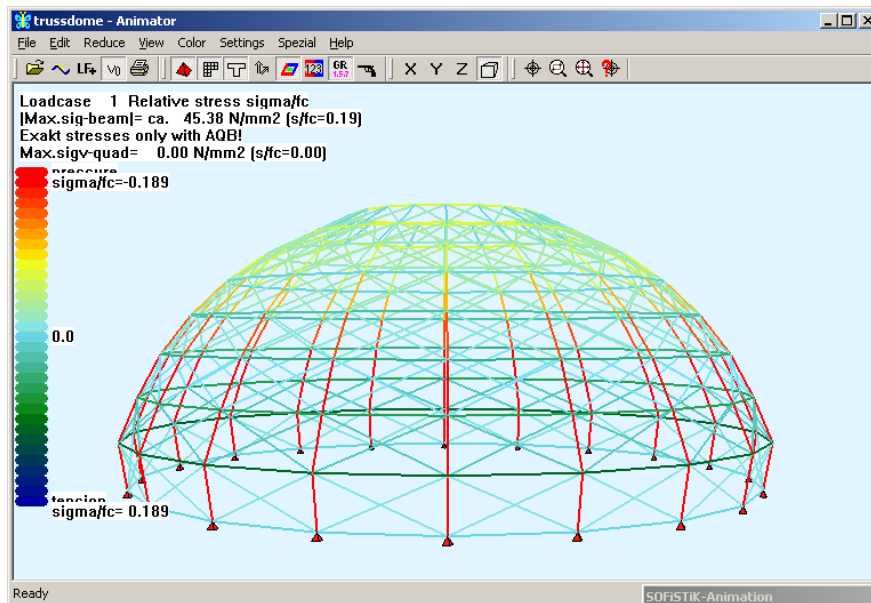

To display static values in particular element, use the tool:



Element info

Click with the target on a element to display information and the forces for the selected element are shown in new window.

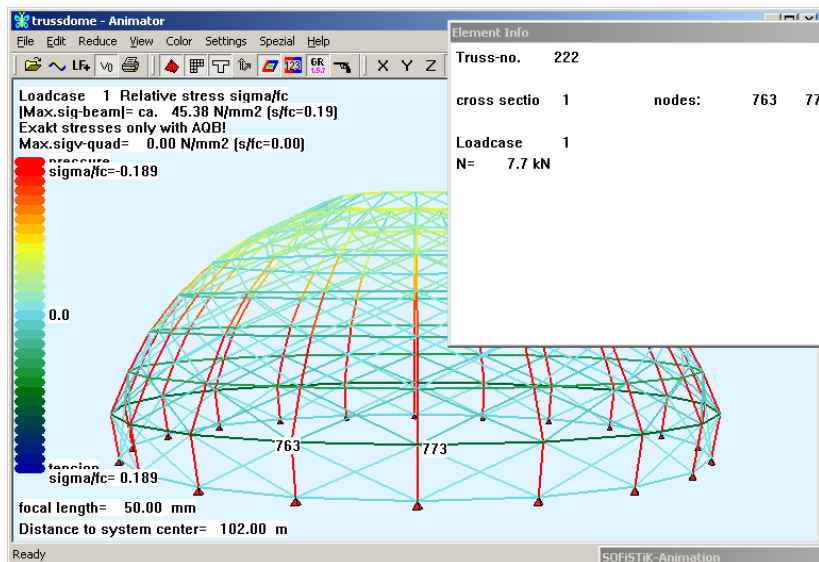

9.17 QUAD ELEMENT LOADING EXAMPLES

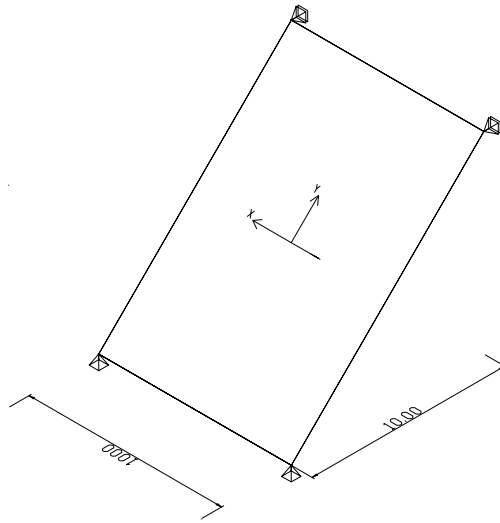

9.17.1 ELEMENT LOADS



ICON: Element Loads
 MENU: SOFiPLUS→Create Loads→Element Loads
 Command: SOF_GQLAS

Command: **SOF_GQLAS**

Area elements to be loaded

Select objects:

Load type <Load>[Load/Mass/Strain/CUrvature/Temperature/Prestress/CReep]: **L**

9.17.2 Uniformly distributed load in local Z-axis direction

Load <PX>[PX/PY/PZ/PXP/PYP/PZP/PXX/PYY/PZZ]: **Pz**

Load value in kN/m²<10.0000>: **10.00**

Load growth in z-direction<0.0000>: **Return**

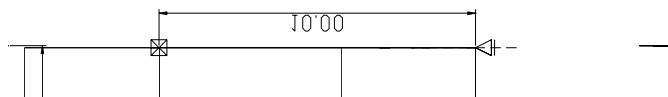

9.17.3 Variable load in local Z-axis direction

Load <PX>[PX/PY/PZ/PXP/PYP/PZP/PXX/PYY/PZZ]: **Pz**
 Load value in kN/m²<10.0000>:**10.00**
 Load growth in z-direction<0.0000>:**1.00** (100% enlarged)

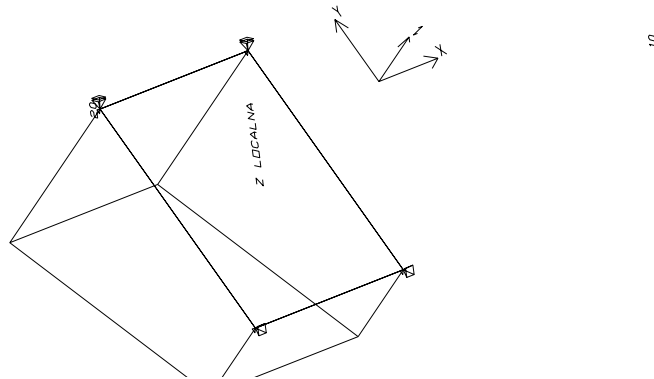

9.17.4 Uniformly distributed load in global X-axis direction - projection

Load <PX>[PX/PY/PZ/PXP/PYP/PZP/PXX/PYY/PZZ]: **PXP**
 Load value in kN/m²<10.0000>:**10**
 Load growth in z-direction<0.0000>:**Return**

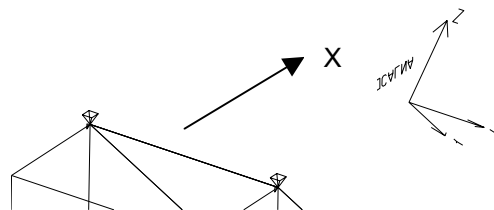

9.17.5 Variable load in global X-axis direction - element projection

Load <PX>[PX/PY/PZ/PXP/PYP/PZP/PXX/PYY/PZZ]: **PXP**

Load value in kN/m²<10.0000>:**10**

Load growth in z-direction<0.0000>:-1 (100%)

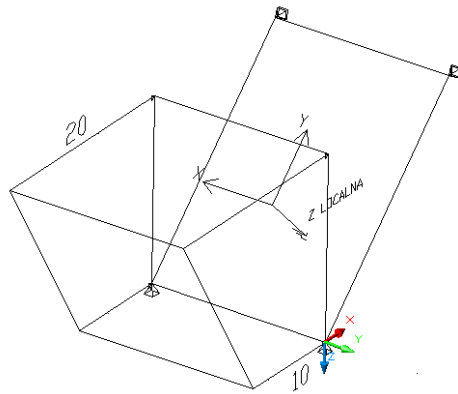

9.17.6 Uniformly distributed load in global X-axis direction

Load <PX>[PX/PY/PZ/PXP/PYP/PZP/PXX/PYY/PZZ]: **PXX**

Load value in kN/m²<10.0000>:**10**

Load growth in z-direction<0.0000>:**Return**

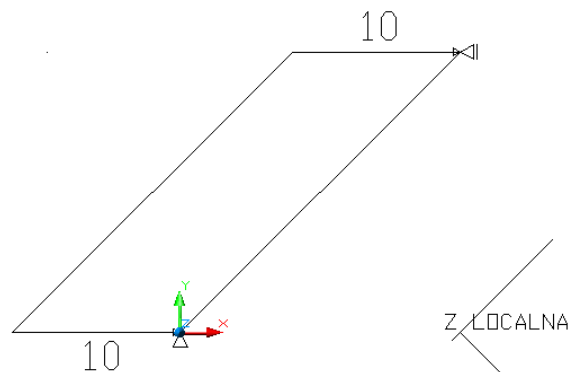

9.17.7 Variable load in global X-axis direction

Load <PX>[PX/PY/PZ/PXP/PYP/PZP/PXX/PYY/PZZ]: **PXX**

Load value in kN/m²<10.0000>:**10**

Load growth in z-direction<0.0000>:-1 (100%)

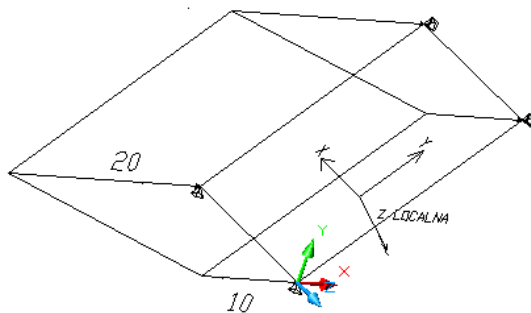



ICON: Free Area Loads
 MENU: SOFiPLUS→Create Loads→ Free Area
 Command: SOF_GBLAS

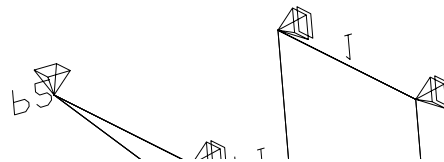

9.17.8 In global X-axis direction

SOFiSTIK: Create free arealload

Load value P1: [kN/m²]	<input type="text" value="10.00"/>	Name of load:	<input type="text"/>
Load value P2: [kN/m²]	<input type="text" value="10.00"/>	Loadcase:	<input type="text" value="1"/>
Load value P3: [kN/m²]	<input type="text" value="10.00"/>	Loadtype: <input type="text" value="Load"/>	<input type="text" value="PXX - global load X"/>
Load value <input type="text" value="P4"/> [kN/m²]	<input type="text" value="10.00"/>	Reference Type:	<input type="text" value="AUTO - automatic"/>
<input type="checkbox"/> simplified Representation	<input checked="" type="checkbox"/> U.D.L.	Group- / reference number:	<input checked="" type="checkbox"/> all
		Direction of projection:	<input type="text" value="ELEM - projected"/>
		Tolerance width:	<input type="text"/>

Use selected entities for new selectionset
 Apply automaticly

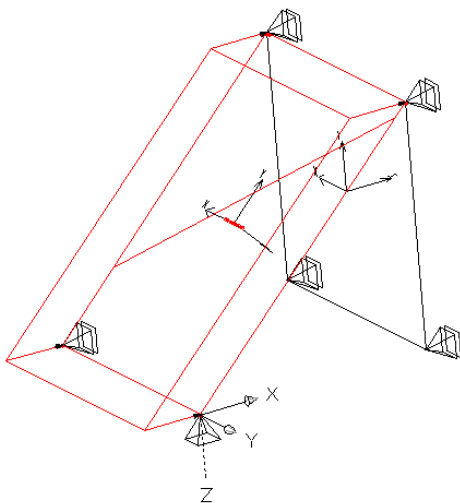

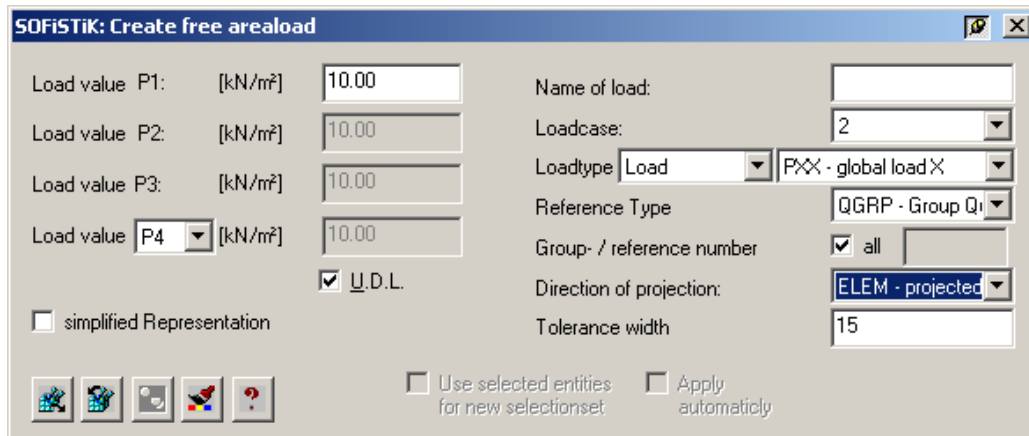
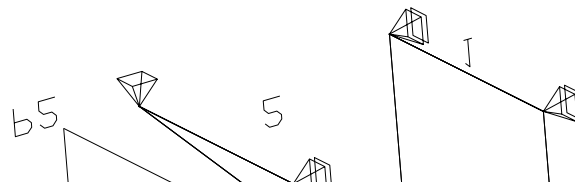

Load acts in P1, P2, P3, P4 plane with depth 15 m on all QUAD element groups.

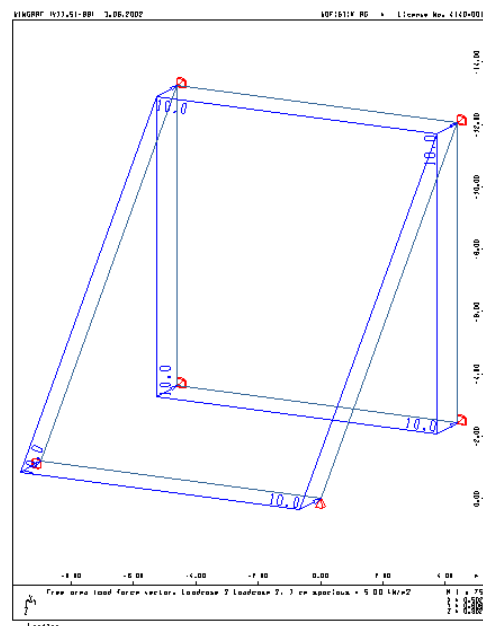
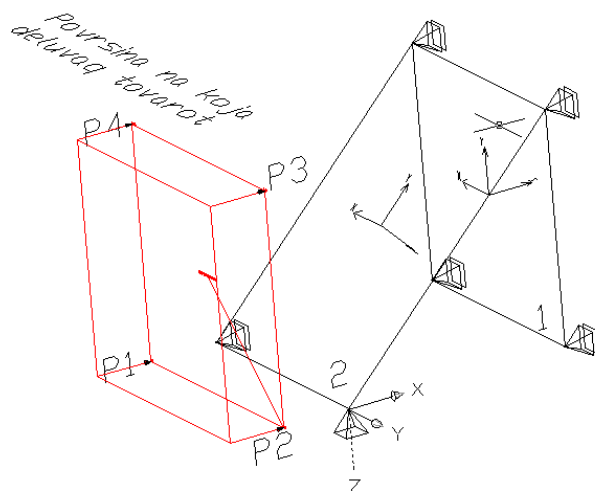

SOFISTIK: Create free areaload

Load value P1: [kN/m²]

Load value P2: [kN/m²]

Load value P3: [kN/m²]

Load value P4: [kN/m²]

U.D.L.

simplified Representation

Name of load:

Loadcase:

Loadtype:

Reference Type:

Group- / reference number: all

Direction of projection:

Tolerance width:

Use selected entities for new selectionset Apply automatically

Load acts only on QUAD elements from the group 1.

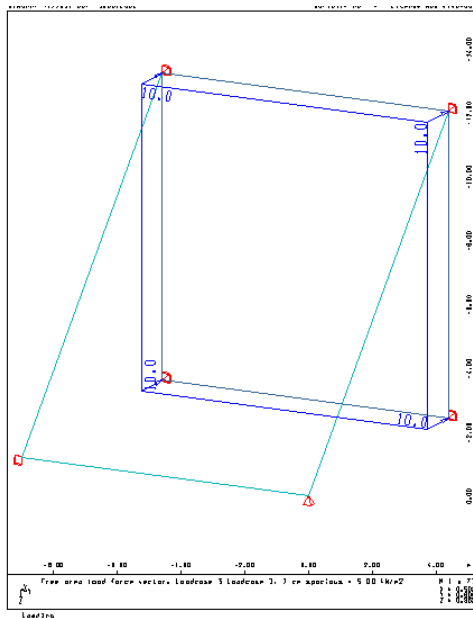

SOFISTIK: Create free areaload

Load value P1: [kN/m²]

Load value P2: [kN/m²]

Load value P3: [kN/m²]

Load value P4: [kN/m²]

U.D.L.

simplified Representation

Name of load:

Loadcase:

Loadtype:

Reference Type:

Group- / reference number: all

Direction of projection:

Tolerance width:

Use selected entities for new selectionset Apply automatically

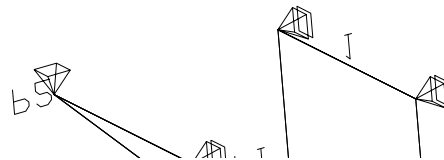
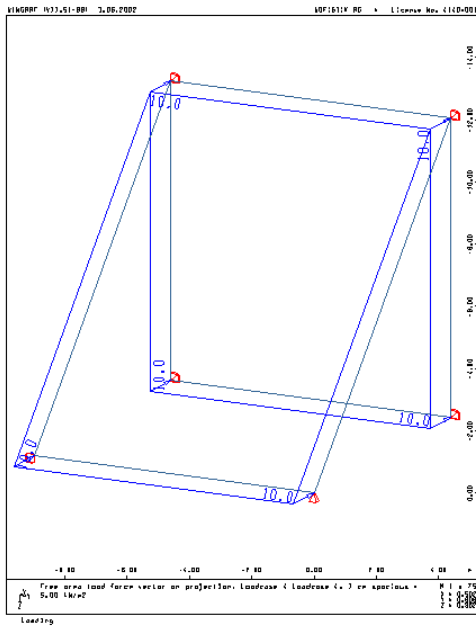

SOFiSTiK: Create free arealload

Load value P1: [kN/m ²]	<input type="text" value="10.00"/>	Name of load:	<input type="text"/>
Load value P2: [kN/m ²]	<input type="text" value="10.00"/>	Loadcase:	<input type="text" value="5"/>
Load value P3: [kN/m ²]	<input type="text" value="10.00"/>	Loadtype	<input type="text" value="Load"/> PZP - global load relatec
Load value P4 [kN/m ²]	<input type="text" value="0"/>	Reference T type	<input type="text" value="QGRP - Group Q"/>
<input type="checkbox"/> U.D.L.		Group- / reference number	<input checked="" type="checkbox"/> all
<input type="checkbox"/> simplified Representation		Direction of projection:	<input type="text" value="ELEM - projected"/>
		Tolerance width	<input type="text"/>

Use selected entities for new selectionset
 Apply automatically

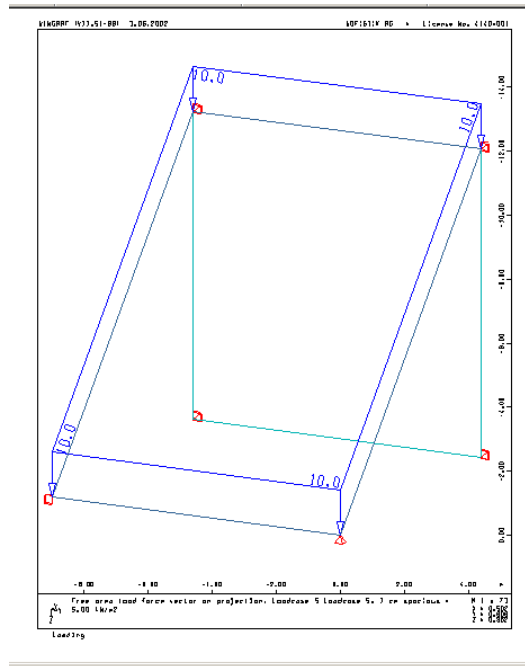

on file WINGRAF.DEF

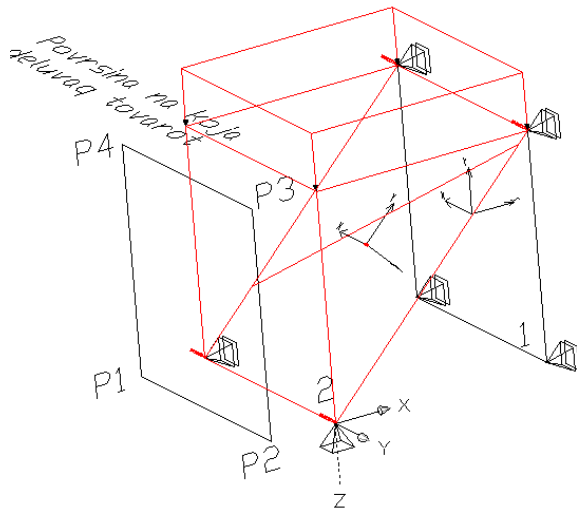

SOFISTIK: Create free areaload

Load value P1: [kN/m²]

Load value P2: [kN/m²]

Load value P3: [kN/m²]

Load value P4: [kN/m²]

U.D.L.

simplified Representation

Name of load:

Loadcase:

Loadtype: PZP - global load related

Reference Type:

Group- / reference number: all

Direction of projection:

Tolerance width:

Use selected entities for new selectionset

Apply automatically

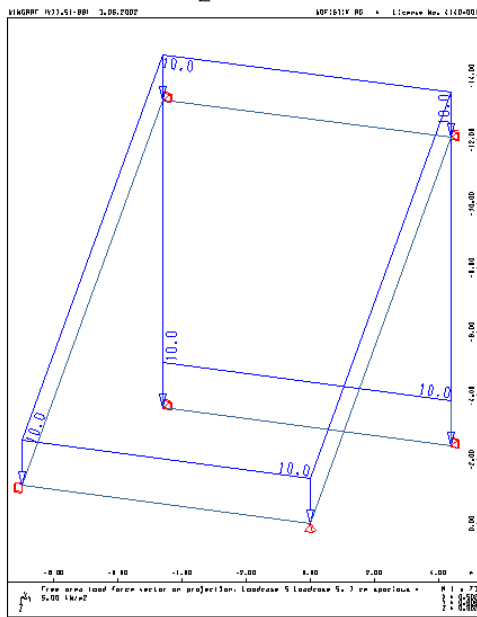
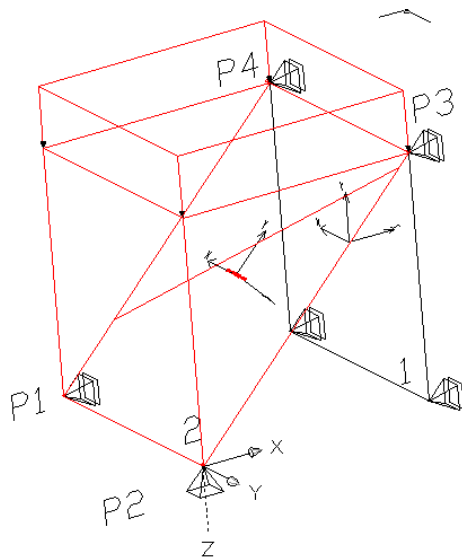

9.18 SHELL ELEMENTS

9.18.1 VERTICAL LOADING PLANE

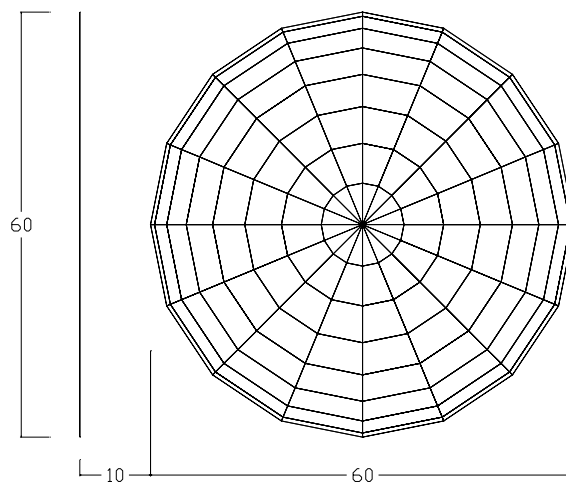

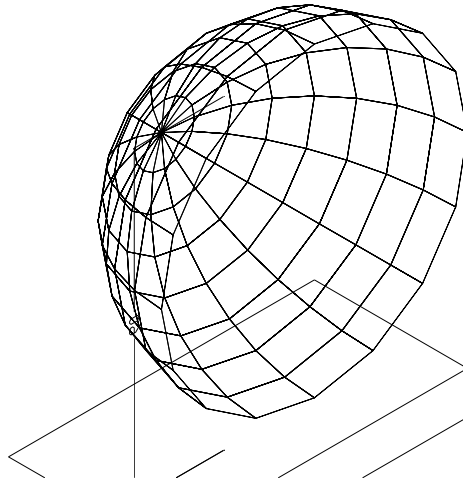

SOFIPLUS_Tutorial_IGH.docx

9.18.2 Load in gravity direction

Depth of the load is 70 m from the loading plane.

SOFISTIK: Create free areaload

Load value P1: [kN/m ²]	<input type="text" value="10.00"/>	Name of load:	<input type="text"/>
Load value P2: [kN/m ²]	<input type="text" value="10.00"/>	Loadcase:	<input type="text" value="1"/>
Load value P3: [kN/m ²]	<input type="text" value="10.00"/>	Loadtype: <input type="text" value="Load"/>	<input type="text" value="PG - Load in gravity dire"/>
Load value <input type="text" value="P4"/> [kN/m ²]	<input type="text" value="10.00"/>	Reference Type:	<input type="text" value="QGRP - Group Q"/>
<input checked="" type="checkbox"/> U.D.L.		Group- / reference number:	<input checked="" type="checkbox"/> all
<input type="checkbox"/> simplified Representation		Direction of projection:	<input type="text" value="ELEM - projected"/>
		Tolerance width:	<input type="text" value="70"/>

Use selected entities for new selectionset
 Apply automatically

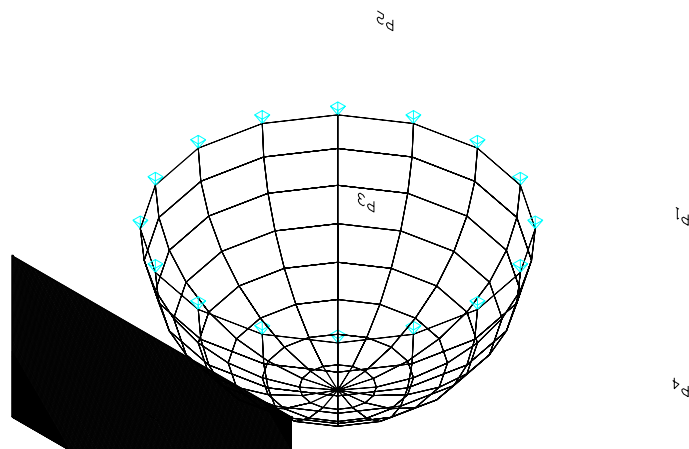

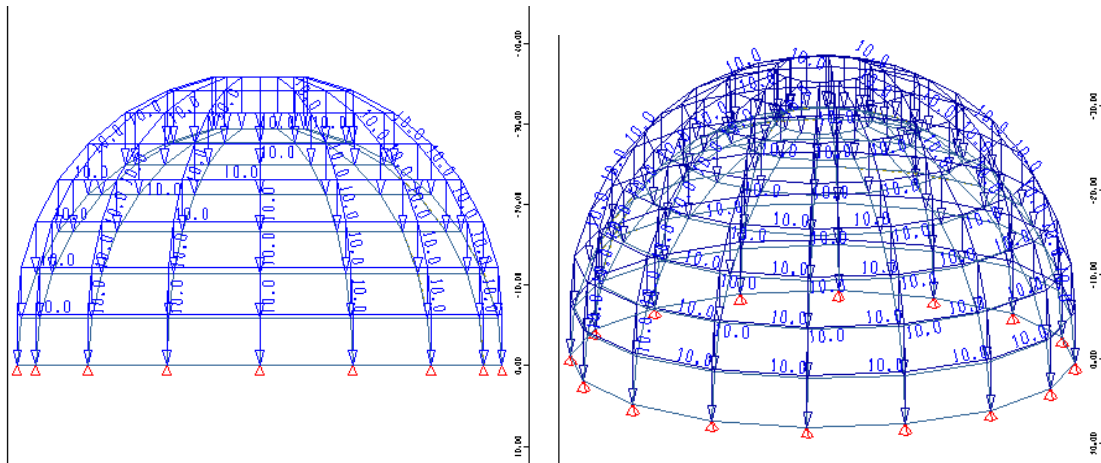

9.18.3 Load in global X-axis direction

Depth of the load is 70 m.

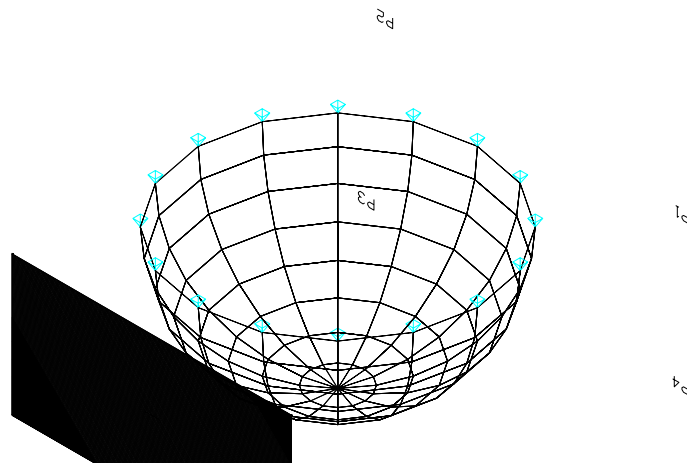

SOFISTIK: Create free areaload

Load value P1: [kN/m ²]	<input type="text" value="10.00"/>	Name of load:	<input type="text"/>
Load value P2: [kN/m ²]	<input type="text" value="10.00"/>	Loadcase:	<input type="text" value="2"/>
Load value P3: [kN/m ²]	<input type="text" value="10.00"/>	Loadtype: <input type="text" value="Load"/>	<input type="text" value="PXX - global load X"/>
Load value P4: [kN/m ²]	<input type="text" value="10.00"/>	Reference Type:	<input type="text" value="QGRP - Group Qi"/>
<input checked="" type="checkbox"/> <u>U</u> .D.L.		Group- / reference number:	<input checked="" type="checkbox"/> all
<input type="checkbox"/> simplified Representation		Direction of projection:	<input type="text" value="ELEM - projected"/>
		Tolerance width:	<input type="text" value="70"/>

Use selected entities for new selectionset
 Apply automatically

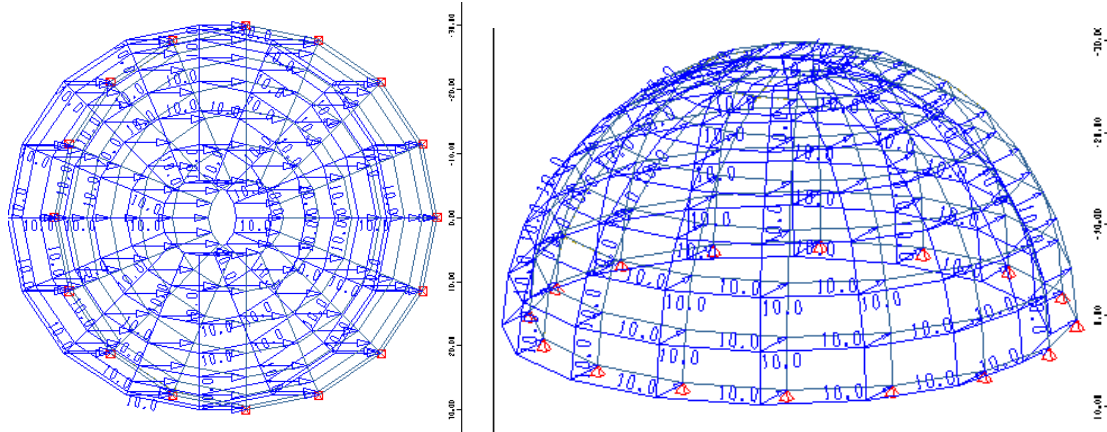

9.18.4 Trapezoidal load in global X-axis direction

Depth of the load is 40 m.

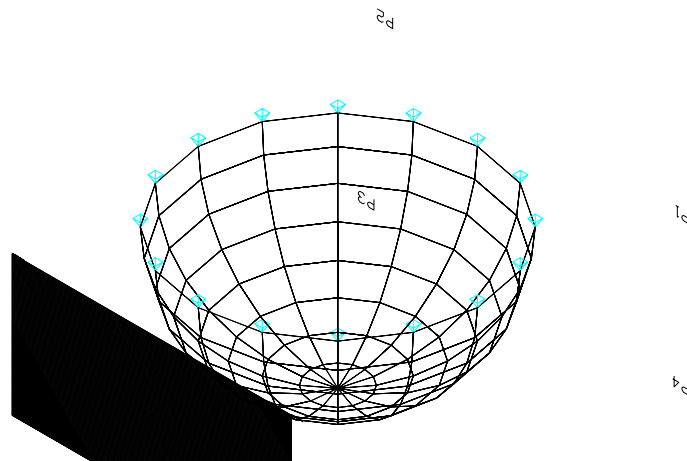

SOFiSTIK: Create free arealload				
Load value P1:	[kN/m ²]	<input type="text" value="20.00"/>	Name of load:	<input type="text"/>
Load value P2:	[kN/m ²]	<input type="text" value="20.00"/>	Loadcase:	<input type="text" value="3"/>
Load value P3:	[kN/m ²]	<input type="text" value="10.00"/>	Loadtype:	<input type="text" value="Load"/> P:XX - global load X
Load value P4:	[kN/m ²]	<input type="text" value="0"/>	Reference Type:	<input type="text" value="QGRP - Group Q"/>
<input type="checkbox"/> U.D.L.			Group- / reference number:	<input checked="" type="checkbox"/> all
<input type="checkbox"/> simplified Representation			Direction of projection:	<input type="text" value="XX - projected in"/>
			Tolerance width:	<input type="text" value="40"/>
<input type="checkbox"/> Use selected entities for new selectionset		<input type="checkbox"/> Apply automatically		

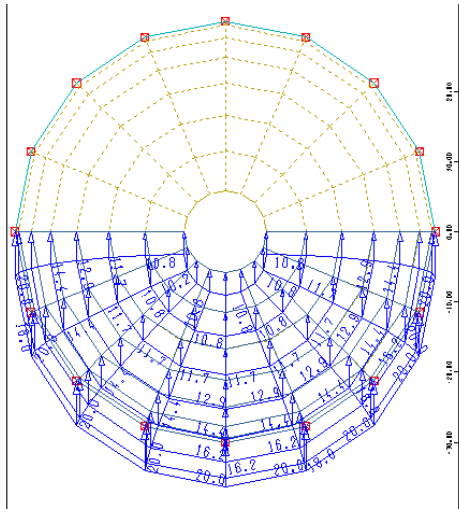

9.18.5 INCLINED LOADING PLANE

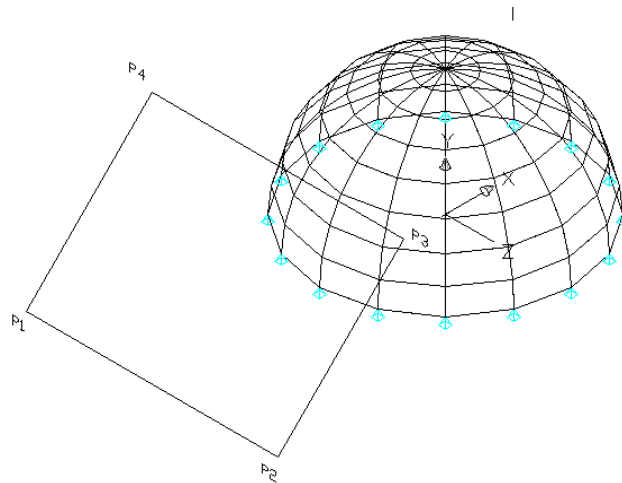

Load acts in local Z-axis direction (perpendicular to the plane)

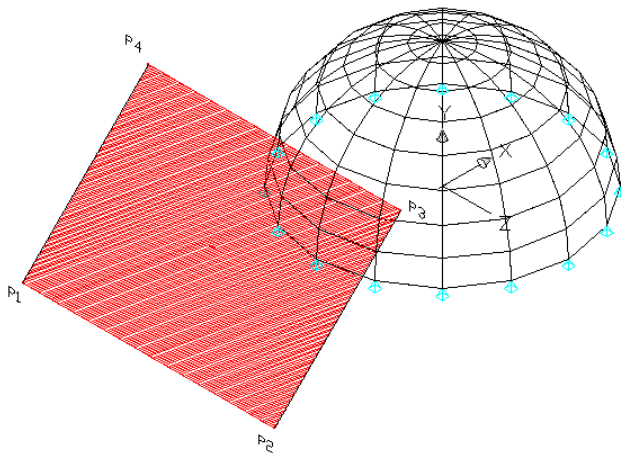

SOFiSTiK: Create free areaload

Load value P1: [kN/m²]	<input type="text" value="10.00"/>	Name of load:	<input type="text"/>
Load value P2: [kN/m²]	<input type="text" value="10.00"/>	Loadcase:	<input type="text" value="4"/>
Load value P3: [kN/m²]	<input type="text" value="10.00"/>	Loadtype:	<input type="text" value="Load"/> <input type="text" value="PZ - local load Z"/>
Load value P4: [kN/m²]	<input type="text" value="10.00"/>	Reference Type:	<input type="text" value="QGRP - Group Q"/>
<input type="checkbox"/> <u>simplified Representation</u>	<input checked="" type="checkbox"/> <u>U.D.L.</u>	Group- / reference number:	<input checked="" type="checkbox"/> all <input type="text"/>
		Direction of projection:	<input type="text" value="ELEM - projected"/>
		Tolerance width:	<input type="text" value="100"/>

Use selected entities for new selectionset
 Apply automatically

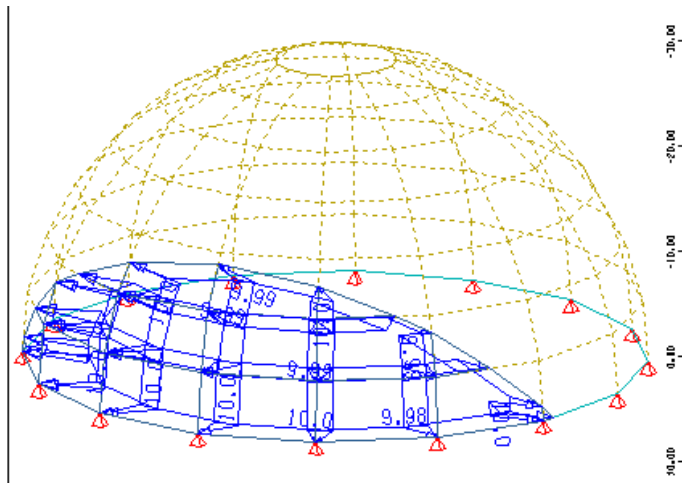

10. Example 5 : Load distribution on building

Load distribution on floors.

Load is applied on the upper floor.

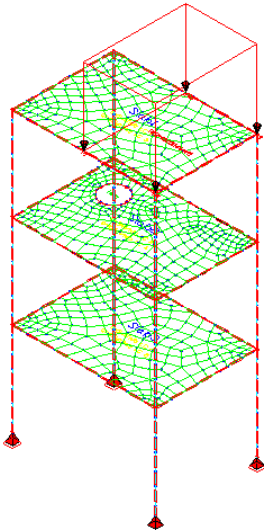

Load acts on 9.0 m depth (by presumption load has to be applied on all floors on 9.0 m depth from the surface where load is applied)

SOFiSTiK: Create free areaload

Load value P1: [kN/m ²]	<input type="text" value="10.00"/>	Name of load:	<input type="text"/>
Load value P2: [kN/m ²]	<input type="text" value="10.00"/>	Loadcase:	<input type="text" value="7"/>
Load value P3: [kN/m ²]	<input type="text" value="10.00"/>	Loadtype	<input type="text" value="Load"/> <input type="text" value="PZZ - global load Z"/>
Load value P4: [kN/m ²]	<input type="text" value="10.00"/>	Reference Type	<input type="text" value="QGRP - Group Q1"/>
<input type="checkbox"/> simplified Representation	<input checked="" type="checkbox"/> <u>D.L.</u>	Group- / reference number	<input checked="" type="checkbox"/> all <input type="text"/>
<input type="checkbox"/> Use selected entities for new selectionset		Direction of projection:	<input type="text" value="ELEM - projected"/>
<input type="checkbox"/> Apply automatically		Tolerance width	<input type="text" value="10"/>

Load distribution across floors.

